

WHY EWELLIX

High performance actuators – CASM

Precise motion control

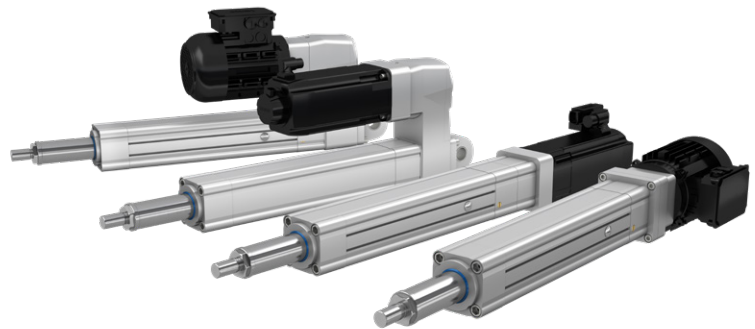

CASM electric cylinders are ideally suited to perform fast and powerful linear movements. Ewellix offers a wide range of high performance electromechanical linear actuators, in a variety of designs and setups for both general and specific industrial applications. They range from high load capacities and fast operating speeds to systems designed for continuous operation with zero to low maintenance.

Unlike pneumatic or hydraulic cylinders, electric cylinders are flexible, speed can be dynamically set, and can be positioned precisely. In addition, due to a reduced number of components, the whole system is more compact, more cost effective, resulting in lower energy and maintenance costs.

The CASM modular concept enables easy connection to your preferred motor and control system. This can reduce design and programming costs considerably. Thanks to high grade materials, a sealing system with IP54S or IP65S level protection and high-quality manufacturing, CASM electric cylinders can also be used long term even under harsh conditions.

Linear actuators convert electricity into linear motion. Ewellix electromechanical actuators replace hydraulic or pneumatic cylinders with a ball or roller screw mechanism powered by an electric motor and offer great benefits.

To meet any space and performance requirements, we provide inline and parallel gearboxes as well as AC and servomotors.

Common applications

- Blow moulding
- Servo press
- Filling stations
- Excavator
- Aerial work platforms
- Amusement and simulators

General features



Modular concept for customized solutions

Within each module, the customer can select the components inside to build a customized solution.



Precision and repeatability

Accurate positioning based on motor feedback system. The low backlash design provides positioning precision of up to $\pm 0,01$ mm.



Customized motor adapter plate

All motors are equipped with specific adapters to keep the same mechanical interface, independent of the selected motor type.



Smaller footprint

With Ewellix Spure gearbox customers are able to do downsize to a smaller motor to save cost, reduce weight, and have a failsafe solution that locks itself in case of failure.



Easy to integrate

The high level of flexibility with variance of body assembly allows for easy integration or early replacement for hydraulic cylinders. CASM-32/40/63 are based on pneumatic ISO 15552 standard enabling drop-in replacement.

Ewellix range overview CASM

CASM-25



- Very small and light
- Highly energy efficient
- Multi-option modular system
- Easy integration and fast assembly
- Space saving solution
- Highest levels of precision and repeatability

- Max dynamic axial force: 0,3 kN
- Max linear speed: 125 mm/s
- Max stroke: 50 mm
- Duty cycle: 100 %
- Motor type: servo motor
- IP 54S

CASM-32



- Low force
- High speed
- 3 different screw options
- Complies with pneumatic ISO 15552
- Inline 1:1 or parallel 1:1

- Max dynamic axial force: 0,7 kN
- Max linear speed: 500 mm/s
- Max stroke: 400 mm
- Duty cycle: 100 %
- Motor type: servo or BLDC
- IP 54S

CASM-40



- Low to medium force
- Very high speed
- 3 different screw options
- Complies with pneumatic ISO 15552
- Inline 1:1 or parallel 1:1

- Max dynamic axial force: 2,4 kN
- Max linear speed: 826 mm/s
- Max stroke: 600 mm
- Duty cycle: 100 %
- Motor type: servo or BLDC
- IP 54S

CASM-63

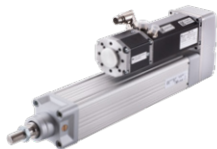

- Medium force
- Very high speed
- 3 different screw options
- Complies with pneumatic ISO 15552
- Inline 1:1 or parallel 1:1

- Max dynamic axial force: 5,4 kN
- Max linear speed: 1067 mm/s
- Max stroke: 800 mm
- Duty cycle: 100 %
- Motor type: servo or BLDC
- IP 54S

CASM-100



- High force
- Very high speed
- 4 different screw options, ball or roller screw
- Gearbox options: Inline 1:1, parallel belt (1:1 or 2:1), parallel spure (4:1, 10:1, 25:1)
- Centrifugal brake option
- Manual override

- Max dynamic axial force: 82 kN
- Max linear speed: 890 mm/s
- Max stroke: 2000 mm
- Duty cycle: 100 %
- Motor type: servo or AC motor
- IP54S or IP65

Application examples

Servo press

Electromechanical servo presses are used for a wide variety of applications including press fitting, stamping or clinching. Larger presses can be used for high precision deep drawing. Ewellix roller screw technology is the best solution to handle the high peak load of those applications and offer the best in class life time, power density and reliability.

Functions

- Pressing
- Bending
- Cutting
- Press fitting of parts



Benefits

- Outstanding force repeatability for constant quality
- Easier force and position control
- Longer service life
- Increased productivity
- Lower maintenance cost

Blow moulding

Plastic blow moulding faces ever increasing challenges for the production of more sustainable plastic containers. Machine makers need to implement the best energy efficiency and process control techniques.

Functions

- Blow pin
- Calibration clamping
- Extruded bobbing
- Injection
- Clamping

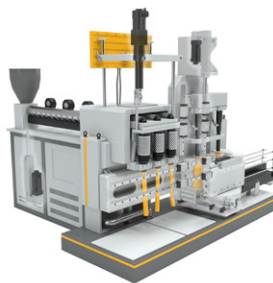

Benefits

- Oil free for food and beverage applications
- High accurately and precise positioning
- High speed and acceleration
- Long service life
- Modular and high flexibility
- Higher efficiency
- Peak load acceptance
- High duty
- Wide range available from 5 to 30 tons

Simulators and amusement

Simulators are used to imitate movement behaviour under realistic conditions, be it for scientific, training or entertainment purposes. With the help of multi-axis systems almost all movement patterns can be imitated with high accuracy and reactivity

Functions

- 6 degrees of movement (roll, pitch, yaw, heave, surge, sway)



Benefits

- Low noise
- High motion accuracy and repeatability
- Compactness
- Full flexible motor selection
- Complete range, platform for a few kg to platforms for +6000 kg with 2 m stroke and speed of 1,7 m/s

Filling stations

Automated flexible filling stations are used when food and beverage liquid has to be brought into bottles and cans. High acceleration and speed, a long lifetime and easy setup and controllability are key for this application.

Functions

- Functions
- Dosing
- Filling
- Labelling



Benefits

- No oil and no risk for oil leaks
- Higher productivity and shorter return on investment
- Maintenance free
- Flexibility for multiple setting
- Efficient for less power consumption
- Lower CO₂ footprint

Ewellix CASM actuators: how are they different?

Safe and reliable operation in critical applications

- Failsafe gear reduction for motor downsizing, Spure gearbox
- Speed limiting centrifugal brake option
- Manual override
- Made for outdoor environment up to IP65 and with corrosion protection and certification

Large screw and gearbox selection

- Roller screw option available
- At least 3 different screw options available for each size with different screw types and screw leads
- Inline and parallel motor mounting option
- CASM-100 gearbox available in 1:1, 2:1, 4:1, 10:1 and 25:1 gear ratio

Easy integration and adoption

- Easy to get started with quick start e-MOVEKIT and when move to system integration e-MOVEKIT for serial production
- Drop-in replacement with pneumatic ISO 15552 standard
- Modular platform allowing quick and easy integration
- Fits any motor: Stepper, DC, BLDC, AC, Servo

Actuator select

This simple tool helps you quickly navigate through the wide range of Ewellix actuators to select the right one for your specific needs.

Actuator select includes the latest actuators, lifting columns and control units on offer along with a complete list their functions. Choose the desired product family and then, by entering a few simple parameters, you will be guided in the selection. The results will be automatically updated after each input entry.

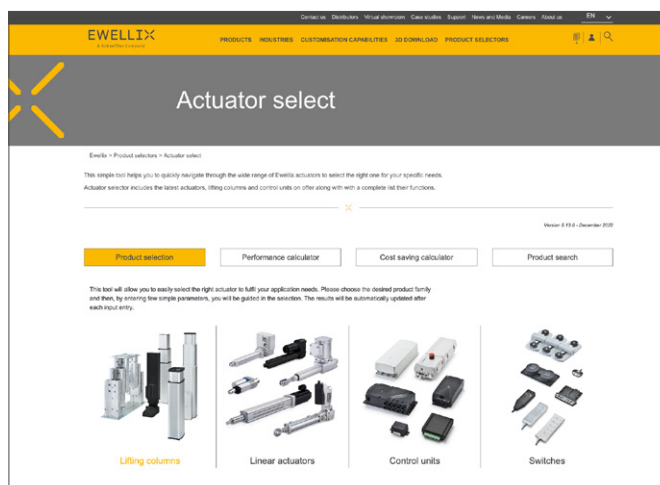

For more detailed information see our High performance actuator catalogue.

ewellix.com

© Ewellix
 All contents of this publication are the property of Ewellix, and may not be reproduced or given to third parties (even extracts) without permission. Although great care has been taken in the production of this catalog, Ewellix does not take any responsibility for damage or other loss resulting from omissions or typographical errors. The photo may differ slightly in appearance from the actual product. Due to continuous improvements being made in our products, the product's appearance and specifications are subject to change without notice.