

# TLC - Dimensional drawing

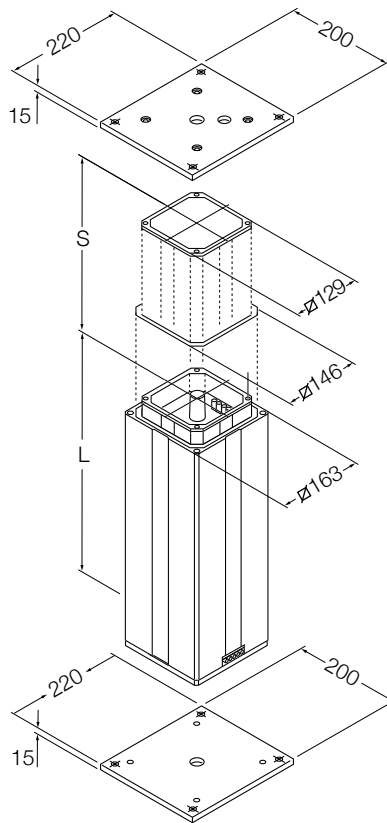
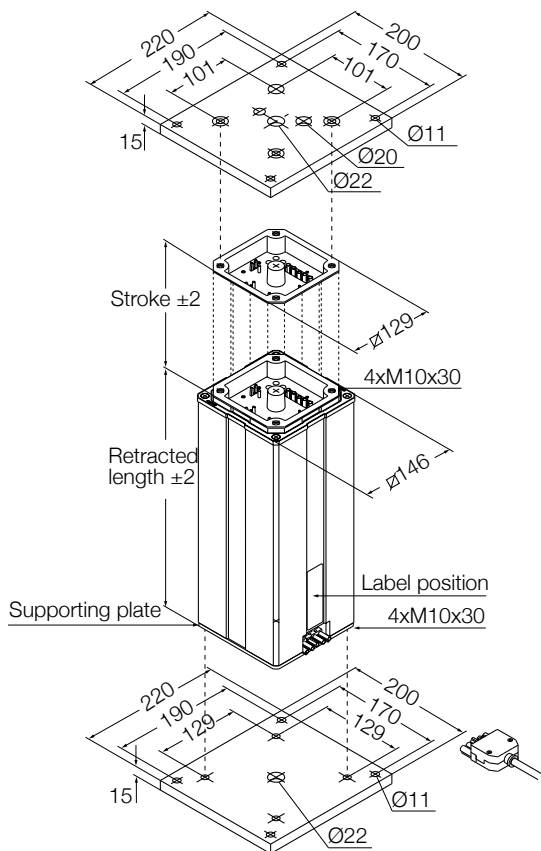

**Note:** mounting plates  
 are not included.  
 To be ordered separately.

## Legend:

S = stroke

L = retracted length