

CASM-63 BF inline - Dimensional drawing

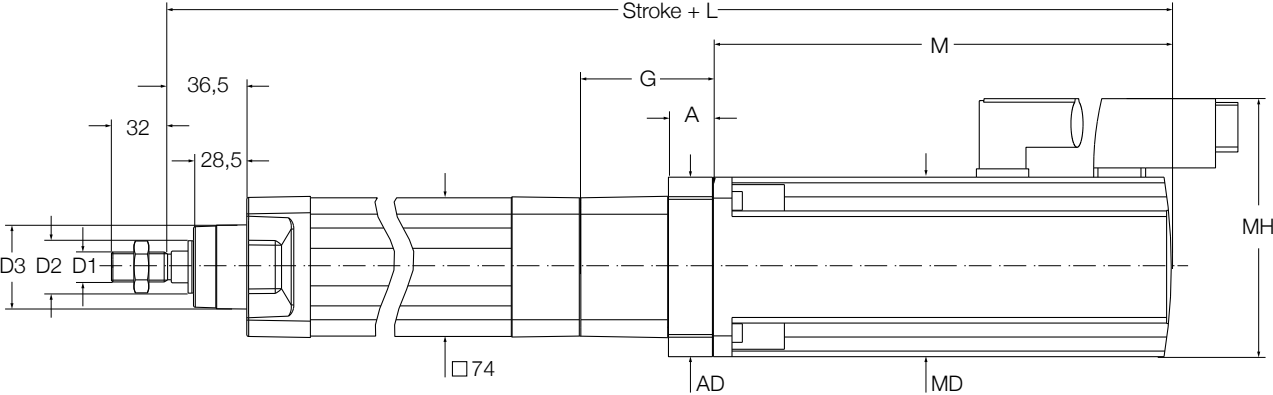

Motor	D1	D2	D3	L	G	A	AD	M	MD	MH
		mm								
BG75	M16 × 1,5	Ø28	Ø45	515,1	67,1	20	75	234	75	100
1FK7034	M16 × 1,5	Ø28	Ø45	476,4	62,4	15	75	200	72	117
1FK7044	M16 × 1,5	Ø28	Ø45	529,9	70,9	23,5	96	245	96	138

CASM-63 BF parallel - Dimensional drawing

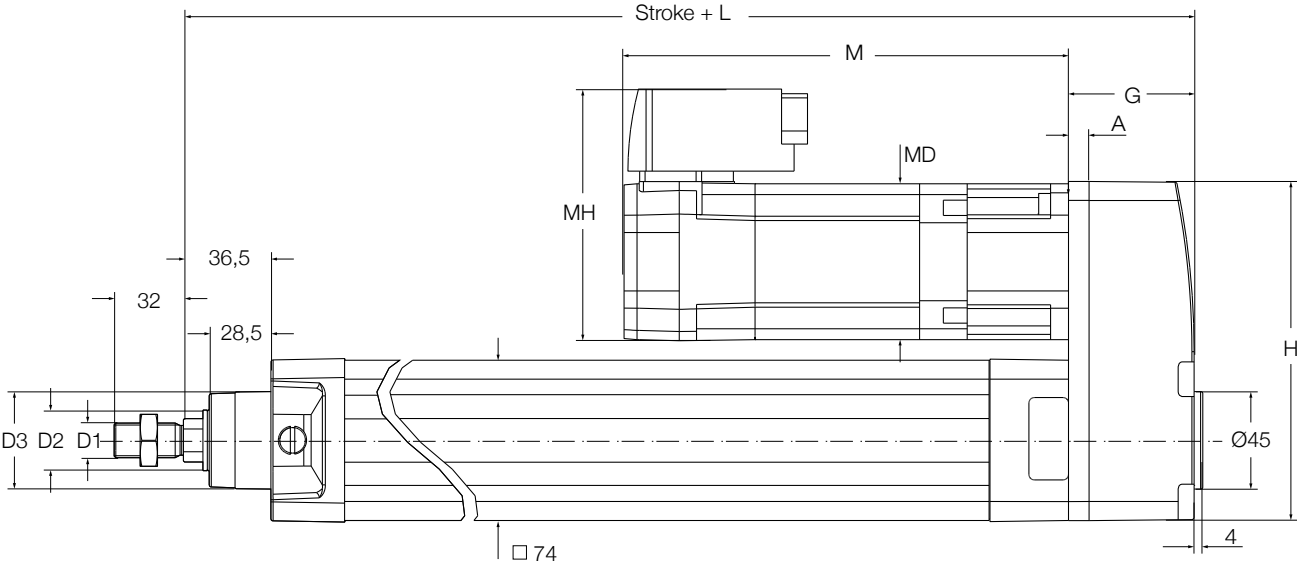

Motor	D1	D2	D3	L	G	A	H	M	MD	MH
		mm								
BG75	M16 × 1,5	Ø28	Ø45	281,1	39,5	9	157,3	234	75	100
1FK7034	M16 × 1,5	Ø28	Ø45	272,1	58,1	9	157,3	200	72	117