

CASM-40 BN inline - Dimensional drawing

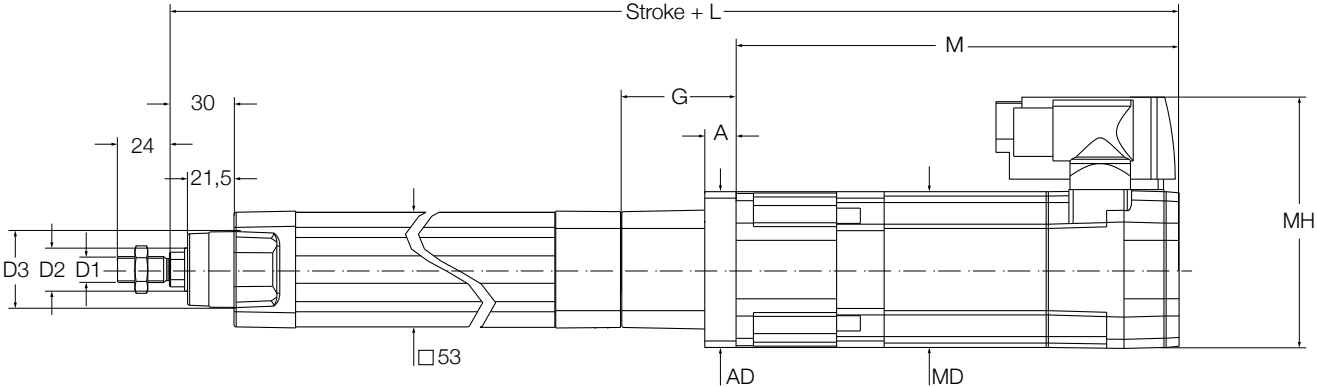

Motor	D1	D2 mm	D3	L	G	A	AD	M	MD	MH
BG65S	M12 × 1,25	Ø20	Ø35	431	53,5	35	54	201	65	96,5
BG75	M12 × 1,25	Ø20	Ø35	462,9	52,4	14	75	234	75	100
1FK7022	M12 × 1,25	Ø20	Ø35	400,9	49,4	11	64	175	55	103
1FK7034	M12 × 1,25	Ø20	Ø35	428,9	52,4	14	72	200	72	117

CASM-40 BN parallel - Dimensional drawing

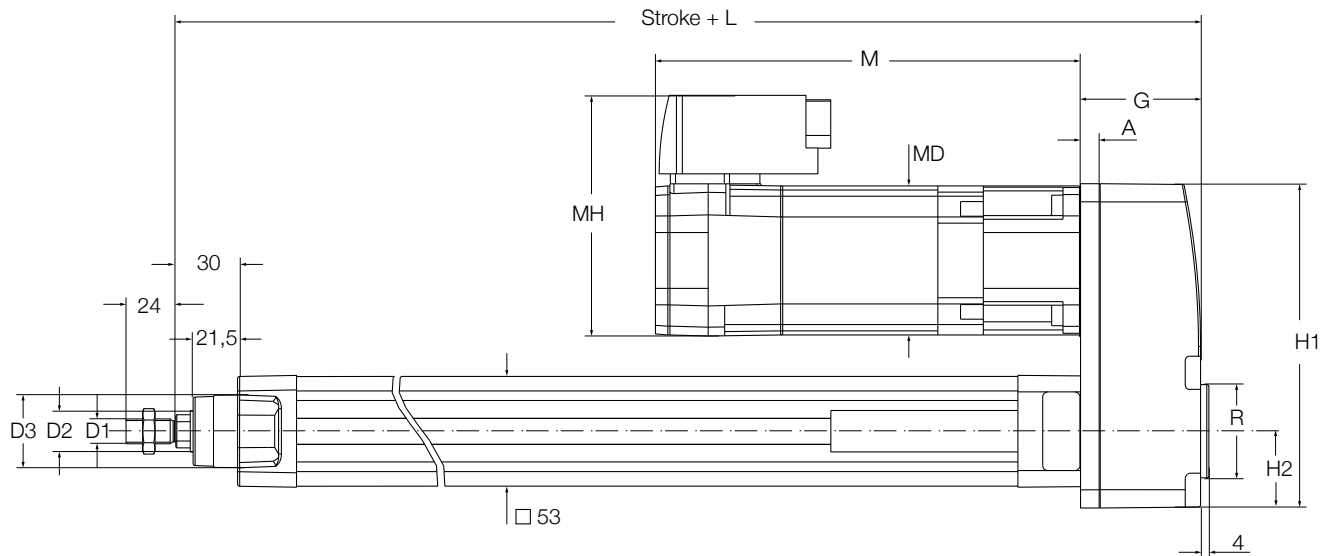

Motor	D1	D2	D3	L	G	A	H1	H2	M	MD	MH	R
BG65S	M12 × 1,25	Ø20	Ø35	223	46,5	7	115,3	26,8	201	65	96,5	Ø35
BG75	M12 × 1,25	Ø20	Ø35	234,5	58	7	156,6	37,05	234	75	100	Ø45
1FK7022	M12 × 1,25	Ø20	Ø35	223,6	47,1	7	115,3	26,8	175	55	103	Ø35
1FK7034	M12 × 1,25	Ø20	Ø35	234,6	58,1	9	157,3	37,05	200	72	117	Ø45