

CASM-32 BN inline - Dimensional drawing

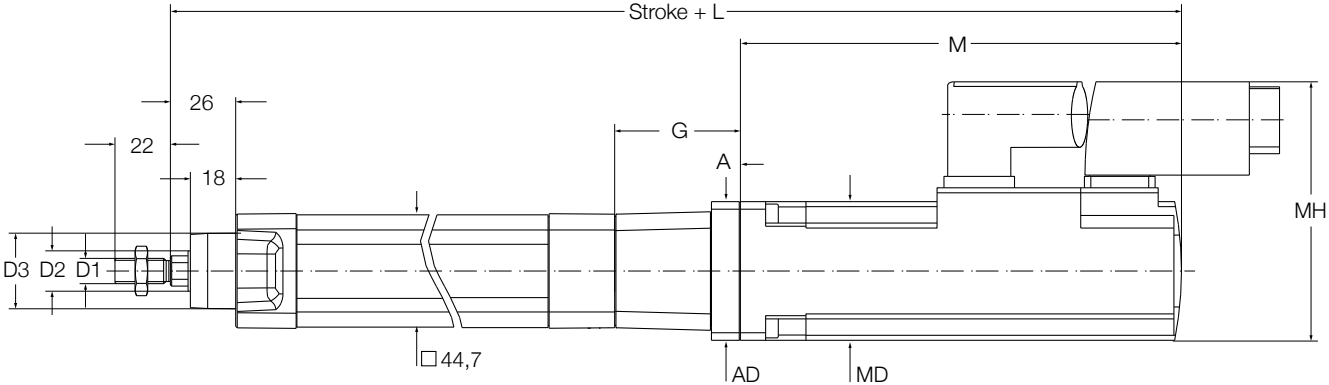

Motor	D1	D2	D3	L	G	A	AD	M	MD	MH
		mm								
BG45	M10 × 1,25	Ø16	Ø30	347,7	39,7	6,7	45,5	160	44	60,8
1FK7015	M10 × 1,25	Ø16	Ø30	353,9	40,9	9	40	165	40	86
1FK7022	M10 × 1,25	Ø16	Ø30	372,4	49,4	11	55	175	55	103

CASM-32 BN parallel - Dimensional drawing

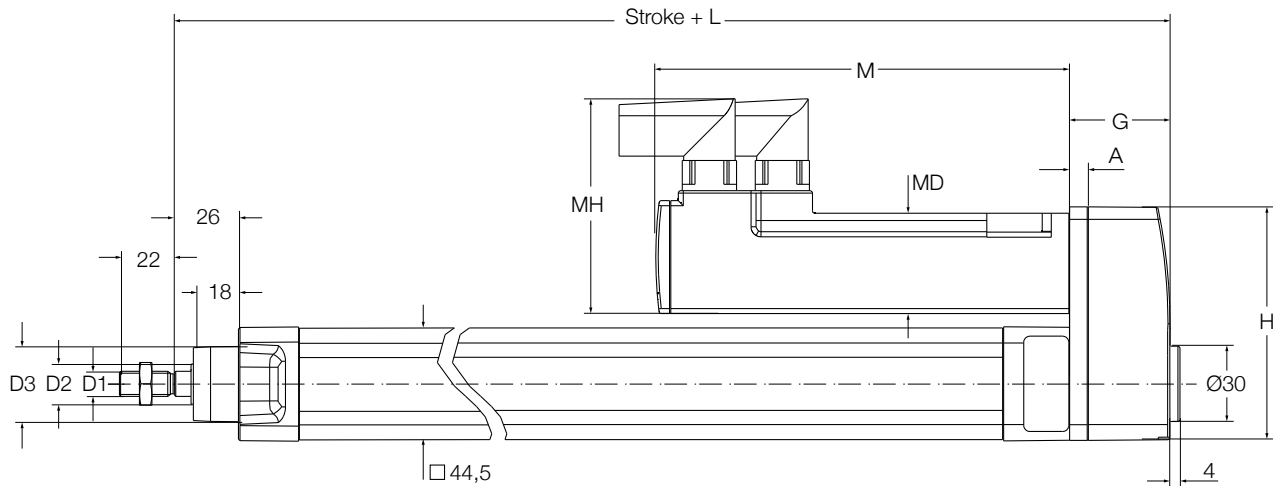

Motor	D1	D2 mm	D3	L	G	A	H	M	MD	MH
BG45	M10 × 1,25	Ø16	Ø30	187,5	39,5	7	93,3	160	44	60,8
1FK7015	M10 × 1,25	Ø16	Ø30	188,1	40,1	7	93,3	165	40	86