

CASM-32 linear unit - Dimensional drawing

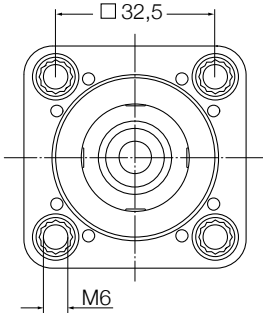
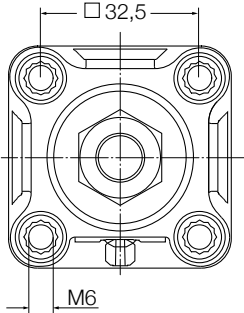
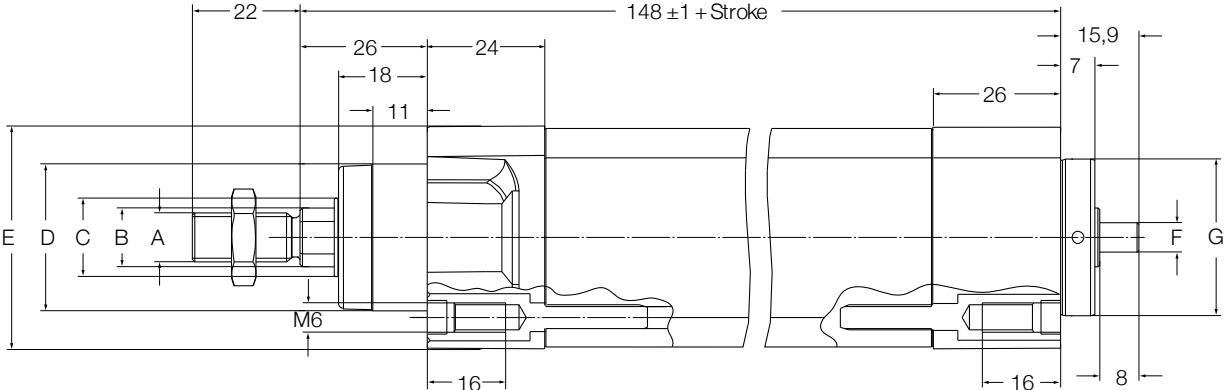

A	B	C	D	E	F	G
---	---	---	---	---	---	---

mm

CASM-32	M10 × 1,25	Ø12	Ø16	Ø30d11	□ 45,7	Ø6h6	Ø32 ^{-0.05} / _{-0.07}
---------	------------	-----	-----	--------	--------	------	---