

**EWELLIX**

A Schaeffler Company



# Vertical axis for Techman collaborative robots LIFTKIT-TM



# The heritage of innovation

Ewellix is a global innovator and manufacturer of linear motion and actuation solutions. Our state-of-the-art linear solutions are designed to increase machine performance, maximise uptime, reduce maintenance, improve safety and save energy. We engineer solutions for assembly automation, medical equipment, mobile machinery, distribution and a wide range of other industrial applications.

## Technology leadership

We earned our reputation through decades of engineering excellence. Our journey began over 50 years ago as part of the SKF Group, a leading global technology provider. Our history provided us with the expertise to continuously develop new technologies and use them to create cutting edge products that offer our customers a competitive advantage.

In 2019, we became independent and changed our name to Ewellix. We are proud of our heritage. This gives us a unique foundation on which to build an agile business with engineering excellence and innovation as our core strengths.

## Global presence and local support

With our global presence, we are uniquely positioned to deliver standard components and custom-engineered solutions, with full technical and applications support around the world. Our skilled engineers provide total life-cycle support, helping to optimise the design, operation and maintenance of equipment thus improving productivity and reliability while reducing costs. At Ewellix, we don't just provide products; we engineer integrated solutions that help customers realise their ambitions.

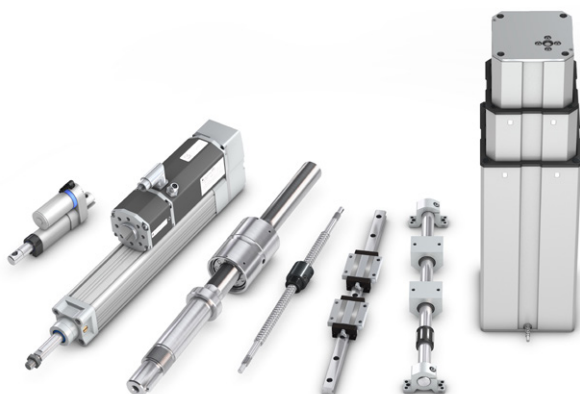

## Schaeffler Group – We pioneer motion

Ewellix is since 2023 owned by the Schaeffler Group.

As a leading global supplier to the automotive and industrial sectors, the Schaeffler Group has been driving forward groundbreaking inventions and developments in the fields of motion and mobility for over 75 years.

With innovative technologies, products, and services for electric mobility, CO<sub>2</sub>-efficient drives, Industry 4.0, digitalization, and renewable energies, the company is a reliable partner for making motion and mobility more efficient, intelligent, and sustainable.

Schaeffler manufactures high-precision components and systems for powertrain and chassis applications as well as rolling and plain bearing solutions for a large number of industrial applications.



# Benefits for handling and inspection

Ewellix provides effective solutions to complete vertical adjustment in a smart way with a wide range of “ready to mount” additional linear axis solutions. We designed them for different applications, giving to your robot an extended operation range.

Fully automated pick and place solutions are becoming a new standard with packaging stations.

A standard collaborative robot does not have such a large vertical working range. With the Ewellix LIFTKIT the base of the robot can be lifted or lowered to work at optimal position.

Stacking on pallets starts at floor level, but the stack can be up to 2 m high, and that's where LIFTKIT can increase your packaging station efficiency.

And every time you need a repetitive operation, as end of line quality inspection, our LIFTKIT can guarantee precision and reliability to maximize your results.

Here below an application example in automotive assembly lines, with a custom LIFTKIT vertical axis for ceiling mounting installation.



# Linear axis for collaborative robots LIFTKIT-TM

## Operating range extension

- Vertical lifting of the cobot by up to 1 400 mm (longer on request) with compact retracted height
- Robust column design for industrial use, vibration free motion and virtually maintenance free

## Plug-and-play solution

- Hardware interface compatible with TM5, TM12, TM14 and TM20 robots
- Techman certified product
- Software control integrated with TMflow for easy motion programming

## Cost savings and higher productivity

Cobots combined with Ewellix LIFTKIT provide a cost-effective solution to upgrade an existing assembly shop, moving from a manual handled to a fully automatized line.



## Technical data

	Unit	LIFTKIT-TM-601
<b>Column type</b>	-	TLT
<b>Performance Data</b>		
Max. push load	N	1 500
Max. pull load	N	0
Max. dynamic moment	Nm	210
Max. static moment	Nm	3 000
Max. linear speed	mm/s	80
Duty cycle	-	10% (20% at 500N)
<b>Mechanical Data</b>		
Screw type	-	Acme screw
Stroke range	mm	500 - 1 400
Retracted length (software controlled)	mm	Stroke/2 + 275
Weight @ 0 mm stroke	kg	21
Δ weight per 500 mm stroke	kg	1,7
Robots compatibility	-	TM5, TM12, TM14, TM20
Cable management	-	Threads on column and interface plate to attach cable management
<b>Electrical</b>		
Input Voltage/Current	-	120 VAC / 6,5 A 230 VAC / 3,3 A
Input frequency	Hz	50-60
Input Fuse	A	10
I/O voltage	-	24 VDC
I/O current	-	max. 10 A not protected
Emergency stop	-	STO up to PLe, Cat.4
<b>Communication</b>		
Control interface	-	Compatible with TMflow on TM HW 3.2 or higher
Positioning, repeatability	mm	± 1
Accessible positions	-	any
Feedback	-	Position & Status
Soft start and stop	-	Implemented for smooth operation
Software control	-	TMflow software
<b>Environment</b>		
Type of protection	-	IP40
Ambient temperature	°C	+10 to +40
Max. humidity	%	85
Vibration	-	Stationary industrial environment

## Dimensional drawing

### TLT Lifting column

#### Robot attachment plate

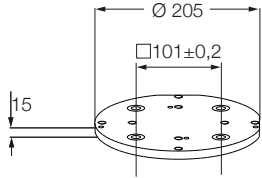

#### TLT Column

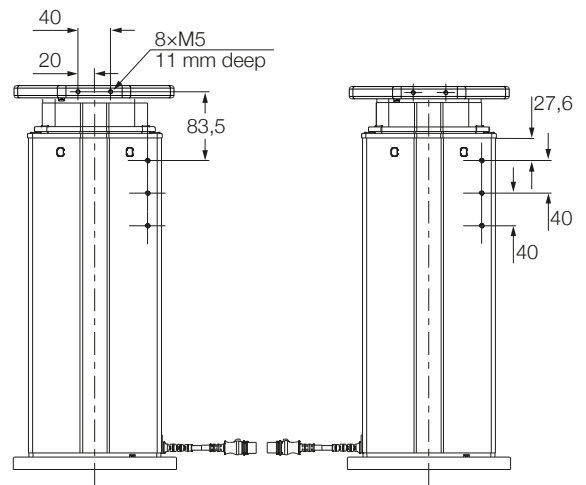
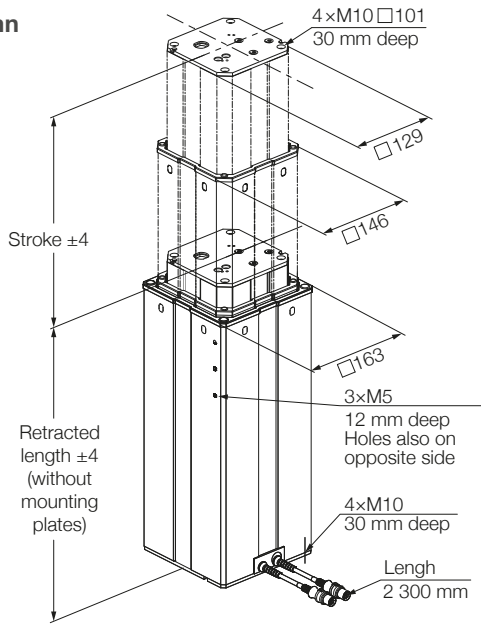

#### Bottom fixation plate

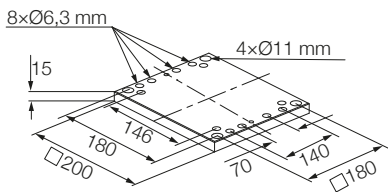

#### Controller

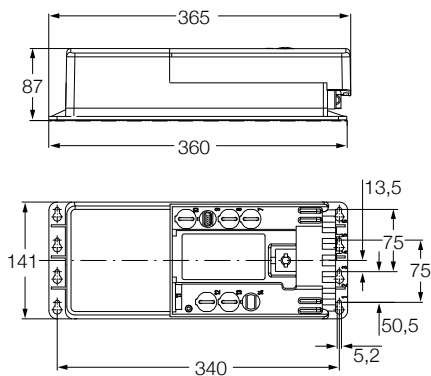

#### SBOX

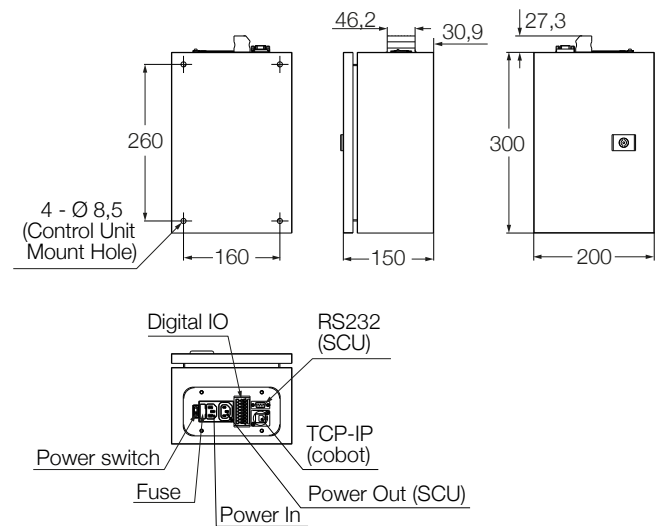

**Cable management**

Threads for cable management attachments

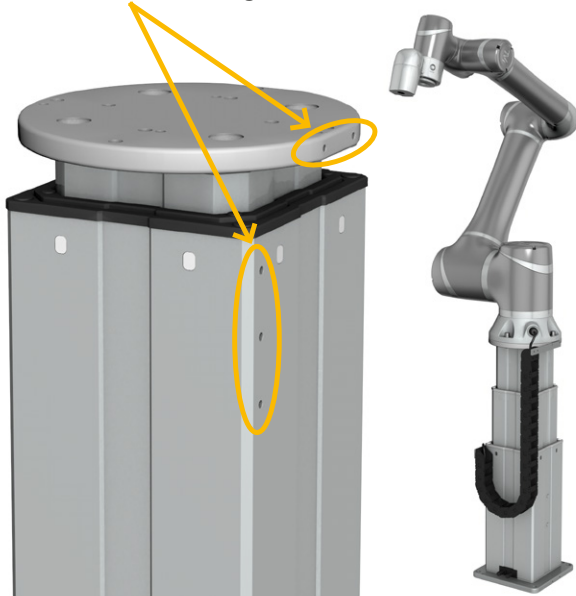

**Connection diagram**

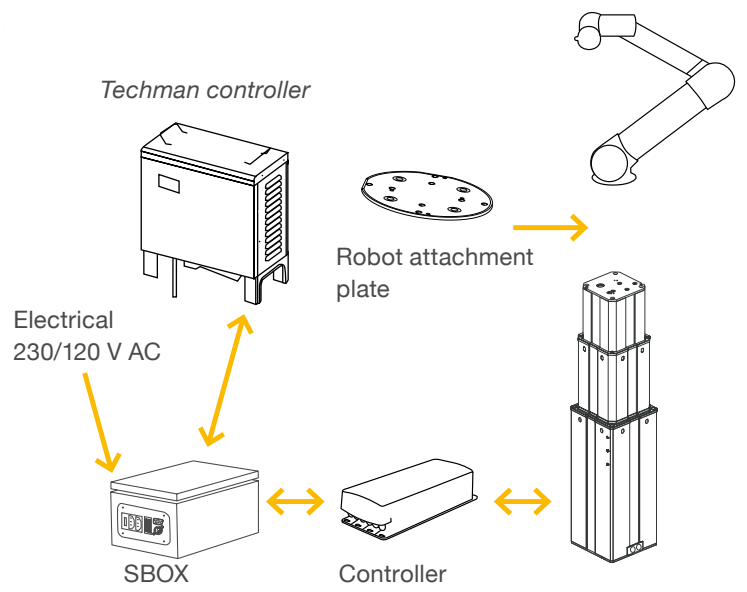

**LIFTKIT contains**



Quick start guide



Controller



SBOX

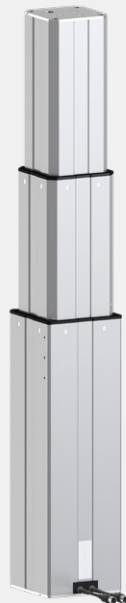

Lifting column



Robot attachment plate



Bottom fixation plate



Handswitch



SBOX Key



SBOX I/O cable



SBOX power cable



SBOX to controller power cable



Controller I/O cable



RS232 cable



Ethernet cable

## Software functionality

The Ewellix LIFTKIT component allows customers to integrate the LIFTKIT lifting column's capabilities with TMflow applications.

### Setup & Programming:

The Ewellix LIFTKIT command component allows the set up and control the LIFTKIT in TMflow. The component can be inserted multiple times throughout a TMflow project via drag-and-drop to access multiple positions while getting feedback about current position and status.

### Safety elements

The LIFTKIT has a range of safety elements built in to allow its integration into a robot application, including safety relay certified according to ISO 13849-1, allowing STO up to PLe, Cat. 4

### Software updates

To download the latest software update please check on [ewellix.com/support/media-library](http://ewellix.com/support/media-library) -> [Software updates](#) -> [LIFTKIT](#).

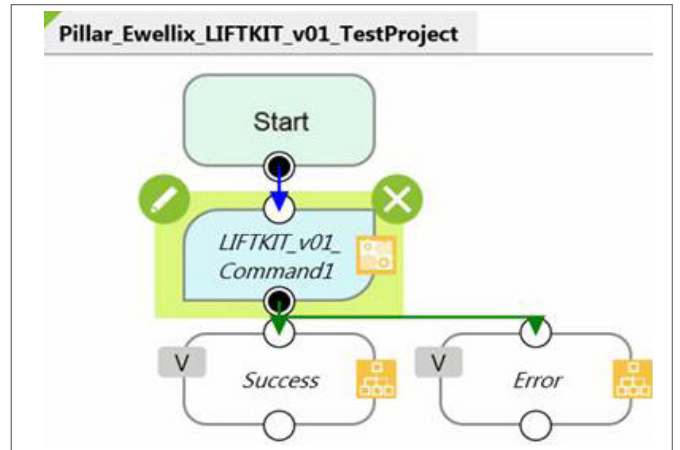

The image shows the configuration interface for the 'Pillar\_Ewellix\_LIFTKIT\_v01\_Command' component. The provider is 'Omron'. The node name is 'LIFTKIT\_v01\_Command1'. The interface includes several configuration options with right-pointing arrows: 'Set\_IP', 'Get\_Info', 'Set\_Info', 'Move\_Absolute', and 'Advanced\_Settings'.

LIFTKIT software functionality

## Ordering key

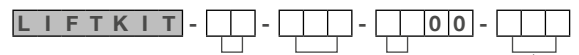

**Robot**  
TM Techman

Stroke	Stroke	Retracted length	Extended length
500	500 mm	525 mm	1 025 mm
600	600 mm	575 mm	1 175 mm
700	700 mm	625 mm	1 325 mm
800	800 mm	675 mm	1 475 mm
900	900 mm	725 mm	1 625 mm
A00	1 000 mm	775 mm	1 775 mm
B00	1 100 mm	825 mm	1 925 mm
C00	1 200 mm	875 mm	2 075 mm
D00	1 300 mm	925 mm	2 225 mm
E00	1 400 mm	975 mm	2 375 mm

**Electrical options**

11	120 V AC / US cable
22	230 V AC / EU cable
23	230 V AC / CN cable
24	230 V AC / UK cable
25	230 V AC / CH cable

**Column type**  
601 TLT



**ewellix.com**

© Ewellix

All contents of this publication are the property of Ewellix, and may not be reproduced or given to third parties (even extracts) without permission. Although great care has been taken in the production of this catalog, Ewellix does not take any responsibility for damage or other loss resulting from omissions or typographical errors. The photo may differ slightly in appearance from the actual product. Due to continuous improvements being made in our products, the product's appearance and specifications are subject to change without notice.

**PUB NUM IL-07032/4-EN-March 2023**

Schaeffler and Schaeffler logo are trademarks of the Schaeffler Group.  
Techman and Techman logo are trademarks of the Techman Corporation