

EWELLIX

MAKERS IN MOTION

SERIES SP

Ewellix precision ball screws

High-precision and low-noise ball screws for machine tool,
automation and high duty applications



Ewellix high performance precision ball screws – SP Series

Made
in the USA

High precision and low noise ball screws for machine tool, automation and high duty applications

Today's automated equipment manufacturers need components and systems that offer high reliability, precision and repeatability with low noise. The new Ewellix high performance precision ball screws do this while giving manufacturers a wide range of design flexibility. Enabling precise positioning for demanding applications, these quiet-running ball screws operate at high speeds with low friction and minimal service requirements. Robust and capable of handling high thrust loads, the screws are supplied in a standard range of nut types and available as customized solutions to meet any application requirement.

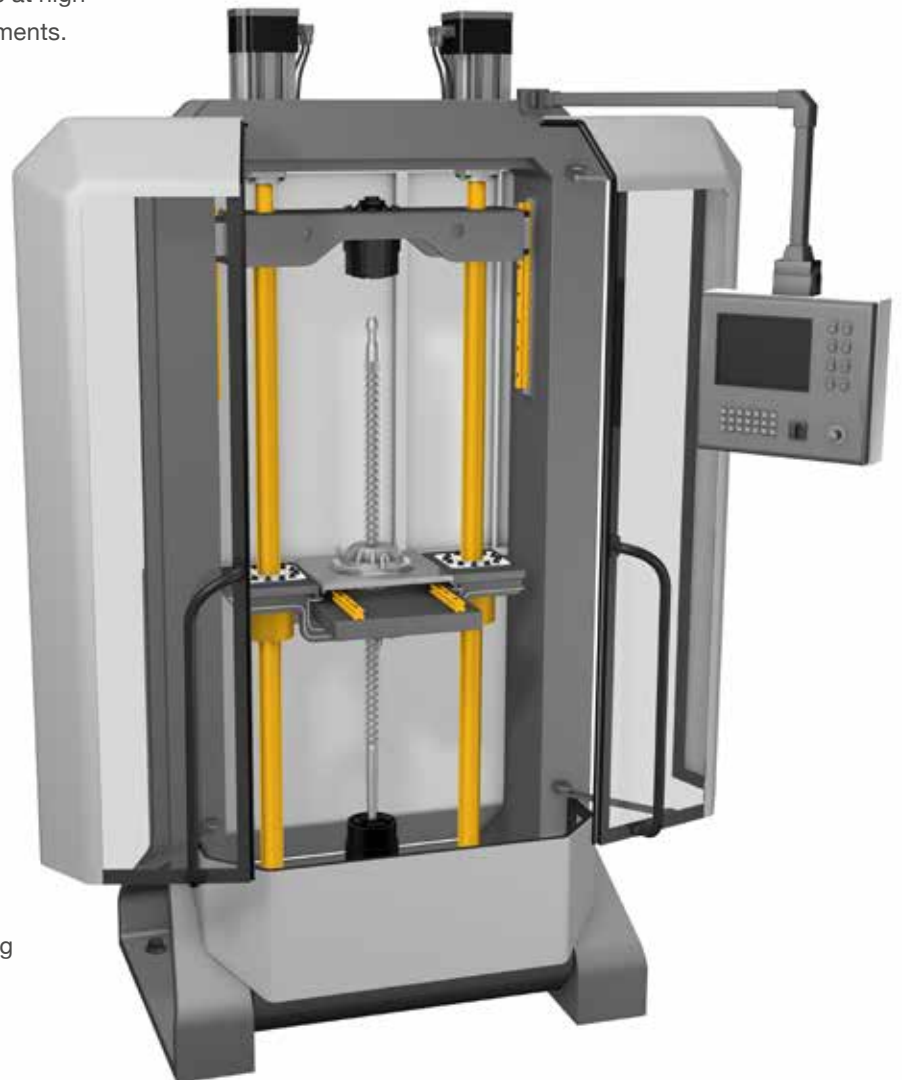

Broaching
machine

Optimized design features for your application

Ewellix high performance precision ball screws open up new design and performance options for equipment manufacturers. Designers can extend machine reliability, increase speed and output, and reduce noise for a wide range of applications.

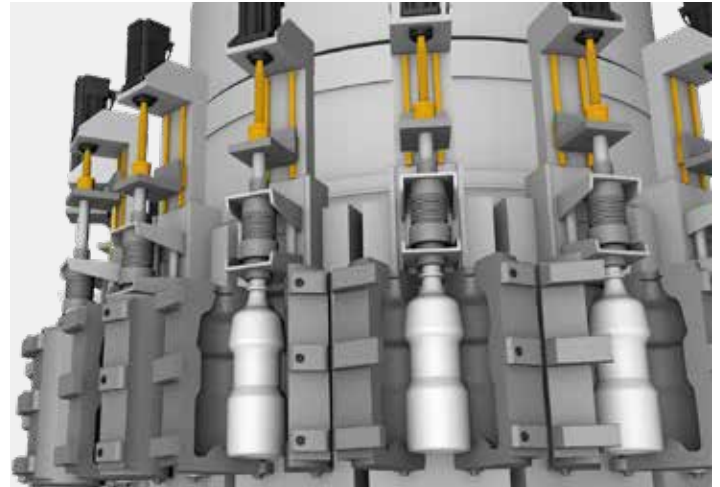

Improved nut design

Balls are picked up smoothly for a new highly optimized ball recirculation path resulting in optimal performance.

- Reduces tangential efforts on the recirculating balls
- Enables up to 25% higher speed limits ($n_{do} < 100,000$)
- Reduces noise levels
- Enables smoother running
- Provides much longer service life
- High positioning accuracy

External interface

The SP Series assortment offers easy mounting with:

SP – cylindrical design

- Machined outside diameter
- Includes machined key

SPF – integral flange design

- Machined outside diameter and flange face
- Six bolt holes for mounting

SPT – universal, threaded-nose design

- Interchangeable with most existing standard solutions
- Same attachment as existing SX series

Typical applications

- Gantry milling machine
- Precision grinding machine
- Honing machine
- Servo presses
- Oil and gas
- Material handling

Lead precision

Manufacturing precision

Generally speaking, the precision indicated defines the lead precision that complies with ISO standards, e.g. G3, G5, etc. (↳ **table 1**).

Parameters other than lead precision correspond in standard to class 5 of ISO 3408–3:2006. If the application requires special tolerances, ISO class 3 or ISO class 1, please specify these requirements in the inquiry.

Lead precision

Ewellix offers a variety of high precision solutions to meet the requirements of a growing market. Using equipment at the cutting edge of today’s machining capability allows for the precise control of the thread machining. Ewellix positioning ball screws offer the accuracy and performance level of a G5 positioning screw as defined by ISO 3408-3. Standard lead precision is G5, with G3 or G1 lead precision available on request.

Screw lead precision class is primarily defined by the maximum permitted travel variation V_{300p} over a threaded length of 300 mm (↳ **table 2**). Lead precision is measured at 20 °C on the useful stroke l_u . At Ewellix l_u is the threaded length of the shaft minus twice the length l_0 equal to the screw nominal diameter (↳ **table 2** and **fig. 1**).

Some customer applications require a travel compensation c to account for the effect of operating temperature on the lead precision:

- Standard case with $c = 0$ (↳ **fig. 2**)
- Case with specific value of c (↳ **fig. 3**)

Table 1

Maximum permitted travel variation over 300 mm

G1	G3	G5
V_{300p} μm	V_{300p}	V_{300p}
6	12	23

Table 2

Travel deviation and maximum permitted travel variation over the useful travel l_u

l_u over mm	incl.	G1		G3		G5	
		e_p μm	v_{up}	e_p	v_{up}	e_p	v_{up}
0	315	6	6	12	12	23	23
315	400	7	6	13	12	25	25
400	500	8	7	15	13	27	26
500	630	9	7	16	14	32	29
630	800	10	8	18	16	36	31
800	1 000	11	9	21	17	40	34
1 000	1 250	13	10	24	19	47	39
1 250	1 600	15	11	29	22	55	44
1 600	2 000	18	13	35	25	65	51
2 000	2 500	22	15	41	29	78	59
2 500	3 150	26	17	50	34	96	69
3 150	4 000	32	21	62	41	115	82
4 000	5 000			76	49	140	99
5 000	6 300					170	119



Lead precision measurement

Symbols used in figs. 1 to 3

- l_u = useful travel
- l_e = excess travel (no lead precision required)
- l_0 = nominal travel
- l_s = specified travel
- c = travel compensation (difference between l_s and l_0 to be defined by the customer)
- e_p = tolerance over the specified travel
- V = travel variation (or permissible band width)
- V_{300p} = maximum permitted travel variation over 300 mm
- V_{up} = maximum permitted travel variation over the useful travel l_u
- V_{300a} = measured travel variation over 300 mm
- V_{ua} = measured travel variation over l_u

Fig. 1

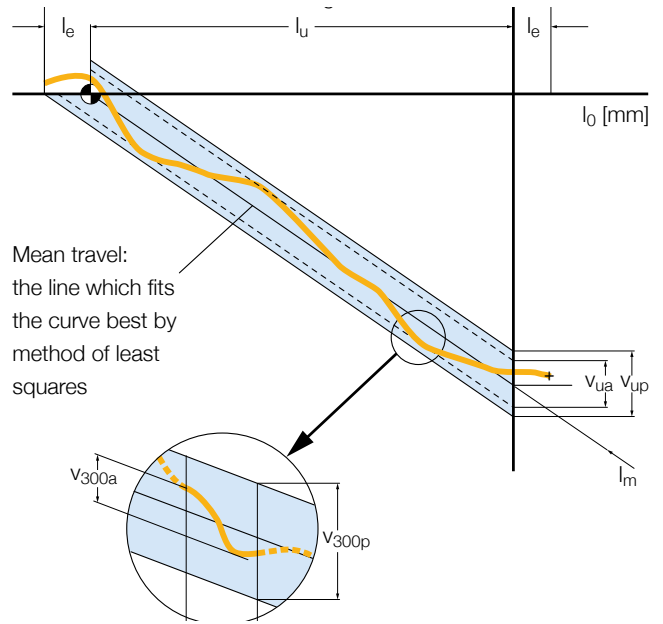

Fig. 2

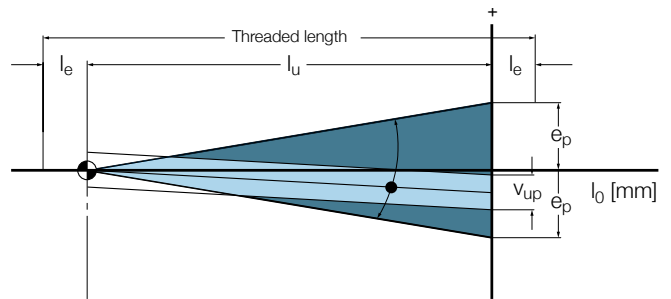
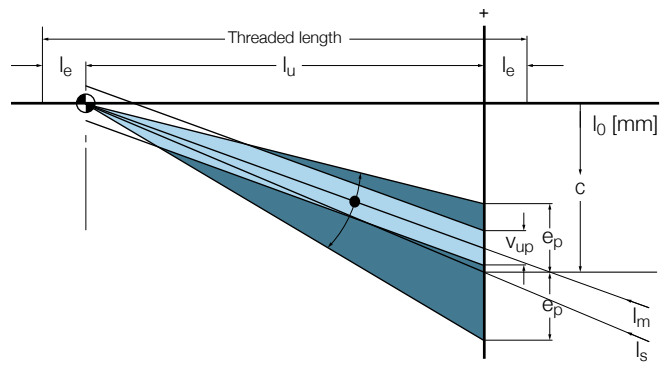

Fig. 3



SP cylindrical nut

Precision ball screw



Technical data

Nom Ø	Lead (RH)	Nut				Screw						
		C _a	C _{0a}	Circuits of balls	Std Play	Reduced Play	Preload Torque - Zero Play	Inertia	Grease	Mass	Mass	Inertia
d ₀	Ph	C _a	C _{0a}	Circuits of balls	Std Play	Reduced Play	Preload Torque - Zero Play	Inertia	Grease	Mass	Mass	Inertia
mm	mm	kN		-	mm		Nm	kg*mm ²	cm ³	kg	kg/m	kg*mm ² /m
30	5	29	76	2X3	0.10	0.05	0.19	181.35	1.70	0.41	5.51	620.31
40	5	58	169	2X4	0.10	0.05	0.38	526.65	3.30	0.72	9.81	1 961.97
	10	98	219	2X3	0.12	0.08	0.83	1 949.36	10.80	1.96	9.69	1 938.05
50	5	64	215	2X4	0.10	0.05	0.53	885.54	4.20	0.86	15.36	4 799.37
	10	112	287	2X3	0.12	0.08	1.18	3 039.48	13.20	2.30	15.24	4 761.99
63	10	156	475	2X4	0.12	0.08	1.63	7 189.53	20.20	3.77	24.29	12 052.94

Notes:

- Lubrication hole is standard.
- Wipers available.
- Customized axial play and backlash elimination available.

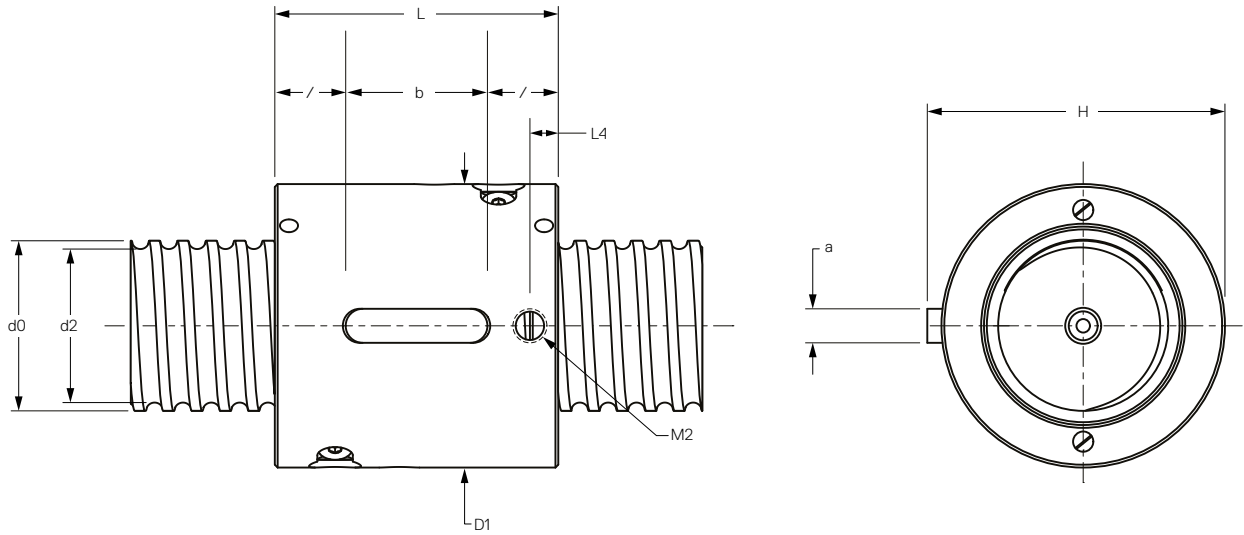

Nut		Key			Screw		
min D1	L	L4	M2	a	H	b	d2
mm							
50	50	5	M6X1	6	52.5	25	27.0
63	62	5	M6X1	6	65.5	32	36.2
76	97	10	M8X1	6	78.5	32	34.1
72	62	5	M6X1	6	74.5	32	46.2
86	97	10	M8X1	8	89.0	40	44.1
102	117	10	M8X1	8	105.0	40	57.1

SPF flanged nut

Precision ball screw



Technical data

Nom Ø	Lead (RH)	Nut				Screw						
		C _a	C _{0a}	Circuits of balls	Std Play	Reduced Play	Preload Torque - Zero Play	Inertia	Grease	Mass	Mass	Inertia
d ₀	Ph	C _a	C _{0a}	Circuits of balls	Std Play	Reduced Play	Preload Torque - Zero Play	Inertia	Grease	Mass	Mass	Inertia
mm	mm	kN		-	mm		Nm	kg*mm ²	cm ³	kg	kg/m	kg*mm ² /m
30	5	21	50	1X4	0.10	0.05	0.19	481.93	1.50	0.71	5.51	620.31
40	5	32	85	1X4	0.10	0.05	0.38	1 046.28	2.50	0.99	9.81	1 961.97
	10	69	146	1X4	0.12	0.08	0.83	3 068.70	6.60	2.37	9.69	1 938.05
50	5	50	161	2X3	0.10	0.05	0.53	1 987.35	3.80	1.35	15.36	4 799.37
	10	79	191	1X4	0.12	0.08	1.18	4 907.00	8.00	2.84	15.24	4 761.99
63	10	122	356	2X3	0.12	0.08	1.63	10 024.43	15.80	4.51	24.29	12 052.94

Notes:

- Lubrication hole is standard.
- Wipers available.
- Customized axial play and backlash elimination available.

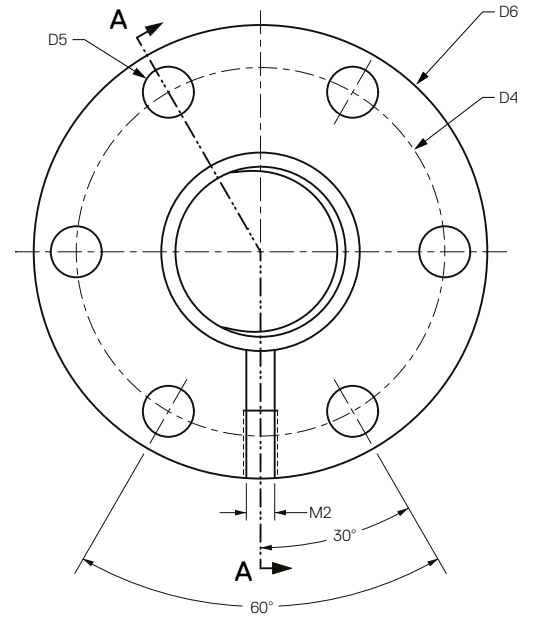
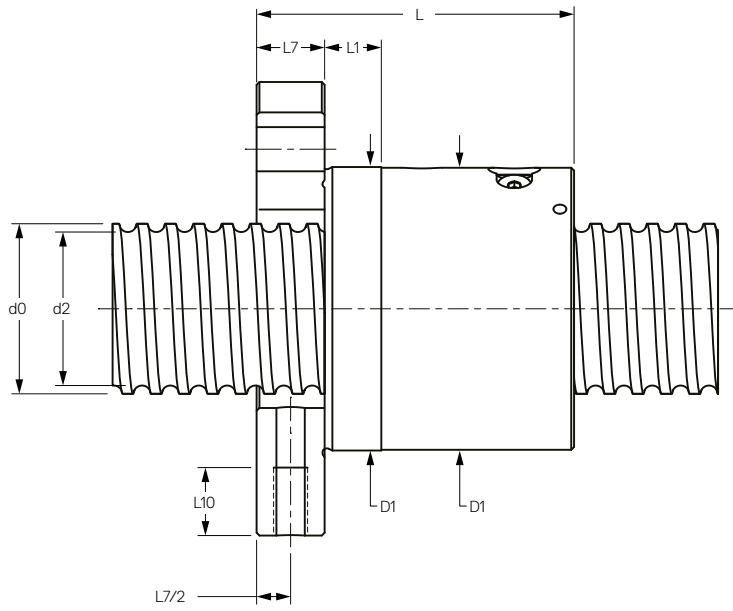

Nut **Screw**

min D1 D4 D5 D6 L L1 L7 L10 M1 M2 d2

mm

50	65	9	80	56.0	10	12	12	N/A	M6X1	27.0
63	78	9	93	58.5	10	14	12	N/A	M6X1	36.2
76	94	9	110	87.0	20	16	12	N/A	M8X1	34.1
72	90	11	110	68.5	10	14	12	N/A	M6X1	46.2
86	106	11	125	87.0	20	16	12	N/A	M8X1	44.1
102	120	11	137	114.0	20	18	12	N/A	M8X1	57.1

SPT nut with threaded nose

Precision ball screw



Technical data

Nom Ø	Lead (RH)	Nut				Screw						
		C _a	C _{0a}	Circuits of balls	Std Play	Reduced Play	Preload Torque - Zero Play	Inertia	Grease	Mass	Mass	Inertia
d ₀	Ph	C _a	C _{0a}	Circuits of balls	Std Play	Reduced Play	Preload Torque - Zero Play	Inertia	Grease	Mass	Mass	Inertia
mm	mm	kN		-	mm		Nm	kg*mm ²	cm ³	kg	kg/m	kg*mm ² /m
30	5	29	76	2X3	0.10	0.05	0.19	212.76	1.70	0.48	5.51	620.31
40	5	58	169	2X4	0.10	0.05	0.38	581.59	3.30	0.79	9.81	1 961.97
	10	98	219	2X3	0.12	0.08	0.83	2 121.79	10.80	2.16	9.69	1 938.05
50	5	64	215	2X4	0.10	0.05	0.53	970.29	4.20	0.96	15.36	4 799.37
	10	112	287	2X3	0.12	0.08	1.18	3 358.04	13.20	2.57	15.24	4 761.99
63	10	156	475	2X4	0.12	0.08	1.63	7 715.60	20.20	4.11	24.29	12 052.94

Notes:

- Lubrication hole is standard.
- Wipers available.
- Customized axial play and backlash elimination available.

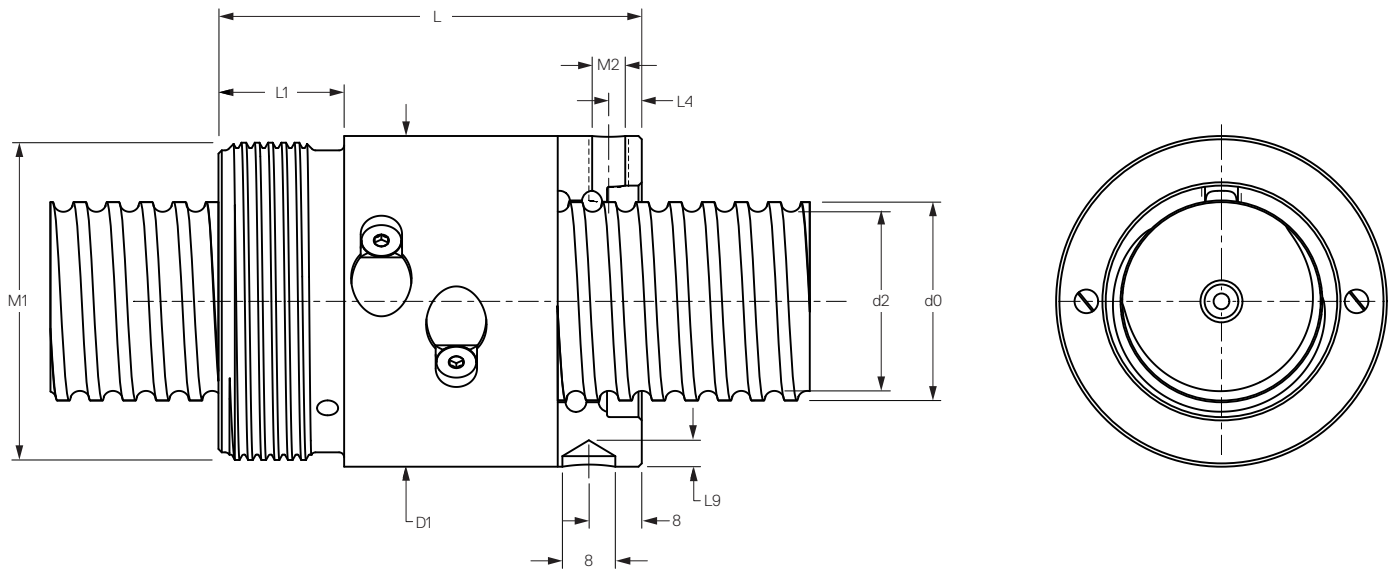

Nut							Screw	
min D1	L	L1	L4	M1	M2	L9	Spanner	d2
mm								
50	64	19	5	M48X1	M6X1	4	HN7	27.0
63	81	24	5	M60X2	M6X1	4	HN9	36.2
76	114	24	10	M72X2	M8X1	5	HN11	34.1
72	81	24	5	M72X2	M6X1	4	HN11	46.2
86	119	29	10	M80X2	M8X1	5	HN14	44.1
102	139	29	10	M94X2	M8X1	5	HN16	57.1

Design calculation and inquiry form

Customer and project information

Company name

Address

Contact name Phone number

Email Website

Project name.....

Application type

Short description of application
(please attach a sketch if possible)

Annual ball screw requirements
and start of production date

Prototype requirements
and suitable delivery date

For existing or modified application,
type of ball screw already used

Ball screw data

Design parameter	Value
Maximum stroke [mm]
Threaded length [mm]
Total length [mm]
Pre-selection of screw shaft nominal diameter d_o [mm]
Pre-selection of lead P_h [mm]
Pre-selection of nut type
Lead precision grade according to ISO 3408
Pre-selection of axial play, backlash elimination or preload
If axial play is selected, preferred min/max range [μm]
Request for accessories (flanges, support bearings, etc.)
Other pertinent information

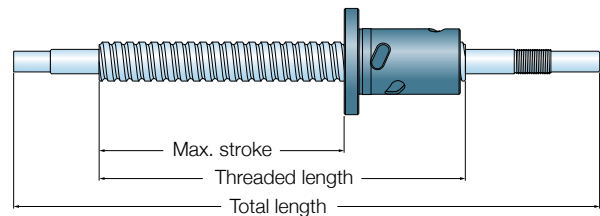

Operating conditions

Maximum loads

- Maximum static load or shock load [N]
- Maximum dynamic load in tension [N]
- Maximum dynamic load in compression [N]

- Average linear speed [m/min]
- Maximum linear speed [m/min]
- Maximum acceleration [m/s²]

Lubrication

- Brand name
- Type
- Viscosity at average operating temperature [cSt]

Operating temperature

- Minimum [°C]
- Average [°C]
- Maximum [°C]

Required service life

- Travel [m]
- Or revolutions [rev]
- Or duration [hours]

Duty cycle description

Step	Axial force [N]	Speed, either rotational speed [rpm] or linear speed [m/minute]	Travel [mm]
1
2
3
4
5
Etc.

Mounting conditions

- Position of the screw Vertical Horizontal
- Rotating part Screw Nut
- Screw end fixing conditions
- N (fixed, free)
 - N (fixed, radial support)
 - N (fixed, fixed)

Other pertinent information

.....

.....

.....

.....

Ball screw catalogue, ball screw 2D prints and 3D models are available on www.ewellix.com
 Please send inquiry form to your Ewellix sales office. For contact information, please visit www.ewellix.com

Ordering key

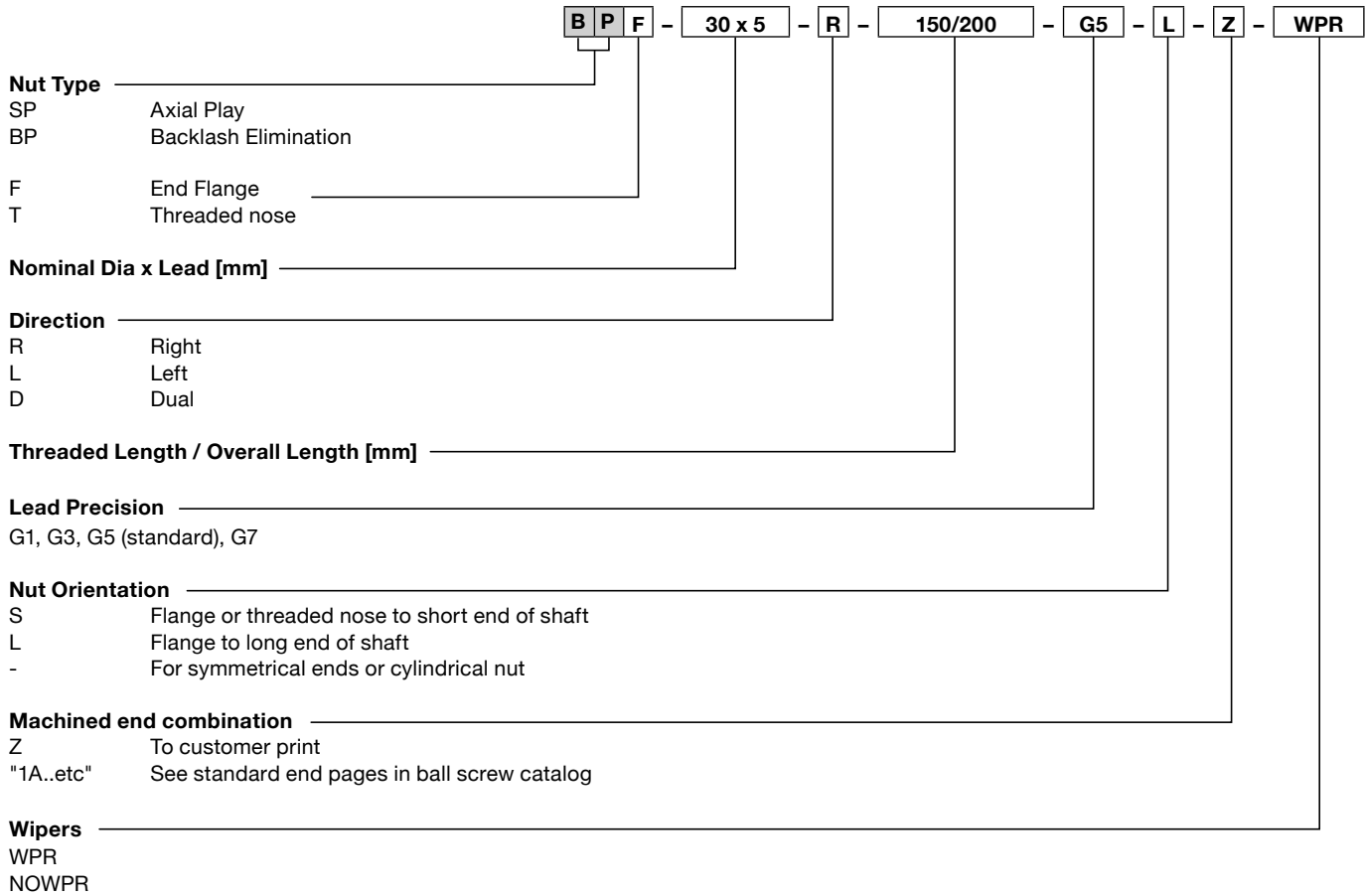

Made in the USA

Download

For complete details download the full Precision rolled ball screw catalog.





ewellix.com

© Ewellix

All contents of this publication are the property of Ewellix, and may not be reproduced or given to third parties (even extracts) without permission. Although great care has been taken in the production of this catalog, Ewellix does not take any responsibility for damage or other loss resulting from omissions or typographical errors. The photo may differ slightly in appearance from the actual product. Due to continuous improvements being made in our products, the product's appearance and specifications are subject to change without notice.

PUB IL-06020-EN-US-May 2021