

**EWELLIX**

A Schaeffler Company

# Solutions for imaging equipment



# The heritage of innovation

Ewellix is a global innovator and manufacturer of linear motion and actuation solutions. Our state-of-the-art linear solutions are designed to increase machine performance, maximise uptime, reduce maintenance, improve safety and save energy. We engineer solutions for assembly automation, medical equipment, mobile machinery, distribution and a wide range of other industrial applications.

## Technology leadership

We earned our reputation through decades of engineering excellence. Our journey began over 50 years ago as part of the SKF Group, a leading global technology provider. Our history provided us with the expertise to continuously develop new technologies and use them to create cutting edge products that offer our customers a competitive advantage.

In 2019, we became independent and changed our name to Ewellix. We are proud of our heritage. This gives us a unique foundation on which to build an agile business with engineering excellence and innovation as our core strengths.

## Global presence and local support

With our global presence, we are uniquely positioned to deliver standard components and custom-engineered solutions, with full technical and applications support around the world. Our skilled engineers provide total life-cycle support, helping to optimise the design, operation and maintenance of equipment thus improving productivity and reliability while reducing costs. At Ewellix, we don't just provide products; we engineer integrated solutions that help customers realise their ambitions.

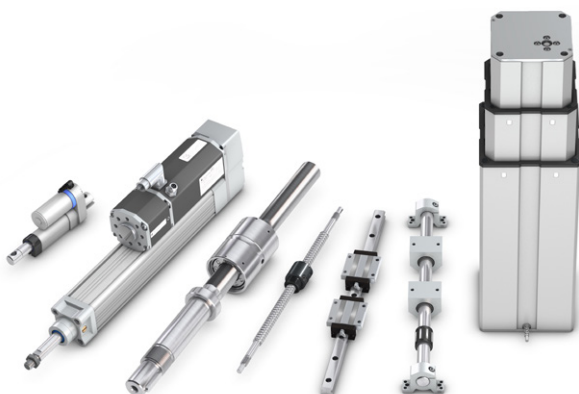

## Schaeffler Group – We pioneer motion

Ewellix is since 2023 owned by the Schaeffler Group.

As a leading global supplier to the automotive and industrial sectors, the Schaeffler Group has been driving forward groundbreaking inventions and developments in the fields of motion and mobility for over 75 years.

With innovative technologies, products, and services for electric mobility, CO<sub>2</sub>-efficient drives, Industry 4.0, digitalization, and renewable energies, the company is a reliable partner for making motion and mobility more efficient, intelligent, and sustainable.

Schaeffler manufactures high-precision components and systems for powertrain and chassis applications as well as rolling and plain bearing solutions for a large number of industrial applications.



# The way to care

In today's medical world, high efficiency and safety are key requirements. Hospital environments become increasingly complex and expensive; effectiveness, reliability and speed are crucial at a higher regulation level.

Doctors need to be precise in their diagnostics and fast. They must rely on their equipment during their examination and imaging procedures.

Workflow and speed are equally important, as is patient safety and ergonomic support. Focus on quality and reliability, coupled with supporting and monitoring services, can put a healthcare device manufacturer at the forefront of medical imaging instead of the healthcare device industry.

At Ewellix, we have an in-depth understanding of the medical device industry and based on our 30's years of experience and gained knowhow, we have developed a unique range of products and services for our advanced actuation and guiding solutions, manufactured to meet the latest industry's requirements and to comply with necessary healthcare specifications and regulations, such as EN and UL standards.

From concept to product launch, Ewellix strives to achieve the best quality and highest safety standards.



Ewellix offers a full range of products specially designed for medical applications, which provide:

- High performance and reliability
- Compact and robust designs
- Compliance with standards and regulations
- Extensive industry experience and knowledge
- Global presence and knowledge support

## Imaging trend

- Productivity and patient flow improvement
- Higher safety standards and more regulations
- Aging of the world population
- Increasing obesity and patient weight

## Value proposition

- Safe and reliable lifting and linear motion
- Quiet and friction-less movement
- Highest load capacity and speed
- Comply with standards and regulations

# General x-ray

Our state-of-the-art x-ray equipment ranges from motionless to fully electrically synchronised motion sequences. We are the first choice for patient tables (Bucky tables), ceiling supported x-ray tubes, and highly flexible wall stands and complete (U-shaped) solutions. Ewellix not only helps you to improve patient comfort, but we also improve the functionality of your equipment, particularly in the area of lifting and sliding tables.

Our medically certified electrical lifting columns and actuators, combined with our wide range of cutting-edge linear guides, ensure faster time to market. Ewellix would be delighted to demonstrate the quality of our products to you for your next development project.

## Ewellix solutions

### Features

- Higher productivity
- Easily accessible patient table
- Equipment for manual and motorised adjustment
- Compact ceiling-mounted systems
- Increasing regulation and norms (UL/EN 60601)
- Caters to trend in increasing obesity

### Benefits

- More functionality, combined with high load and speed capability
- Optimal combination of minimum retracted length and extended stroke length
- High knowledge and expertise in medical imaging applications
- Lowest friction linear guides for manual movements
- Products in compliance with norms and regulations
- Silent and smooth motion with soft-start and -stop functionality

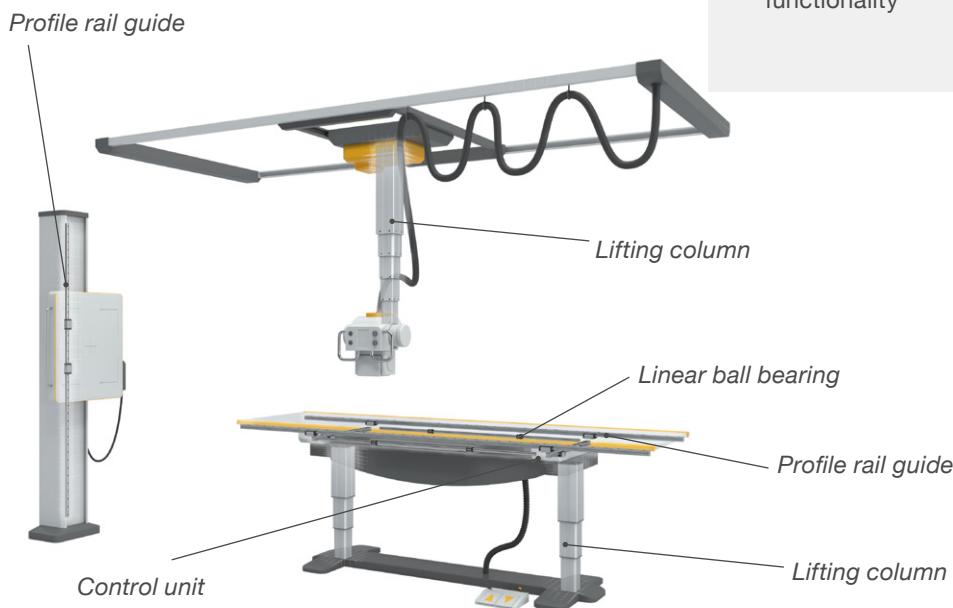

### Lifting columns

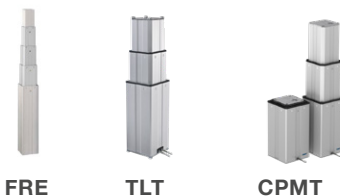

### Linear actuators



RUNNER

### Control boxes



SCU

### Profile rail guides



LLT

### Linear ball bearings



LBBR

# Mobile C-arm

Mobile C-arms are the first choice when it comes to emergency room equipment due to their unrivalled flexibility. The variety of products available range from simple systems to fully electric motion solutions for angiographic examinations.

Ewellix has been providing premium quality electrical lifting columns for this purpose for decades. We are renowned for our bespoke customer-specific installation solutions, as well as cable bushings.

Our robust and solid column construction allows high torque with maximum safety. You can position the C-arm in any direction using our state-of-the-art profile rails. At Ewellix, we would be more than happy to support you during your next development project.

## Ewellix solutions

### Features

- Additional capability for cardio-vascular imaging
- Fast, easily adjustable equipment
- Increasing regulation and norms (UL/EN 60601)
- Quiet operation provides a better environment for patients and professionals

### Benefits

- More functionality combined with controlled motion
- Low-friction motion for hand movements
- Products in compliance with norms and regulations
- Solutions for higher offset loads
- Silent movement with soft start-and-stop functionality

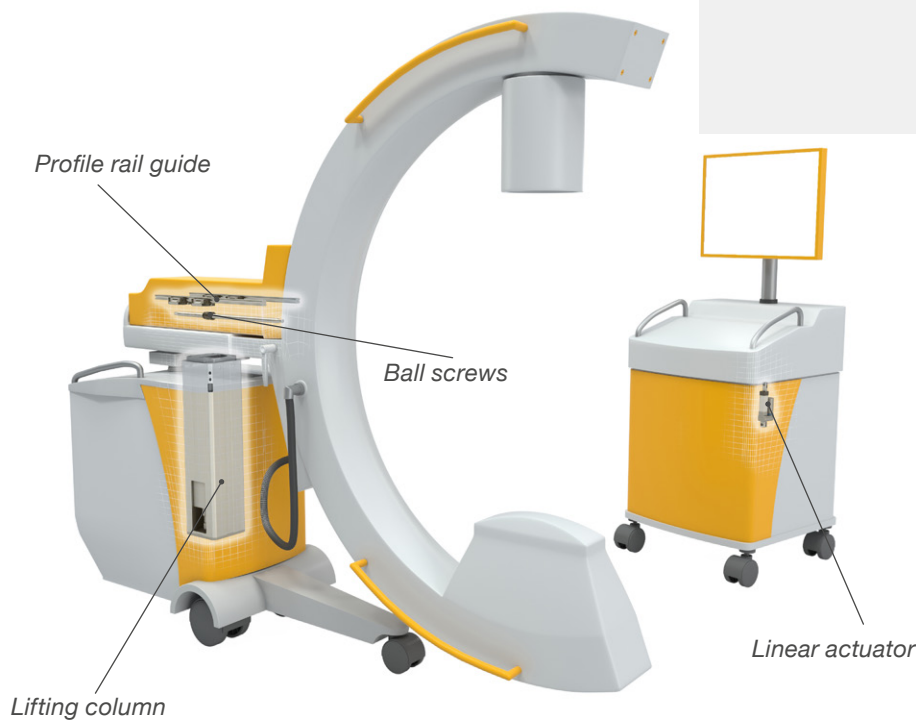

#### Lifting columns



**TLG**



**CPMC\***

#### Linear actuators



**ECOMAG**

**MAX7**

#### Control boxes



**BCU**

#### Profile rail guides



**LLT**

#### Ball screws



**SP**

\* Customized C-arm offer (available on request, ↳ page 14)

# CT patient tables and scanners

Modern CT devices should be as comfortable and efficient as possible, capable of satisfying the rising geriatric population. To achieve this, manufacturers must combine both a comfortable low entry height for their patients and achieve excessive lifting capacities. There is also the need to optimise patient flow whilst reducing CT times and minimising radiation exposure.

Ewellix's wide range of high quality, reliable off-the-shelf and tailor-made solutions offer you the possibility to dramatically reduce overall cycle time, increase patient comfort and improve the quality of the high-resolution images thanks to high lifting speed, the optimised ratio between built-in size and high stroke, such as smooth and precise motion. Let us convince you about our cutting-edge solutions.

## Ewellix solutions

### Features

- Improved high-resolution imaging
- Shorter examination cycles
- Accuracy in mechanical motion
- Easy patient table access
- Increasing regulation and norms (UL/EN 60601)
- Caters for trends in increasing obesity
- Optimum physical and emotional environment for patients

### Benefits

- More functionality, combined with increased speed
- Knowledge and expertise in motions technology
- Precision in linear motion and guiding
- Optimal lift combination of minimum retracted length and extended stroke
- Products in compliance with norms and regulations
- Solutions for more load-carrying capacity
- Silent movement with soft start-and-stop functionality

Linear actuator

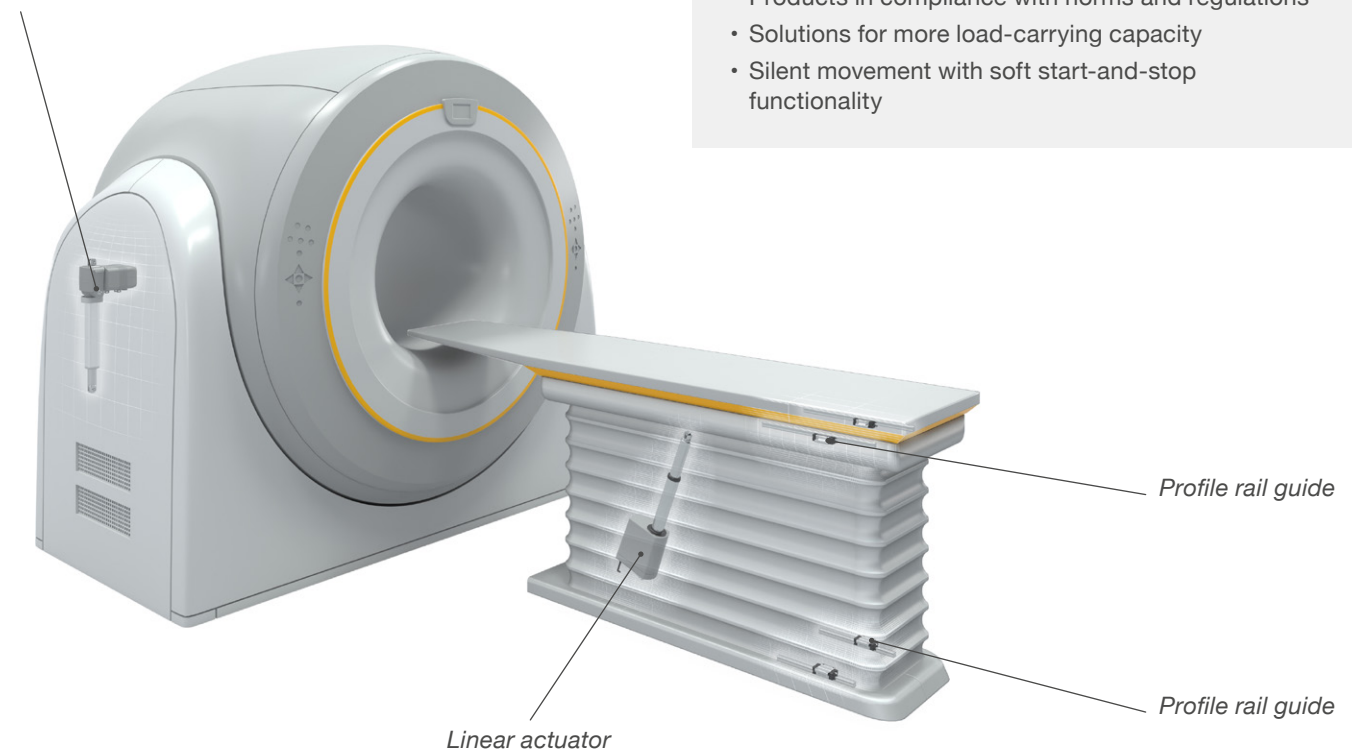

Lifting columns



CPMT

TLT

Linear actuators



RUNNER

MAX3

MAX7

Control boxes



VCU/SCU

Profile rail guides



LLT

LLS

# MRI

The growing geriatric population, both in developed and developing economies, plus an increase in chronic diseases globally, has driven the demand for technological advanced MRI systems to detect and diagnose abnormalities within the body.

Ewellix's proven know-how in linear motion solutions can help speed up the development of your next-generation MRI system. For years, we have supplied a wide range of top quality, reliable off-the-shelf and tailor-made solutions adding value and providing greater flexibility to medical imaging systems. Our robust and renowned actuators and telescopic columns are easy to install, medically approved and provide high rigidity.

Let us convince you about our cutting-edge solutions.

## Ewellix solutions

### Features

- Easily accessible patient table
- Improved high-resolution imaging
- Increasing regulation and norms (UL/EN 60601)
- Higher examination efficiency through fast and smooth motion
- Caters for trends in increasing obesity

### Benefits

- Optimal lift combination of minimum retracted length and extended stroke
- Products in compliance with norms and regulations
- Solutions for more load-carrying capacity
- Silent and smooth movement with soft-start and -stop functionality



#### Lifting columns



CPMT

TLT

#### Linear actuators



RUNNER

#### Control boxes



VCU/SCU

# Angiography patient tables

Patients who must undergo a cardiac catheter examination or coronary angiographs require a high degree of comfort and safety, whilst the most crucial factor for medical staff is to ensure that their surgical procedures run as smoothly as possible.

The crucial requirements in ensuring optimum control of radiation exposure for patient operation tables are flexible table heights that allow comfortable working conditions and maximum linear movements of their telescopic columns.

Ewellix's wide range of products includes ball and roller profile rails for maximum rigidity and stability and purpose-made actuators for lifting and tilting. Our unique precision rail guides provide unparalleled smoothness in tabletop movements.

We would be more than delighted to assist you with your specific requirements.

## Ewellix solutions

### Features

- Highest accuracy in patient positioning
- Lowest rolling friction in linear guides
- High safety with linear guides
- Solutions to increase safety factors
- Reliable with "Anti Creeping System"
- Excellent permanence compactness ratio

### Benefits

- Knowledge in imaging applications
- Smooth and nearly frictionless motion
- Best for manual patient table moves
- Proven and reliable industry solutions

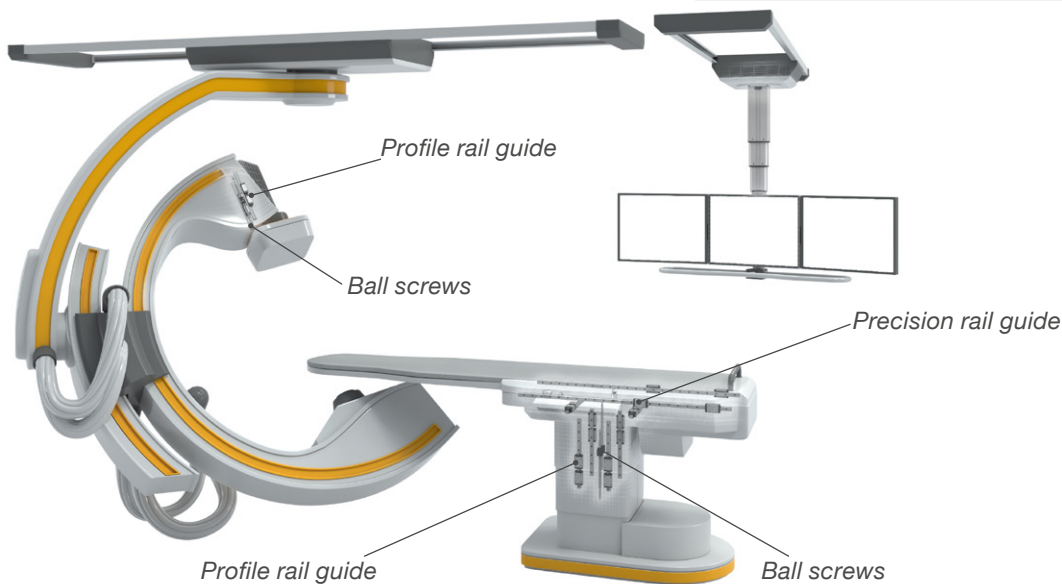

Profile rail guides

Precision rail guides

Ball screws

Linear actuators



LLT

LLU

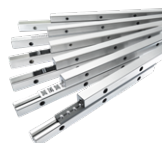

LWR / LWRE



SP



RUNNER

MAX3



# Oncology patient tables

Cancer therapies with high radiation doses require extreme precision and repetitive accuracy. Extremely rigid and reliable tables with the highest accuracy reduce the risk of adverse reactions for patients. For treatment purposes, the table must be able to move in practically all directions.

Ewellix planetary roller screws and profile rails are an effective and reliable choice for improving repeatability in table positioning. We have long been the world leader in this market.

Our precision rail guides guarantee longitudinal movements that deliver maximum stability and optimum positioning accuracy, at the same time minimising friction.

## Ewellix solutions

### Features

- Shorter examination times
- High accuracy in mechanical motion
- Easy patient table access
- Increasing regulation and norms (UL/EN 60601)
- Lifetime usage without maintenance

### Benefits

- Cutting-edge technology with increased speed
- Knowledge in high-precision rotation and linear motion
- Solutions for ultimate load-carrying capacity
- Products in compliance with norms and regulations
- Virtually maintenance-free solutions

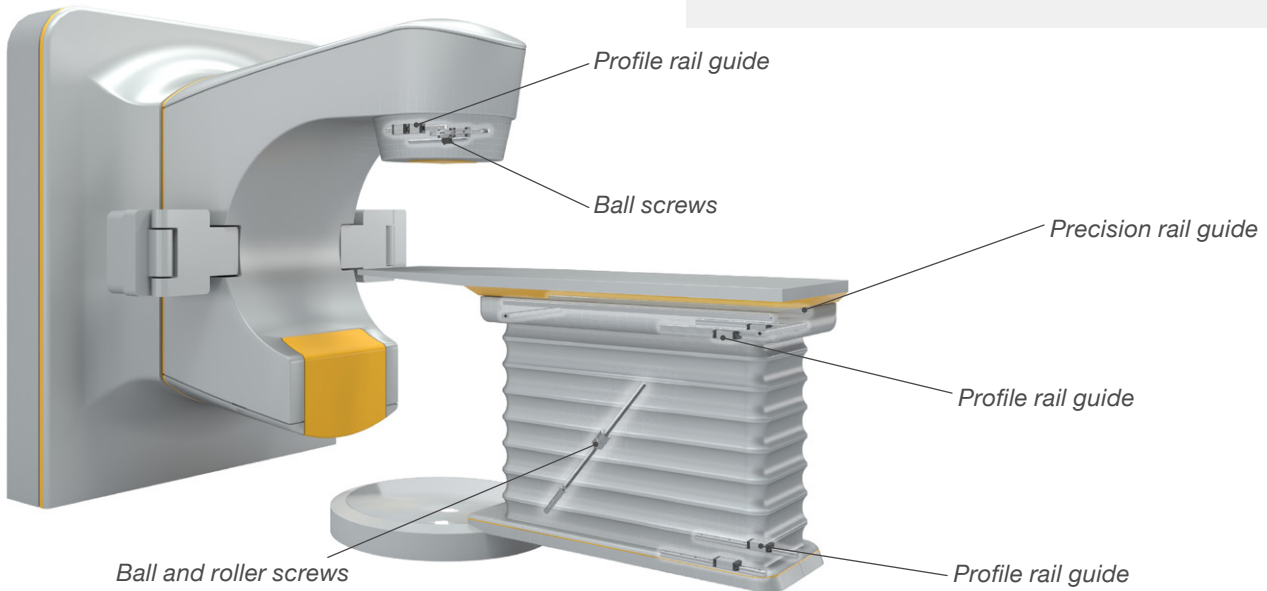

Profile rail guides



LLT

LLU

Precision rail guides

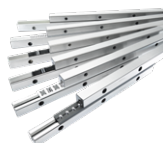

LWRE / LWRM, V

Ball and roller screws



SR

SV

SP

# Mammography

Thus, the growing prevalence of breast cancer the demand in technological advanced breast imaging systems is growing to enable early detection. Modern digital mammography systems providing the highest depth resolution diagnostic accuracy and enabling comfortable and relaxed patient care, must be efficient and cost-effective.

Ewellix offers a wide range of perfectly tailored solutions. Lifting becomes easy when using one of our smooth-running telescopic columns or an actuator combined with our high-quality profile rail guides. For the adjustment of the collimator, detector and compression paddle, our precise and reliable miniature profile rail guides and ball screws are the right choices.

## Ewellix solutions

### Features

- Improved high depth resolution imaging
- Enhanced productivity and cost-effectiveness
- Patient-friendly and comfortable examination
- Increasing regulation and norms (UL/EN 60601)
- Lifetime usage without maintenance

### Benefits

- Precision in linear motion and guiding
- Compact drive solutions with a high lifting speed
- Optimal lift combination of minimum retracted length and extended stroke
- Products in compliance with norms and regulations
- Silent and smooth motion with soft-start and - stop functionality
- Virtually maintenance-free solutions

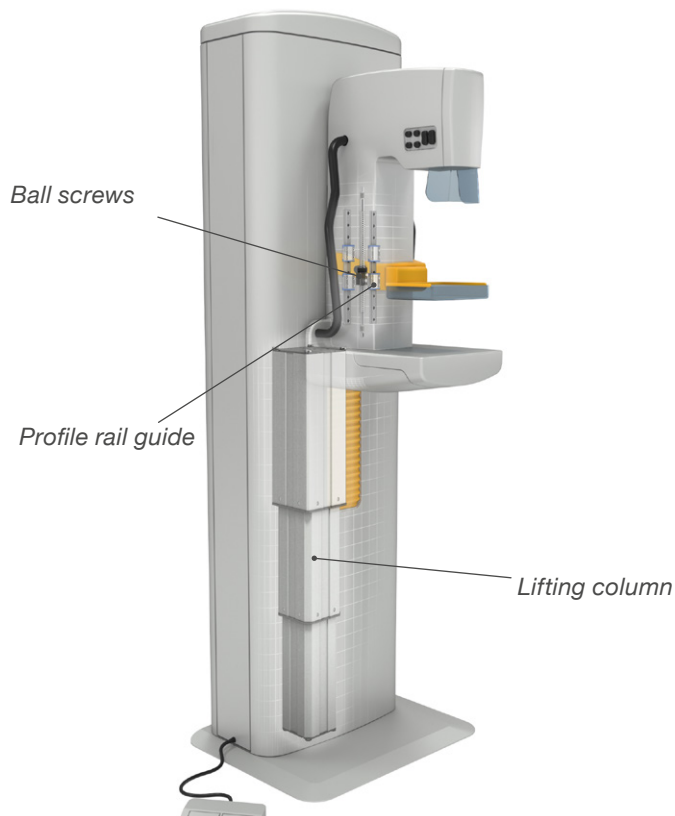

Lifting columns

Linear actuators

Control boxes

Profile rail guides

Ball screws



TLG

TLT



MATRIX



BCU



LLT



LLS



SP

# Dental x-ray

Increasingly, both 2D and 3D imaging systems are being used to improve teeth reconstruction under real-time conditions. 3D panoramic images not only reveal defects but also provide data for modelling dental prostheses. Ewellix offers lifting devices designed to ease patient examination for 3D imaging systems. Our range includes tailor-made long-stroke actuators and low-noise lifting columns. Motion control is achieved in the imaging system headpiece by using high-precision miniature profile rail guides.

## Ewellix solutions

### Features

- Wide adjustment range
- Increased load range to carry the required equipment
- Enhanced productivity and cost-effectiveness
- Patient-friendly and comfortable examination
- Increasing regulation and norms (UL/EN 60601)
- Lifetime usage without maintenance

### Benefits

- Long lifting stroke at compact retracted size
- High lifting load and speed capability
- Smooth and nearly frictionless guiding
- Products in compliance with norms and regulations
- Silent and smooth motion with soft-start and - stop functionality
- Virtually maintenance-free

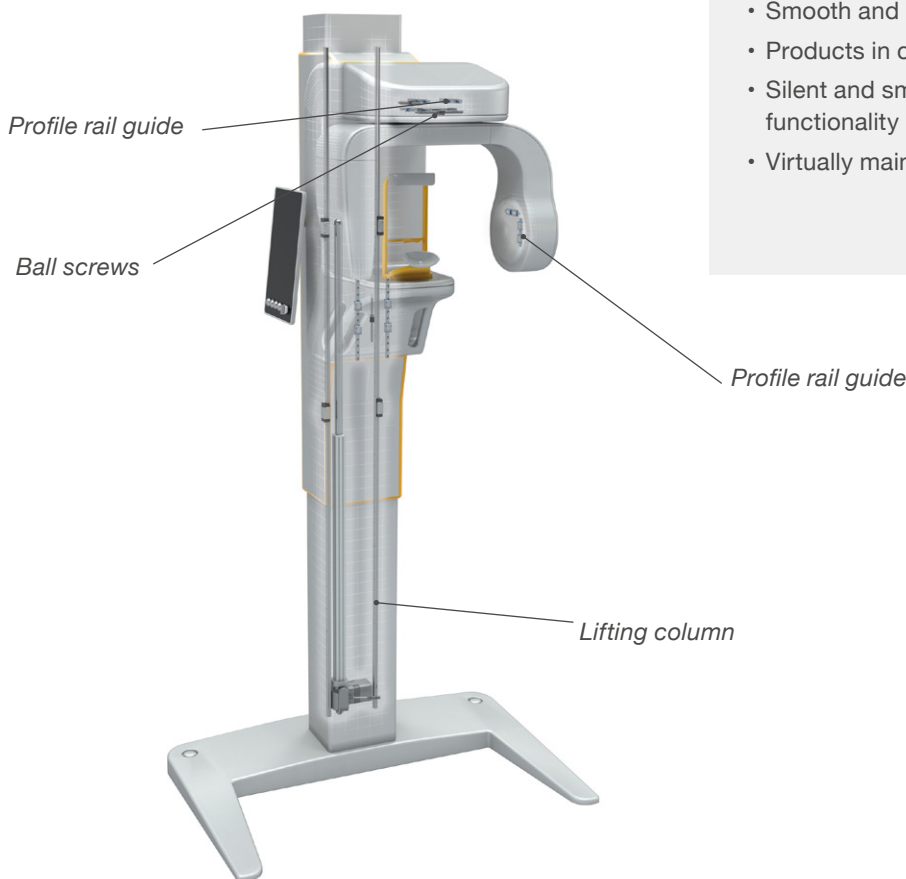

#### Lifting columns



TFG

TLG

#### Linear actuators



MATRIX

#### Control boxes



BCU

#### Profile rail guides



LLT



LLS

#### Ball screws



SP

# Products overview

## Lifting columns



	TLG10-C	TLT10-C2	TFG	TLG10-A	CPMC*	CPMT1-1S
Rated push load	1 500 N	2 000 N	2 500 N	4 000 N	4 000 N	5 000 N
Speed	25 to 33 mm/s	25 to 42 mm/s	15 to 19 mm/s	10 to 14 mm/s	up to 25 mm/s	14 to 34 mm/s
Retracted length	Stroke + 180 mm	Stroke/2 + 240 mm	Stroke + 130 mm	Stroke + 180 mm	Stroke + 200 mm	Stroke/2 + 120 mm
Bending load	Up to 950 Nm	up to 480 Nm	up to 500 Nm	Up to 2 800 Nm	3 000 Nm	up to 450 Nm
Stiffness	+++	++++	+	+++	++++	+

\* Customized C-arm offer (available on request, [L](#) page 14)

## Linear actuators



	ECO5	MAX3/7-C	MAX3/7-A	RU20	RU24
Rated push load	2 000 N	3 000 N	8 000 N	8 000 N	10 000 N
Rated pull load	2 000 N	3 000 N	6 000 N	8 000 N	10 000 N
Speed	9 to 13 mm/s	13 to 18 mm/s	5 to 7.5 mm/s	7 to 10 mm/s	6 to 12 mm/s
Retracted length	Stroke + 160 mm	Stroke + 215 mm	Stroke + 215 mm	Stroke + 215 mm	Stroke + 215 mm

## Control boxes



	BCU	VCU	SCU
Motor ports	3	3 or 5	3 or 6
Output voltage (nominal)	24 VDC	24 VDC	24 VDC
Total output current (max)	7A	7 A / 18 A	18A / 30A
Operating device ports	1	2	3
Soft Start/Stop	✓	✓	✓
Encoder processing	-	-	✓
Memory Functions	-	-	✓
Configurable binary inputs / outputs	-	2 / 0	2 / 4
Configurable smart functionality	-	-	✓
Optional battery	-	✓	✓
Optional RS232 interface	-	-	✓

## Linear guides

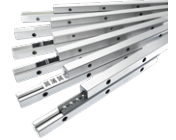
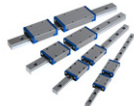

	LB-range	LLS-range	LLT-range	LLU-range	LW-range
Size and range	3 to 80	7 to 15	15 to 45	25 to 65	2 to 9
Dynamic load rating	up to 37,5 kN	up to 12,5 kN	up to 72,5 kN	up to 276 kN	more than 300 kN
Speed	up to 5 m/sec	up to 5 m/sec	up to 5 m/sec	up to 3 m / sec	more than 10 m/sec
Acceleration	up to 100 m/ sec <sup>2</sup>	up to 140 m/ sec <sup>2</sup>	up to 75 m/ sec <sup>2</sup>	up to 50 m/ sec <sup>2</sup>	up to 160 m/ sec <sup>2</sup>
Accuracy	up to 50 µm at 4 m	up to 10 µm at 2 m	up to 18 µm at 4 m	up to 7 µm at 4 m	up to 2 µm at 1 m
Material options	Stainless steel	Stainless steel	Coatings	–	Stainless steel or coated
Characteristics	Easy integration	Miniature sizes	Economic solution	High load capacity	Precise with lowest friction

## Ball and roller screws



	SP	SR	SV
Diameter	8 to 16	8 to 39*	10 to 32*
Lead	2 to 5	2 to 10*	1 to 2
Max push/pull load	1 000 to 5 000 N	2 000 to 90 000 N	2 000 to 30 000 N
Max speed**	1 000 mm/s	1 000 mm/s	400 mm/s
Backlash free option	✓	✓	✓
Preload option	–	✓	✓

\* Higher sizes, leads and speed available in standard for more demanding applications.

\*\* Value varies depending on diameter and lead. Most favourable case.

# Our expertise, your success

Ewellix has expertise in developing unique products with a perfect fit for specific applications. With the CPMC lifting column, built especially for high-end mobile C-arm machines, Ewellix has again proven its outstanding development skills for highly customised products. Thanks to the all-new guiding tube system and its patented glider design, the lifting column can handle high offset loads of up to 3 000 Nm and nominal loads of 4 000 N together. The column is equipped with an advanced BLDC motor with high power density, providing sufficient power for lifting high loads at high speed.

Another benefit is that the built-in BLDC encoder can be used for position feedback, enabling precise positioning of the lifting column. The rotational motion is transmitted into vertical lifting motion via a highly efficient ballscrew, improving overall energy efficiency and wear and tear.

## Features

- Extremely high offset load capability
- High lifting loads and speed
- Virtually maintenance-free
- High level of product safety
- Multiple options to customise the product

As a safeguard, the column is equipped with the following safety features:

- Back-up nut – preventing the column from collapsing in case the primary nut fails
- Self-locking wrap spring brake system – preventing the column from moving back at any running conditions
- Mechanical end limits – limiting the travel of the drivetrain mechanically before collapsing, in case the stroke limitation monitoring fails
- Manual operation – An extended gear shaft at the bottom side enables manual adjustment in case of power loss or similar defects

Both the top and bottom attachment plates can be designed according to your needs, as well as the configuration of the cable feedthroughs and chains, making your CPMC lifting column capable of meeting all your requirements. Below you can find an overview of the options available.



External cable chain



Externally mounted encoder system at motor or potentiometer



External end limit switches

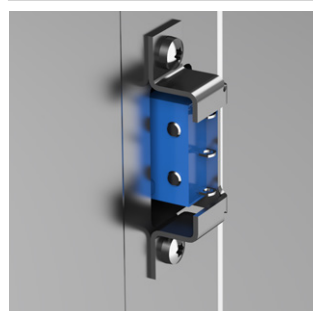

Customized top and bottom plate

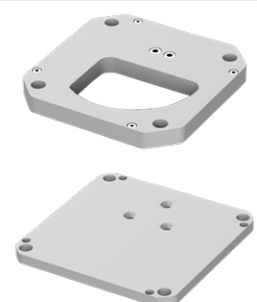

# Supporting tool

## Digital

Ewellix has developed a portfolio of tool to support customers in easy selection and calculation the right Ewellix product for their application.

### Actuators

- Product selection
- Performance calculator
- Cost saving calculator

### Ball and roller screws

- Product selection
- Product calculator
- Product verification

### Linear guides

- Product selection
- Product calculator
- Cross reference

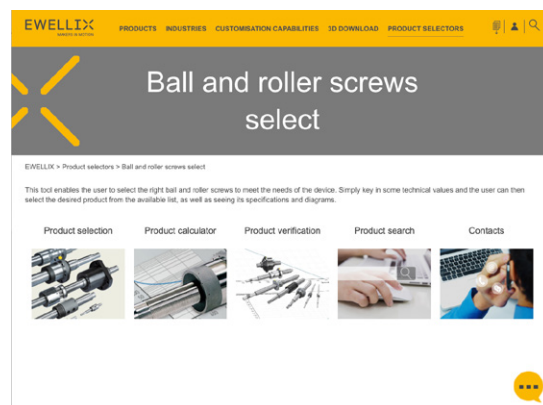
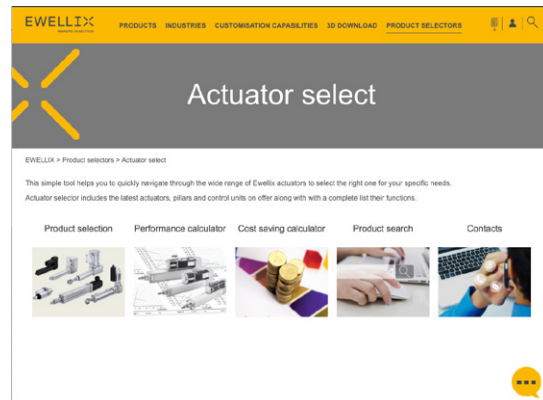

## Publications

Supporting documents are available for downloading on ewellix.com in each product page under technical data section:

- operating manual
- mounting instruction

**Actuator range**



**Linear bearings units and shafts**



**Miniature profile rail guides LLS**



**Precision rolled ball screws**



**Precision rail guides**



**Profile rail guides LLU**



**Roller screws**



**Profile rail guides LLT**



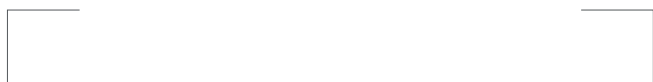

## **ewellix.com**

© Ewellix

All contents of this publication are the property of Ewellix, and may not be reproduced or given to third parties (even extracts) without permission. Although great care has been taken in the production of this catalog, Ewellix does not take any responsibility for damage or other loss resulting from omissions or typographical errors. The photo may differ slightly in appearance from the actual product. Due to continuous improvements being made in our products, the product's appearance and specifications are subject to change without notice.

**PUB NUM EL-03007/2-EN-February 2023**

Certain image(s) used under license from Shutterstock.com.  
Schaeffler and Schaeffler logo are trademarks of the Schaeffler Group