

INSTALLATION, OPERATION AND MAINTENANCE MANUAL

Linear Modules - CLSM

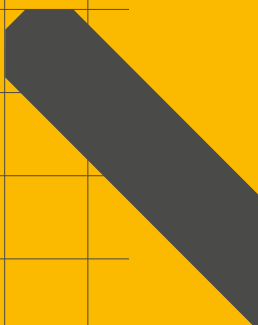

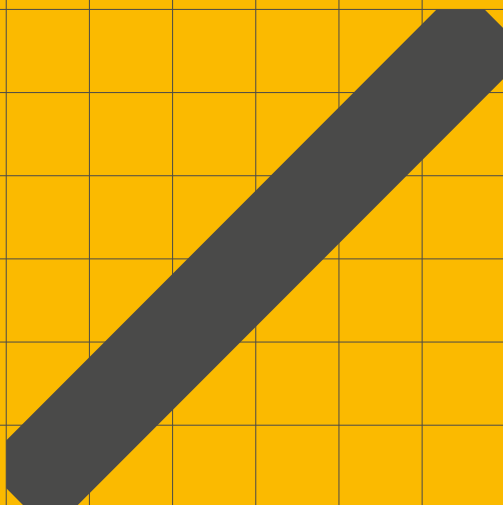

Contents

1.0 General information	4	6.0 Installation	17
1.1 Information in this manual	4	6.1 Installation location	17
1.2 Explanation of symbols and signal words	4	6.2 Inspections prior to initial operation	17
1.3 Limitation of liability	5	6.3 Installation	17
1.4 Copyright	5	6.4 Turning device on and off.....	18
1.5 Spare parts.....	5	7.0 Operation	19
1.6 Warranty terms	5	7.1 Safety	19
1.7 Customer service	5	7.2 Normal operation	19
2.0 Safety	6	7.3 Action before use	19
2.1 Hazard potential	6	7.4 Emergency disengagement	19
2.2 Intended use	7	7.5 Action after use	20
2.3 Essential performance	7	7.6 Installation instruction CLSM inline kit.....	20
2.4 Responsibility of the owner and processor	7	8.0 Maintenance	23
2.5 Authorized personnel	8	8.1 Maintenance plan	23
2.6 Modifications to the device.....	8	8.2 Maintenance work	23
2.7 General safety advice.....	8	8.3 Measures after maintenance completed.....	25
2.8 Electrical safety	9	8.4 Maintenance checks	25
2.9 Disclaimer of liability	9	9.0 Malfunctions	26
3.0 Technical data	10	9.1 Malfunction table	27
3.1 Operating conditions.....	10	9.2 Start of operation after fixing malfunction.....	27
3.2 Product label.....	10	10.0 Dismantling	28
3.3 Safety sign labels attached on the device	10	10.1 Dismantling of the CLSM linear module	28
4.0 Structure and function	11	10.2 Disposal.....	28
4.1 Brief description	11	11.0 Appendix	29
4.2 Direction of motor during operation	14		
4.3 Sensor mounting.....	14		
5.0 Delivery, Packaging and Storage	15		
5.1 Safety information for transporting.....	15		
5.2 Delivery inspection.....	15		
5.3 Returning module to the manufacturer.....	16		
5.4 Packaging.....	16		
5.5 Storage.....	16		

WARNING

Read this manual before installing, operating or maintaining this actuator. Failure to follow safety precautions and instructions could cause actuator failure and result in serious injury, death or property damage.

1.0 General information

1.1 Information in this manual

This manual provides important information on how to work with the linear module (also called device or drive) safely and efficiently.

The manual is part of the device, must always be kept near the device and should be available for personnel to read at any time. All personnel working with the device must read and understand this manual before starting any work. Strict compliance with all specified safety notes and instructions is a basic requirement for safety at work.

Moreover, the accident prevention guidelines and general safety regulations applicable at the place of use of the device must also be complied with.

For a better representation of the circumstance of use, the illustrations used are not necessarily to scale and may vary from the actual design of the device.

1.2 Explanation of symbols and signal words

Safety precautions

Safety precautions are identified by symbols and signal words as shown on the right side in this chapter. The signal words indicate the severity of the hazard and the chance it could occur.

Follow these safety precautions and act cautiously in order to avoid accidents resulting in personal injury and damage to property.

DANGER

Indicates a dangerous situation, which will lead to death or serious personal injury, if the precautionary measures are ignored.

WARNING

Indicates a dangerous situation, which can lead to serious personal injury or death, if the precautionary measures are ignored.

CAUTION

Indicates a dangerous situation, which can lead to minor or moderate injury, if the precautionary measures are ignored.

NOTICE

Indicates a dangerous situation, which can lead to minor or moderate property damage, if the precautionary measures are ignored.

NOTE

Emphasizes useful hints and recommendations as well as information for efficient and trouble-free operation.

1.3 Limitation of liability

All information and notes in this manual were compiled by considering applicable standards and regulations, the present status of technology and our years of knowledge and experience.

The manufacturer will not be liable for damage to the linear module or the equipment into which the linear module has been installed resulting from:

- Disregarding this manual
- Unintended use
- Employment of untrained personnel
- Unauthorized conversions
- Technical modification
- Manipulation or removal of the screws on the device
- Use of unapproved spare parts

If the linear module is customized by Ewellix, the actual product delivered may be different from what is described in the manual. In this case, ask Ewellix for any additional instructions or safety precautions relevant to these devices.

We reserve the right to make technical modifications to the linear module to improve usability.

1.4 Copyright

This manual is protected by copyright law and exclusively to be used internally by Ewellix customers.

Passing this manual on to third parties, duplication of any kind – even in the form of excerpts – as well as the external use and/or disclosure of the Contents without the written consent of the manufacturer is not permitted.

Ewellix reserves the right to seek compensation for violations of these restrictions.

1.5 Spare parts

The CLSM linear module is not meant to be repaired by customer personnel. All warranty and service claims become void without notice if any screws on the linear module have been loosened or removed.

WARNING

Safety hazard caused by use of non-genuine spare parts

Wrong or faulty spare parts can adversely affect safety and cause serious injury, damage, malfunction or total failure.

Therefore:

- Spare parts in/on the device may only be replaced by the manufacturer.

The device must be dismantled and sent to the manufacturer for repair and replacement of spare parts. The address where to send the device back for repair is listed on the back cover of this document.

1.6 Warranty terms

The applicable and effective warranty terms are those contained in the manufacturer's terms and conditions of sale.

1.7 Customer service

Ewellix Customer Service is always available to provide technical information and answer questions.

See the contact information for Ewellix Customer Service on www.ewellix.com

2.0 Safety

These operating instructions contain basic guidelines that have to be observed during mounting, operation and maintenance of the CLSM linear module series. It is imperative that these instructions, particularly the “Safety” section, be thoroughly studied and understood by the fitter and any skilled workers or operators prior to mounting and start-up. If there is any uncertainty or doubt, please contact Ewellix for support.

These operating instructions and the manual for the overall system, which contains the most important elements of these operating instructions, must always be available at the place of operation of the slides or the system.

It is not only the general safety advice listed here under “safety” which must be observed. Also pay attention to the additional safety advice in the other chapters of this manual and to existing national accident prevention regulations.

2.1 Hazard potential

The machine will not perform the intended function (fault), for various reasons, including:

Potential risks

The machine will not perform the intended function (fault) or can cause an accident or injury, for various reasons, including:

- Human mistakes
- Malfunction of safety devices
- Unauthorized personnel
- Variation of the processed material, or of the workpiece.
- Failure of one or more of its components.
- External effects (for example shock, vibration, electromagnetic magnetic fields).
- An error or defect in the design
- Failure of power supply
- Inability to gain control of the machine by the operator

⚠ DANGER

The CLSM linear module series has been designed and constructed in compliance with state-of-the-art technology. They are safe to use under the conditions tested by us. Nevertheless, they can pose potential hazards to the life and health of the operators as well as to the machine and other asset values and to efficient machine operation if:

- They are not mounted or operated by trained or at least instructed personnel, or,
- They are used incorrectly or for a purpose other than intended, or,
- The safety advice in the system manual is not observed.

⚠ DANGER

These in particular are the hazards:

- There is a risk of trapping, slicing or cutting fingers or the hand between the slide top and the end plates.
- During continuous operation, the motor and thus the surface can heat up, which creates a burn hazard when touching the parts.
- Further sources of danger are the strong attractive forces of the permanent magnets fitted in the secondary part, the resulting magnetic field and the risk of electric shocks when touching the motor contacts.

These hazards must be prevented through suitable protective devices within the final machine. There are warning labels on both end plates if the profile rail slide has bellows and on two outer magnets if there are no bellows. It is forbidden to remove or damage these labels. If you need new warning labels, please contact Ewellix.

2.2 Intended use

The device has been designated and built exclusively for its intended purpose as described in these instructions.

The device is only to be used to lift or transport loads.

It can be installed in industrial and construction technology applications.

- The CLSM linear module must only be used for positioning loads that do not give off emissions which could pose a danger to the axis and that do not overload the axis. The transport of people and animals is forbidden.
- The CLSM linear module have been designed for horizontal installation as a single axis or as a combination of axes such as cross tables or gantries. Where vertical installation is planned, please contact Ewellix.
- The CLSM linear module must not be used in outdoor, wet or explosive areas.
- The CLSM linear module have to be used within the temperature range of 0 to 55 °C.

WARNING

Risk from misuse

Any utilization of this device beyond its intended purpose may lead to potentially hazardous situations.

Therefore:

- Strictly adhere to all safety precautions and instructions in this operating manual.
- Do not allow this device to be subjected to weather conditions, strong UV rays, corrosive or explosive air media as well as other aggressive media.
- Do not modify, retool or change the structural design or individual components of the linear module.
- Never use the device outside of the technical application and operational limits described in this manual.

2.3 Essential performance

Essential performance is the performance necessary to achieve freedom from unacceptable risk. Unacceptable risk occurs when a product's failure will cause harm to the workers or the environment

Essential performance of the CLSM linear module is operation between the range of performance and environment data.



NOTE

Product specifications for each linear module are indicated in **11.0 Appendix**.

DANGER

Risk of injury and harmful results of failure of essential performance

The CLSM linear module must maintain essential performance in both operation and during the failure of any one component of the device.

2.4 Responsibility of the owner and processor

The device is designed for personal use and is also used in commercial applications by owners or processors.

The processor is the contracting partner of the reseller or the manufacturer. The processor installs the device in a complete system (application).

Any injury, damage or loss caused by violation of these instructions will be the responsibility of the owner or processor.

In addition to following the safety instructions in this manual, the owner or processor must do the following concerning the safety and accident prevention guidelines and environmental protection regulations applicable to the site of the system's installation:

- Inform themselves of applicable industrial safety regulations and use risk assessment to determine additional hazards that arise due to the specific working conditions prevailing at the site where the device is installed. The risk assessment must be implemented in the form of work instructions for device operation.
- Must confirm that the work instructions created for the system including the device satisfy current legal requirements and modify the instructions, if they don't.
- Clearly regulate and specify the responsibilities for installation, operation, maintenance, and cleaning the system.
- Ensure that all employees who deal with the device have read and understood this manual.
- Provide personnel with the required protective equipment.
- Must train personnel at regular intervals and inform personnel of the hazards.
- In addition, owner must ensure that the device is in adequate working condition. They must do the following:
 - Ensure that the maintenance intervals described in these instructions are complied with.
 - Have all safety devices inspected regularly for function and completeness

2.5 Authorized personnel

The CLSM linear module must only be installed, started up, operated and maintained by qualified personnel.

⚠ WARNING

Improper installation, operation and maintenance can result in serious injury, death or property damage. Use only qualified, trained personnel (as described below) who have read, understand and follow these instructions.

The operator of the CLSM linear module series must ensure that these operating instructions are available to the workers in charge of installation, start-up, operation and maintenance of the slides, and make sure that the manual is thoroughly studied and understood.

Only then may the machine be put into operation.

2.5.1 Qualifications

The following qualifications are specified for different areas of activity listed in the manual.

- **A trained person (Operator)**
Has been instructed by the customer in an orientation session on the assigned tasks and possible dangers in case of improper behavior.
- **Qualified personnel**
Based on their professional training, know-how and experience as well as knowledge of the applicable standards and regulations, these personnel are able to perform assigned work activities and to detect and avoid possible dangers on their own.

Only persons who are expected to perform their tasks reliably are permitted and personnel whose reaction capability is impaired, for example, through drugs alcohol or medication, are not permitted.

2.6 Modifications to the device

To avoid hazardous situations and to ensure optimal performance, do not make any changes or modifications to the device unless they have been specifically authorized by Ewellix.

2.6.1 Warning labels



The symbol to the right can be found on the linear module near the hot surface danger.

Hot surfaces on the linear module can cause burns and should not be touched.

Protection should be provided against accidental contact if necessary.

2.7 General safety advice

⚠ DANGER

It is imperative that the following notices are observed during installation, start-up, maintenance, operation and repair! Any installation and repair work to the CLSM linear module should only be carried out when the machine is at a standstill and de-energized. Prior to beginning the work, you must ensure that the intermediate circuit of the power output module is completely discharged and that unauthorized or unintended switching on of a supply voltage by third party is not possible. According to 2006/42/EC machine directive, the CLSM linear module is partly completed machinery. Operation of the axis is only permissible with suitable mechanical and electrical protective devices. These must comply with the laws and regulations of the respective country in which the CLSM module is operated.

The CLSM-150-L...A linear module is fitted with strong permanent magnets. People with cardiac pacemakers or other implants that must not be exposed to strong magnetic fields, must keep a safe distance of at least 1,5 m. This distance must be kept irrespective of the installation and operational condition of the axis as well as during transport and storage. Corresponding warning labels are fitted directly to the axis and must also be applied to the final machine clearly visibly by the operator when the axis has been installed.

Magnetizable data storage media may be destroyed or damaged by the strong magnetic fields. For such data carriers, keep a minimum distance of 200 mm.

Due to the high magnetic forces, be especially careful during installation of the axis into the final machine as well as during work near the axis when using iron-containing objects (for example, tools).

⚠ DANGER

The standard-type motor of CLSM linear module is commutated via an incremental encoder system. Depending on the type of amplifier used, there can be a short movement of the slide when switching on the axis.

The operator must ensure that this potential commutation movement will not damage the machine or endanger people.

- The standard version of the CLSM linear module is not fitted with a separate brake. In the event of voltage breakdown or failure of the measurement system, the slide may move into its end position uncontrolled. The CLSM linear module series is equipped with end position dampers. If these cannot be reached because the application dictates limited travel, the operator must ensure that other end position dampers are fitted to the final machine that can take over this function in the event of failure.
- For vertical applications of the axis, please contact Ewellix.
- When CLSM-150-L without bellows is used, the operator is obliged to protect the magnetic rail against contamination, in particular against iron-containing foreign particles. These can destroy the motor due to the small air gap between the primary and secondary part.

2.8 Electrical safety

**NOTE**

Declaration of EMC (Electro Magnetic Compatibility) of the linear motor for CLSM-150-L...A is provided, if needed.

**DANGER**

The plug and socket connections of motor and encoder must never be separated or connected under voltage! Disconnecting the motor plug is permissible only after switching off the power output module of the servo amplifier and discharging of the intermediate circuit down to below 40 V. The time for discharging of the intermediate circuit depends on the servo amplifier used and the connected load and can be gathered from the relevant documentation. As a rule, a discharging period of 5 minutes can be considered sufficient.

2.9 Disclaimer of liability

When the safety advice in this manual is not observed, this can endanger persons, the environment and machinery.

The manufacturer assumes no liability for unauthorized modifications to the CLSM Linear module., nor for improper installation, start-up, maintenance and repairs as well as unauthorized use or improper operation of the CLSM Linear module.

Only original replacement and expandable parts from Ewellix and SIEMENS are approved and should be used without exception.

The use of other parts may result in increased hazards.

3.0 Technical data

NOTE

The technical data (dimensions, weight, output, connection value etc.) can be found in the drawings and data sheets at the end of this manual (11.0 Appendix).

3.1 Operating conditions

Environment

Information Unit	Value	Unit
Temperature range	0...+55	°C
Relative atmospheric humidity, maximum (no build up of condensation)	95	%

3.2 Product label

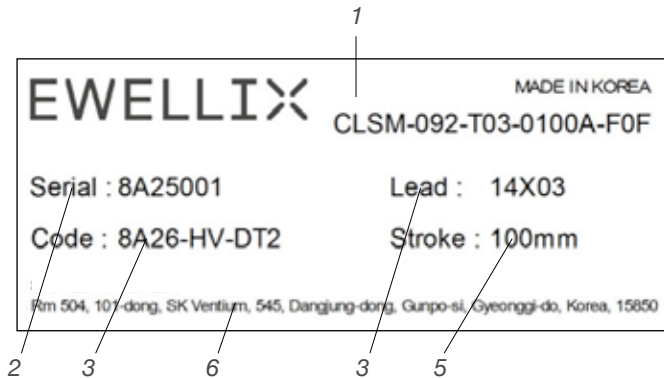

The Product label provides the following information

1. Identification of Type
2. Serial Number
3. Code Number
4. Address
5. Lead
6. Stroke

3.3 Safety sign labels attached on the device



WARNING
 The outside temperature of the module should not exceed 70 °C. Exceeding this temperature will decrease the life rating of the linear module as described in the performance diagram.

4.0 Structure and function

4.1 Brief description

The CLSM is a mechanical drive designed to work in factory automation or medical industry. The drive is used exclusively for the movement of the carriage.

The operating principles and structures are described in this section.

Ball screw type

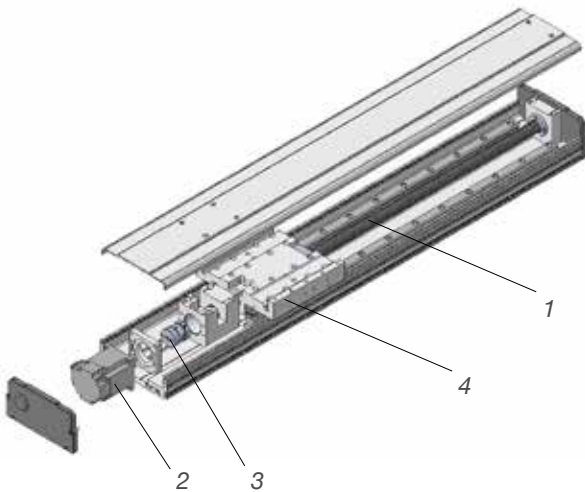

The figure above is CLSM-150-B...A. The ball screw (1) in the linear unit is powered by the motor (2). The coupling (3) is used to transfer power between the motor and the ball screw.

When ball screw rotates, the carriage (4) starts to run back and forth according to the direction of motor rotation.

CLSM-150-B...P, and CLSM-150-B...S have the same mechanism.

Linear motor type

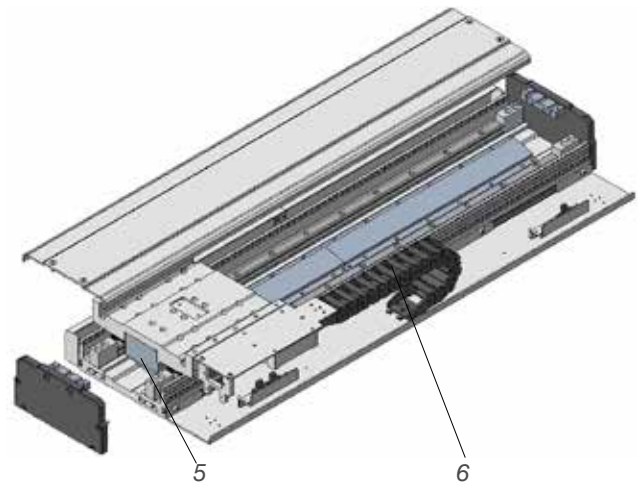

The figure above is CLSM-150-L...A. Unlike ball screw type of module, this module is powered by a linear motor mover (5). If the power is supplied through the cable (6), the linear motor mover is magnetized and can move the linear motor stator.

The carriage is attached to the linear motor mover, so it can move back and forth.

4.1.1 CLSM Linear module overview

CLSM-150-B...A

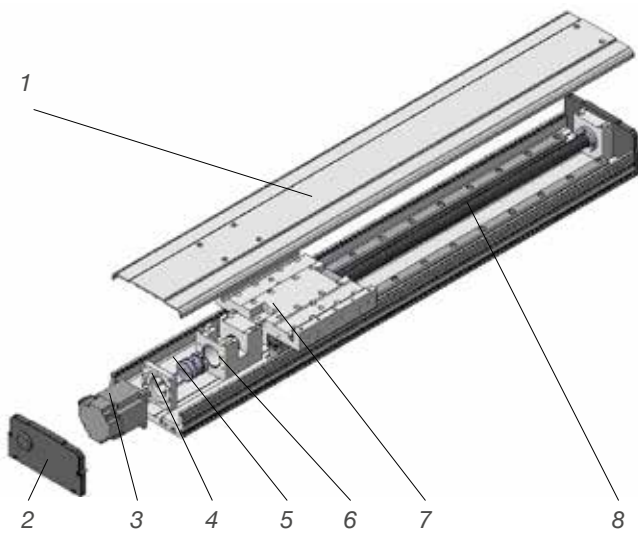

CLSM-150-B...A

1. Upper cover
2. End plate
3. Motor (option)
4. Motor adapter
5. Coupling
6. Coupling housing
7. Carriage
8. Ball screw

CLSM-150-B...P

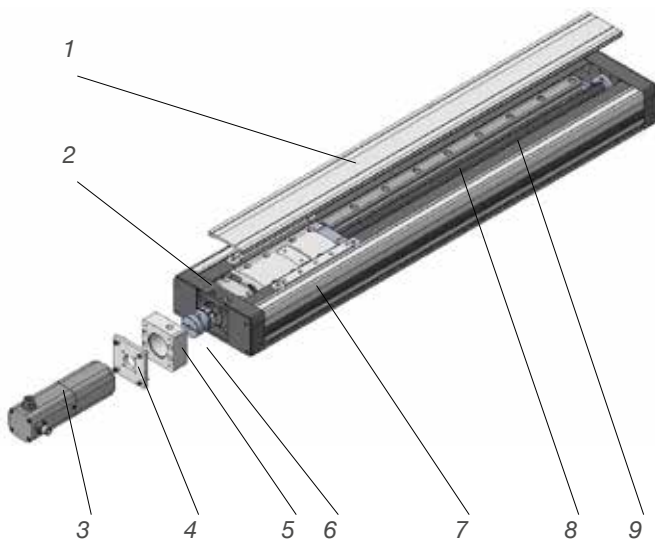

CLSM-150-B...P

1. Upper cover
2. View window
3. Motor (option)
4. Motor adapter
5. Coupling housing
6. Coupling
7. Carriage
8. Ball screw
9. PU strip

CLSM-150-L...A

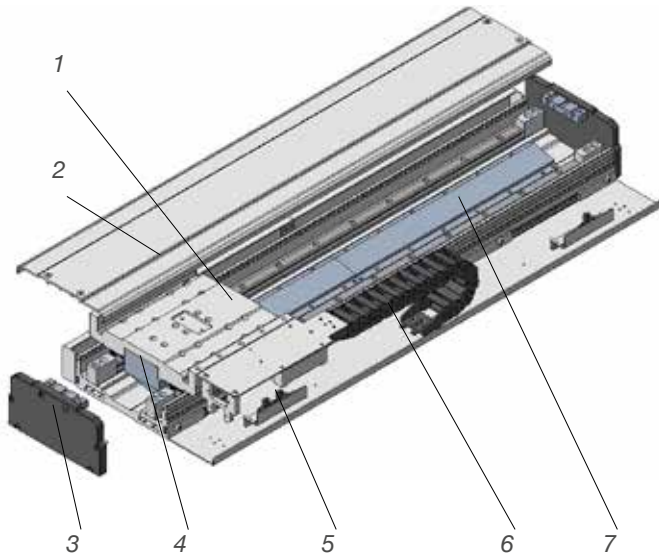

CLSM-150-L...A

1. Carriage
2. Upper cover
3. End plate
4. Linear motor mover
5. Sensor bracket and photosensor (Omron EE-SX674)
6. Cable and cable chain
7. Linear motor stator

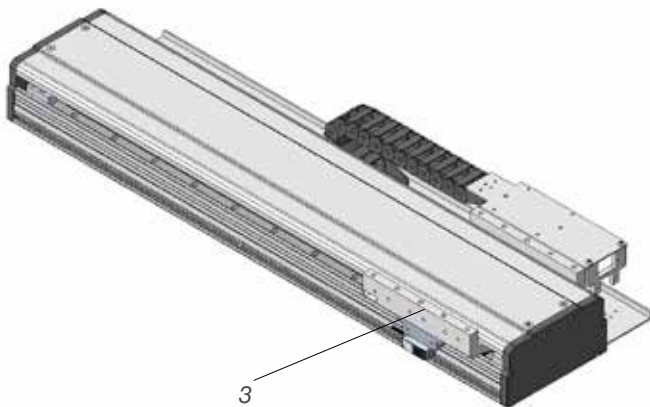

CLSM-150-L...A

3. Encoder (RSF Elektronik -MS15MK)

4.2 Direction of motor during operation

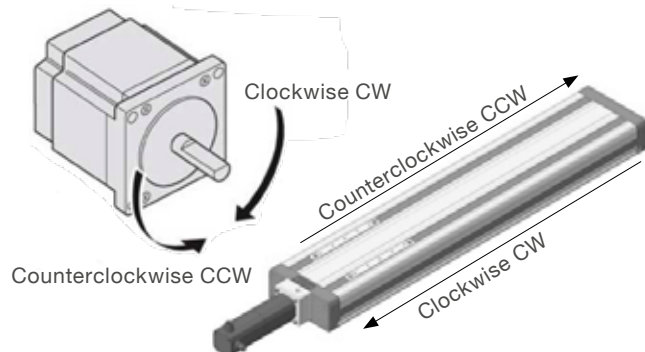

1. Clockwise CW: The carriage moves backward.
2. Counterclockwise CCW: The carriage moves forward.

4.3 Sensor mounting

Sensor can be mounted in the grooves on the CLSM 150 linear module.

Install the sensors: the sensors can be mounted into the grooves after disassembling the end plates and tightening the sensor brackets with fixing screws.



Note

The technical data (dimensions, weight, output, connection value etc.) can be found in the drawings and data sheets at the end of this manual (**11.0 Appendix**).

5.0 Delivery, Packaging and Storage

5.1 Safety information for transporting

- Avoid shocks during transport.
- Transport the CLSM linear module only with original packaging
- Always ensure that the transportation safety device is mounted
- Store only in dry, well-tempered areas
- Remove packaging just before mounting the module and save it in case you need to return it
- The CLSM linear module must only be lifted at the bottom part
- When lifting the CLSM linear module, always support the entire bottom. Otherwise a deflection can occur due to its own weight resulting in reduced accuracy
- Only use lifters and gadgets with sufficient load carrying capacity
- It's only allowed to remove the transportation safety device of the CLSM linear module after inserting the axis into the final machine and tightening at least 50% of the attachment screws of the bottom part

NOTICE

Proper transport is imperative to prevent significant material damage,

Therefore:

- Proceed carefully during the loading, unloading and delivery of the package items to its final destination and comply with the information shown on the packaging,
- Only remove the module from its packaging right before installation.
- Note storage requirements if the linear module needs to be returned to the manufacturer (**5.3 Returning module to the manufacturer**).

5.2 Delivery inspection

The CLSM linear module is delivered as one packaged unit in a box or on Pallets

Check the delivery for completeness and damage immediately upon receipt.

Check completeness of delivery:

- Unpack
- Check that all devices and options are contained in the package
- Check the products for damage, scratches and dents

Proceed as follows in conjunction with visible exterior transport damage:

- Do not accept delivery or do so only with reservations
- Record scope of damage on the transport document or on the bill of delivery of the shipping company
- Initiate complaint with shipping company



Note

Report any damage as soon as it has been recognized.

- Damage claims can only be asserted within the transporter's applicable complaint period.

5.3 Returning module to the manufacturer

Proceed as follows for the return transport:

1. Dismantle the device if necessary (**10.0 Dismantling**)
2. Pack device in its original packaging. Follow storage conditions (**5.5 Storage**)
3. Send to manufacturer. The address is listed on the back cover of this manual.

5.4 Packaging

For packaging

The individual packaged pieces have been packaged appropriately according to the expected transport conditions. Only environmentally friendly materials were used for the packaging.

The packaging is supposed to protect against corrosion and other damage until they are ready for installation. Therefore, do not destroy the packaging for possible return shipment to the manufacturer (**5.3 Returning module to the manufacturer**).

Example of packaging



When disposing of the packaging, please note and adhere to the following.

Note

Environmental damage due to incorrect disposal

Packaging material consists of valuable raw materials and in many cases they can be sensibly recycled and reused.

Therefore:

- Dispose of packaging material in an environmentally correct way
- Comply with locally applicable disposal regulations.

5.5 Storage

Pack the device in its original packaging for storage.

- Do not store outside
- Storage should be dry and dust-free
- Keep away from any aggressive media
- Protect from UV radiation
- Avoid mechanical vibrations
- Storage temperature: -20 to 40 °C
- Relative atmospheric humidity: max, 95% (no build up of condensation)
- To store longer than three months, check the general condition of all parts of the packaging on a monthly basis. If necessary, refresh or renew the conservation



Note

It is possible that there are notices on the packaging concerning storage which go beyond the requirements listed here. If so, follow those notices.

6.0 Installation

Authorized personnel

The installation and initial operation may only be conducted by qualified personnel.

⚠ WARNING

Risk of injury and material damage due to incorrect installation of the device.

Therefore:

- Devices may only be installed in accordance with their respective instructions.

6.1 Installation location

To determine the proper location for the module, adhere to the technical data (11.0 Appendix).

Install in a location where the module is not exposed to strong UV radiation or corrosive or explosive air media.

6.2 Inspections prior to initial operation

Performed by professional electrician.

Prior to the initial operation, a professional electrician must perform and document the following tests and readings:

- Check visual condition.
- Function check of operation features and safety features.

Note

See additional information concerning inspection and readings (8.0 Maintenance).

6.3 Installation

⚠ DANGER

Hazard of installation by unauthorized personnel
To prevent injury and damage to the property, installation has to be performed by trained personnel.

The CLSM linear module is attached to the application by fixing bolts on the bottom plate of the module.

Note

To check the dimensions of the drill hole of the linear module for fastening bolts, see the drawings in the data sheets (11.0 Appendix).

⚠ DANGER

Risk of incorrect installation

- Do not support the CLSM linear module by only part of the body. It should be installed to support the weight of the entire body and loads
- Make sure the fixing surface of the application is evenly flat



1. Assemble the motor onto the linear module if the product is not pre-mounted
2. Secure elements of the application in which the linear module will be installed
3. Secure the bottom plate using pins

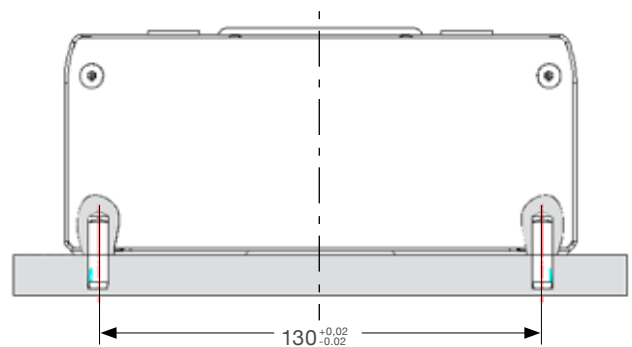

Pin specification	Value	Unit
Pin size	Ø 6 H7 pin Hole DP 10	mm

4. Bolt the linear module to the application

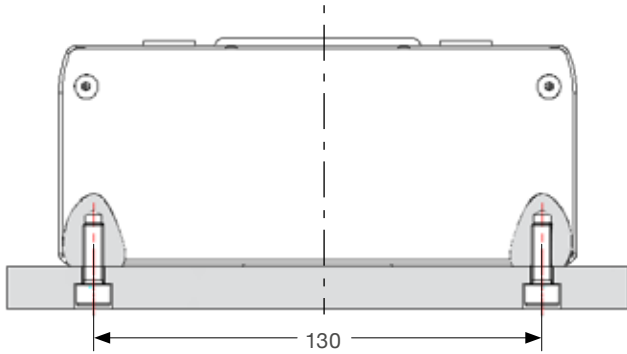

BOLT specification	Value	Unit
Bolt size	M6 Tap DP 12 (Hex SocketHead Cap)	mm

T SLOT

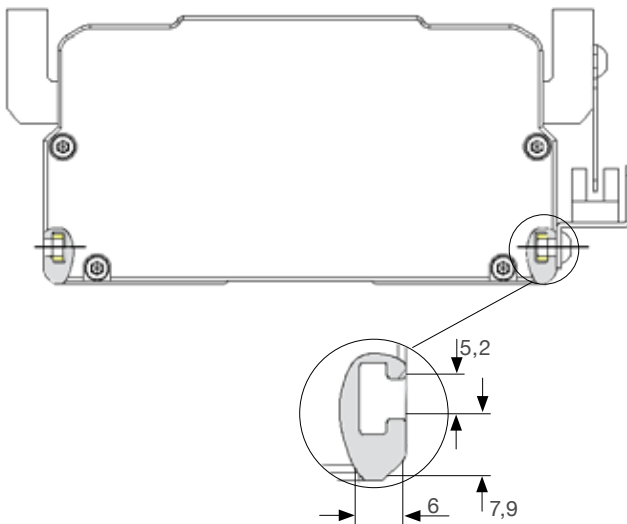

⚠ WARNING
Risk of injury and material damage due to impacts
 Ensure that the linear module is not impacted in its movement over the entire stroke area. Consider collision tests of the application.

⚠ WARNING
Risk of injury and material damage due to incorrect installation
 During installation, do not subject the linear module to sideimpact or to turning forces.

Affix prohibition and warning labels for the application onto the linear module, if necessary.

⚠ WARNING
Risk of injury and material damage due to loosening or removal of the screws on the device
 Removal or loosening of the screws on the linear unit may lead to injuries and material damage during operation. Therefore:
 • Never loosen or remove screws on the linear unit.

6.4 Turning device on and off

Note
 The device does not feature its own operating control elements. The operation takes place via separate operating elements.

7.0 Operation

7.1 Safety

DANGER

Risk of crushing

While moving onto solid objects, the force of the device may cause injuries.

Therefore:

- Ensure that there are no persons in the stroke area of the device while in operation
- Take note of maximum permissible operating parameters for device (**11.0 Appendix**)
- Do not touch elements connected to the device while the device is in operation

DANGER

If a part of the linear module fails (belt breaking, screw fracture, loss of input torque), the working mass will drop.

Therefore:

- Additional safety features must be in place to protect the workplace
- Where there is no input torque, and safe brake is loosened the carriage can be moved manually or by gravity, particularly for vertical application
- Check the drive regularly for signs or excessive wear (**8.2 Maintenance work**)

NOTICE

Material damage due to static and dynamic overload of the device.

Static and dynamic overload can damage the device and cause it to fail.

Therefore:

1. Adhere to maximum permissible operating parameters for the device (**11.0 Appendix**).
2. Never exceed nominal load.

WARNING

Burn hazard. Do not touch the surface of the device while operating.

WARNING

If liquids or dusts penetrate the linear module during operation, it can be damaged or will not operate properly. Keep liquid and dust away.

7.2 Normal operation

The CLSM linear module can be operated by a controller such as PC and PLC. The user gives a command to the program to send signals to the motor drive and operate the motor.

Before use, the device users may need to set the parameter like origin position, velocity and acceleration value.

Note

The device does not feature its own operating control elements. The operation takes place through separate operating element.

7.3 Action before use

Ensure that there are no persons or objects in the stroke area of the device.

Before using the device, make sure that the parts of the device and surrounding environment are clean and not explosive.

It should be used in a place free from water and dust.

NOTICE

Contamination of the devices can cause serious damage.

Therefore:

Clean dirty parts immediately after they become dirty (**8.2.1 Cleaning**).

7.4 Emergency disengagement

Note

The CLSM linear module has no emergency disengagement function.

Safety devices have to be available to protect persons and properties. In emergency situations, workers have to be able to push emergency stop switches to stop the device.

In case of an accident, stop the device immediately, call the medical Staff, and start emergency treatment.

7.5 Action after use

It is important to prepare and clean up the device for re-start. If the device is no longer used, power has to be disconnected from the device and system.

Always evaluate the checklist and record the log.

7.6 Installation instruction CLSM inline kit

7.6.1 Adapter kit

This adapter kit is to install a motor with an axially designed shaft (**7.6.2 Recommended motors**) to the CLSM linear module.

7.6.2 Recommended motors

In principle, all motors that are equipped with an axial shaft may be fitted with the CLSM linear module.

It is important that the rated power of the motors does not exceed the permitted value.

Ewellix recommends the following servo motors:

Performance overview of linear module - Lead & Ball screw

Linear unit	CLSM-92-T	CLSM-92-B	CLSM-150-B...A	CLSM-150-B...P	CLSM-150-B...S
Screw	Lead Screw 14x03	Ball Screw 12x05/10/20	Ball Screw 20x05/10/20	Ball Screw 20x05/10/20	Ball Screw 20x05/10/20
Motor	1FK7015 0.035 Nm 6000 r/min	1FK7022 0.85 Nm 6000 r/min	1F7034 1,60 Nm 6000 r/min	1FK7044 4,00 Nm 4500 r/min	-

Performance overview of linear module

Lead & Ball screw	Linear unit	CLSM-150-P...A
Screw	-	
Motor	1FK7015/1FK7022/1F7034/1FK7044	

Performance overview of linear module

Lead & Ball screw	CLSM-150-L...A
Screw	-
Motor	SGLFW – 3SA 120AP – 3SA 120AP

⚠ WARNING

For safe and correct operation and to prevent injury, do not disassemble the linear module.

7.6.3 Screws and tightening torques M_A

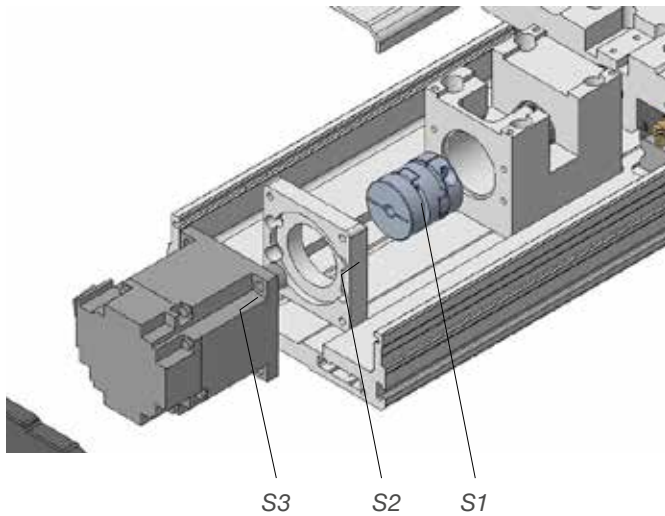

Screw size/ tightening torques

Linear unit	S1 (Coupling)		S2 (Motor adapter)		S3 (Motor)	
	Screw	Torque M_A	Screw	Torque M_A	Screw	Torque M_A
CLSM-92-T	M3x12	1.5 N·m	M4x20	4.0 N·m	M4x15	4.0 N·m
CLSM-92-B	M3x12	1.5 N·m	M4x20	4.0 N·m	M4x15	4.0 N·m
CLSM-150-B...A	M4x14	4.0 N·m	M4x15	4.0 N·m	M5x15	8.0 N·m
CLSM-150-B...P	M4x14	4.0 N·m	M4x15	4.0 N·m	M5x15	8.0 N·m
CLSM-150-B...S	-	-	-	-	-	-
CLSM-150-P... A	-	-	-	-	-	-
CLSM-150-L...A	-	-	-	-	-	-

Screw size/ tightening torques

Linear unit	Upper cover		End plate		Sensor bracket	
	Screw	Torque M_A	Screw	Torque M_A	Screw	Torque M_A
CLSM-92-T	M4x8	3.0 N·m	M4x20	4.0 N·m	-	-
CLSM-92-B	M4x8	3.0 N·m	M4x20	4.0 N·m	-	-
CLSM-150-B...A	M4x6	3.0 N·m	M4x20	4.0 N·m	M5x8	2.0 N·m
CLSM-150-B...P	M4x30	4.0 N·m	M4x20	4.0 N·m	M5x8	2.0 N·m
CLSM-150-B... S	-	-	-	-	-	-
CLSM-150-P... A	-	-	-	-	-	-

7.6.4 Coupling installation

The coupling hubs onto the motor shaft and the screw trunion of the linear unit.



Note

Do not tighten the screws of the coupling before aligning the coupling hubs.

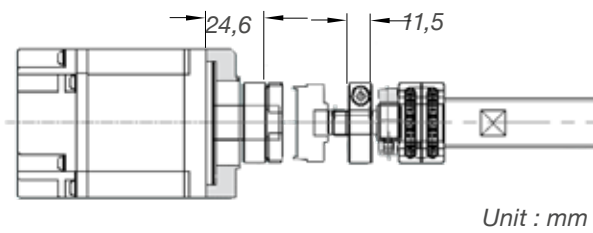

Note

Tighten the screws to the torque specified in the table above.

8.0 Maintenance

Personnel

- Daily maintenance work described herein can be performed by the Operator.
- Some maintenance tasks should only be performed by specially trained, qualified personnel employed by the product owner, or exclusively by personnel of the manufacturer; specific reference as to who should perform the maintenance will be made in each case in the description of the respective maintenance task
- Only professional electricians should perform work on electrical equipment

8.1 Maintenance plan

Maintenance tasks that are required for optimal and trouble-free operation are described in this section.

If increased wear is detected during regular inspections, shorten the required maintenance intervals according to the actual indication of wear.

CLSM linear module maintenance plan

Interval	Maintenance work	To be carried out by
Daily	Check the linear module for visible damage	Operator
	Clean off dust and dirt if necessary	Operator
Monthly	Check tight fit of the parts and options, correct if necessary	Qualified personnel
	Check connection for tight fit	
Annually	Check labels and warning notices for legibility and Replace if necessary	Qualified personnel
Semi-annually	Check options for visible damage	Qualified personnel

NOTICE

If the linear module is used outside of the environment conditions specified earlier in this manual, check such components once a month for any changes such as oxidation or sedimentation.

8.2 Maintenance work

8.2.1 Cleaning

Cleaning is to be performed by operator:

- Clean the surface of the linear module and the place in which the module is used
- Inspect and wipe out leaked grease
- Make sure there is no liquid around the device
- Check and remove any dust or foreign materials from the module.

NOTICE

Damage due to incorrect cleaning

- Do not use any aggressive cleaning agents. Water used for cleaning, including chemical additives, must be pH-neutral
- Liquids must not touch the module during operation
- Only use the auxiliary materials
- No steam jets or pressure washers may be used for cleaning
- Other cleaning agents or cleaning devices may only be utilized with the Ewellix's approval



Note

Clean dirty parts with a damp cloth that does not cause rust.

8.2.2 Check of visual condition

To be performed by qualified personnel.

Separate the device from the power supply.

Check the following structural components for visual external

CLSM-150-B...A

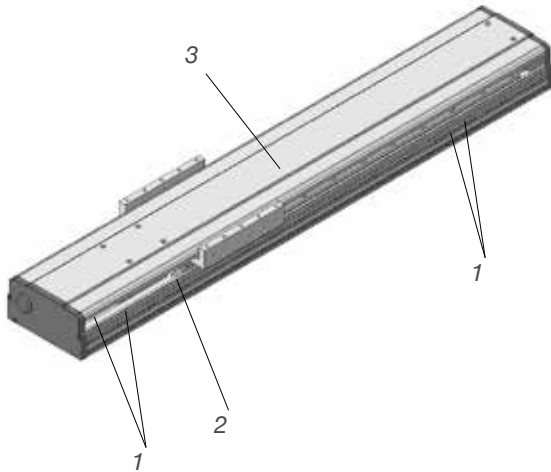

1. Check the end plates for cracks and gaps.
2. Check the profile for cracks, gaps and broken pieces.
3. Check the upper cover and for scratches and indentations.

Notify processor or linear module manufacturing in case of damage. If there is no damage and the processor / manufacturer has not communicated any concerns, reconnect the device to the power supply.

CLSM-150-B...A

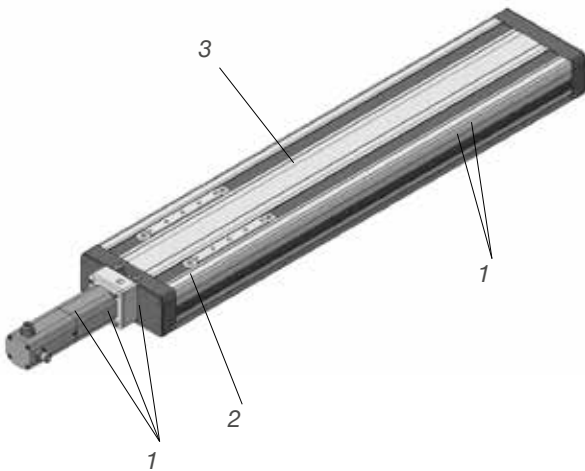

1. Check the end plates, motor adapter and coupling housing for the assembled state, cracks and gaps.
2. Check the profile for cracks, gaps and broken pieces.
3. Check the upper cover and for scratches and indentations.

Notify processor or linear module manufacturing in case of damage. If there is no damage and the processor / manufacturer has not communicated any concerns, reconnect the device to the power supply.

CLSM-150-B...A

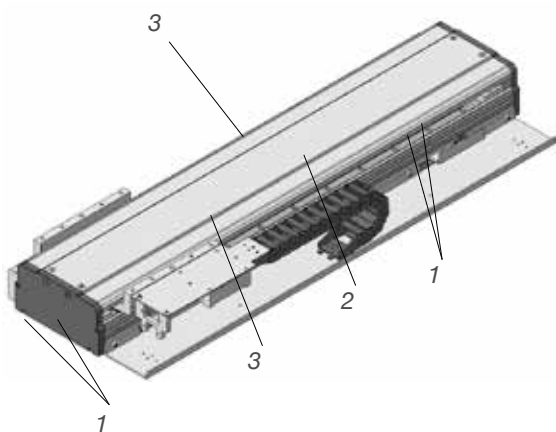

1. Check end plates for cracks and gaps.
2. Check the profile for cracks, gaps and broken pieces.
3. Check the upper cover and the cableveyor for scratches and indentations.

Notify processor or linear module manufacturing in case of damage. If there is no damage and the processor / manufacturer has not communicated any concerns, reconnect the device to the power supply.

8.3 Measures after maintenance completed

Upon completion of the maintenance work, the following steps have to be performed prior to restarting the device.

1. Check all screw connections for a tight fit
2. Ensure that all used tools, materials and other equipment have been removed from the work area
3. Clean work area and remove potential spills such as liquids and processing material
4. Ensure that all safety features of the system work without a problem
5. Check functions
6. Document completion of the inspections in the service log

8.4 Maintenance checks

During each service interval, the following measurement/check needs to be done:

Inspection and management tips

Maintenance tips			
Part	Method of inspection	Confirmation (check) contents	Interval
LM Guide	Visual confirmation	Appropriate amount of grease No foreign substance	Quarterly
Ball screw	Visual confirmation	Appropriate amount of grease No foreign substance	Quarterly
Coupling	Visual confirmation	Slip during rotation Coupling clamp bolt tightening	Quarterly

⚠ WARNING

Crush hazard

- Do not operate the system when the cover or a component of the module is removed.

8.4.1 Grease lubrication

The lubrication of the ball screw and the LM Block must be considered in quantity and quality. See table below.

Grease quantity

Maintenance tips			
Size	Carriage type A, U, R cm ²	LA, LU, LR	SA, SU
–			
15	0,4	–	0,3
20	0,7	0,9	0,6
25	1,4	1,8	1,1
30	2,2	2,9	1,8
35	2,2	2,9	1,8
45	4,7	6,1	–

Grease Types

A selection of Ewellix rolling bearing greases

Properties	Lubricant (designation)	
	LGEP 2	LGMT
Thickener	Li	Li
Base oil	Mineral oil	Mineral oil
Operating temperature, °C (steady state)	-20 up to +110	-30 up to +120
Kinematic viscosity of base oil	200	110
Consistency class (acc. to NLGI)	2	2
Temperature range/ Application range	EP grease	normal

Lubrication intervals

Size	Lubrication intervals	
	Under normal operating condition, v Fm ≤ 0.15 C km	≤ 1m/s travel under load Fm ≤ 0.3
–		
15	5 000	1 200
20	10 000	1 200
25	10 000	2 400
30	10 000	2 400
35	10 000	2 400
45	10 000	2 400

9.0 Malfunctions

The following chapter describes potential causes for malfunctions and the work that is necessary to restore operation.

In the event of more frequent malfunctions, shorten the maintenance intervals.

Contact the manufacturer concerning malfunctions which are not solved by the repair suggestions in **9.1 Malfunction table**; see service address on www.ewellix.com.

Personnel

- Unless indicated otherwise, the work described herein to solve malfunctions may be performed by the operator
- Some work may only be carried out by qualified personnel, which is specifically indicated in the description of the individual malfunction
- Work on the electric system may only be performed by professional electricians

DANGER

Risk of injury and material damage due to incorrect repair of malfunctions

The CLSM linear module is not designed to be repaired by the customer in most situations. Incorrect repair of a malfunction may lead to personal injury or material damage.

Therefore:

- Never loosen the screws on the linear module or try to open
- In the event of a malfunction that cannot be fixed by adhering to the suggestions in the table below, dismantle the device and send it to the manufacturer for repair (**5.0 Delivery, packaging and storage**)

Actions during malfunctions

1. In the event of a malfunction that may present an immediate danger to persons or assets, turn off the drive
2. Determine cause of malfunction
3. Depending on the type of a malfunction, have it repaired by the operator or qualified personnel (**9.1 Malfunction table**)
4. Inform responsible party on-site concerning malfunction.

**NOTE**

The following malfunction table provides information as to who is authorized to perform the repair and how it is to be performed.

9.1 Malfunction table

Problems and solving method			
Malfunction	Possible cause	Repair malfunction	To be carried out by
Linear module doesn't move	Obstacle in the stroke area of the linear module	Remove all obstacles in the stroke area	Operator
	Incorrect load	Measure static and dynamic load and compare with information concerning the product label. If the load capacity is exceeded, check the nominal load and install a stronger module if necessary	Qualified personnel
	Lifespan of the device is exceeded	See performance diagram in the brochure	Qualified personnel
	Linear module cannot be set in motion by any of the above listed measures	Exchange device	Qualified personnel
Linear module cannot be lifted	Obstacles in the stroke area of the linear module	Remove all obstacles in the stroke area	Operator
	Incorrect load	Remove all loads that are on the elements	Operator
	Defective motor, gear or screw nut	Exchange device	Qualified personnel
Significant reduced speed	Obstacles in the stroke area of the linear module	Remove all obstacles in the stroke area	Operator
	Incorrect load	Remove all loads that are on the elements	Operator
	Defective motor, gear or screw nut	Exchange device	Qualified personnel
Significant increase of noises	Obstacles in the stroke area of the linear module	Remove all obstacles in the stroke area	Operator
	Incorrect load	Remove all loads that are on the elements	Operator
	Defective motor, gear or screw nut	Exchange device	Qualified personnel

9.2 Start of operation after fixing malfunction

After the malfunction has been fixed, perform the steps from the installation chapter prior to restart.

10.0 Dismantling

Personnel

- The dismantling may only be carried out by qualified personnel
- Work on the electric system may only be performed by professional electricians.

⚠ WARNING

Risk of injury due to incorrect dismantling

Stored residual power, sharp-edged components, pins and corners on the individual components or at the required tools can cause serious injuries.

Therefore:

- Ensure there is ample space for dismantling prior to starting with the work. Use caution when working with open, sharp-edged structural components
- Ensure order and cleanliness at the dismantling site! Loosely stacked structural components or tools on the floor may present a source for accidents
- Dismantle structural components professionally pursuant to applicable local regulations
- Secure structural components in a way so they will not be able to fall or tip over
- Contact the manufacturer if you have any questions or concerns

10.1 Dismantling of the CLSM linear module

1. Secure elements of the application in such a fashion that no loads can impact the parts
2. Loosen and remove fastening bolts
3. Separate the linear module from application elements.
4. Clean device
5. Carefully package for shipment to the manufacturer
6. For disposal, disassemble device according to applicable local occupational health and environmental regulations

10.2 Disposal

To the extent that no take-back or disposal agreement has been put in place, disassembled components should be recycled.

- Dispose of metals and plastic components at an appropriate recycling center
- Sort remaining components based on the respective material and dispose of according to applicable local occupational health and environment regulations.

NOTICE

Damage can be caused to the environment due to incorrect disposal

Electric waste, electronic components, lubricants and other additives are subject to special waste treatment regulations and may only be disposed of by approved specialized companies.

The local municipal authorities or specialized waste management companies can provide information concerning environmentally appropriate disposal.

11.0 Appendix

Technical data sheets

IL-06018-1-EN-June 2021 Linear modules and systems

For further technical information please contact Ewellix.



ewellix.com

© Ewellix

All contents of this publication are the property of Ewellix, and may not be reproduced or given to third parties (even extracts) without permission. Although great care has been taken in the production of this catalog, Ewellix does not take any responsibility for damage or other loss resulting from omissions or typographical errors. The photo may differ slightly in appearance from the actual product. Due to continuous improvements being made in our products, the product's appearance and specifications are subject to change without notice.

PUB NUM TC-08040-EN-September 2020