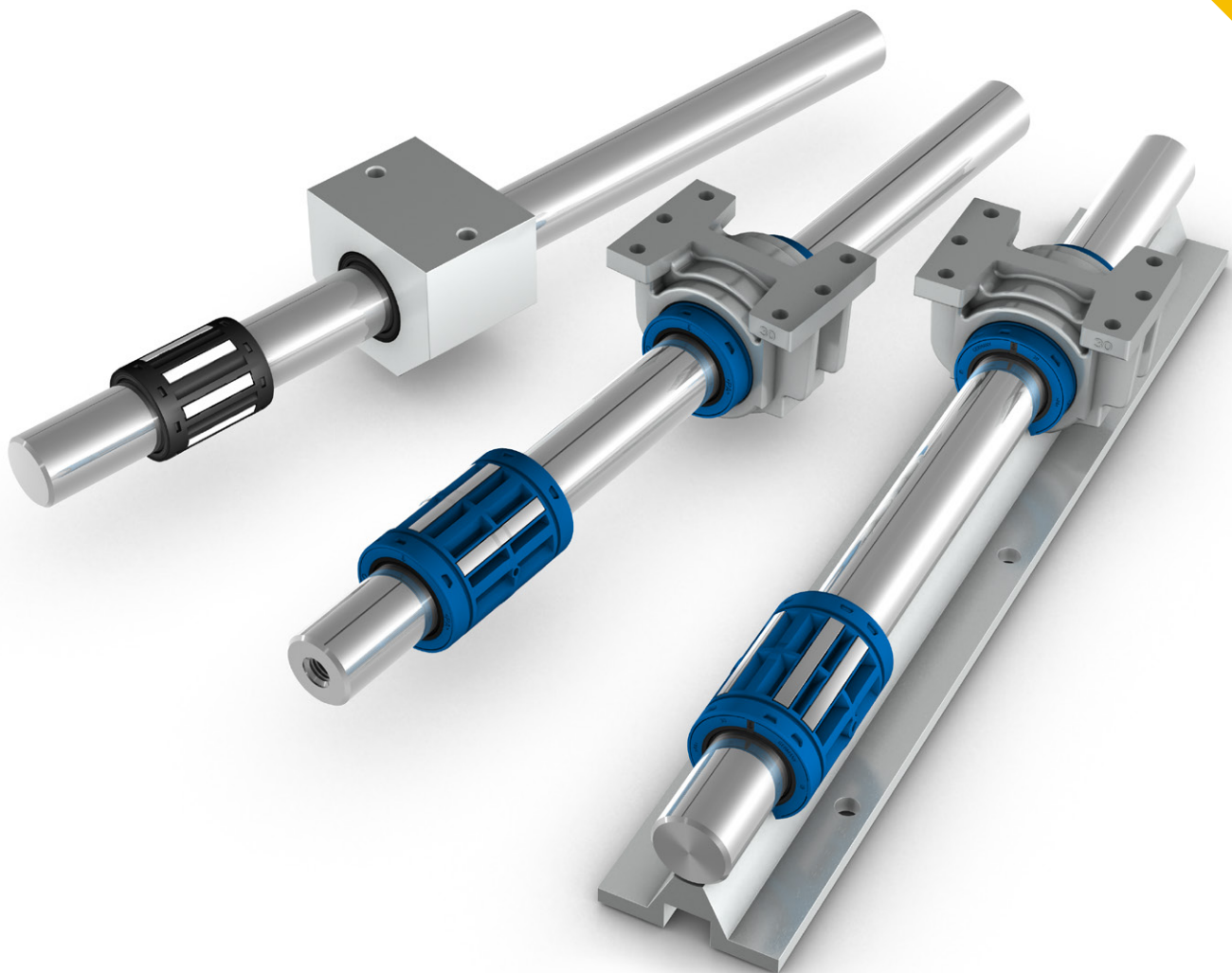


# EWELLIX

A Schaeffler Company

## Linear bearings, units and shafts catalogue





# Contents

<b>1. Introduction .....</b>	<b>4</b>
1.1 Product introduction .....	5
1.1.1 Product function .....	5
1.1.2 Design and materials .....	6
1.1.3 Range description .....	7
1.2 Features and benefits .....	10
1.2.1 Compact range .....	10
1.2.2 Standard range .....	12
1.3 Range overview .....	14
1.3.1 Overview assortment .....	14
1.3.2 Overview of range and availability .....	20
1.4 Applications of linear bearings .....	24
<b>2. Selection guide .....</b>	<b>28</b>
2.1 Technical data .....	29
2.1.1 Permissible operating conditions .....	29
2.1.2 Accuracy .....	30
2.1.3 Rigidity .....	34
2.1.4 Friction .....	36
2.2 Dimensioning of linear bearings .....	37
2.2.1 Calculation bases .....	37
2.2.2 Calculation of bearing loads .....	40
2.2.3 Factors of influence .....	44
2.2.4 Elaborated equations for the static safety factor and for the rating life .....	52
2.2.5 Calculation example .....	53
2.3 Technical data of plain bearings .....	58
2.3.1 Range of applications .....	58
2.3.2 Basic technical principles .....	58
2.3.3 Service life .....	58
2.3.4 "pv" load/speed relation .....	59
2.3.5 Load ratings .....	59
2.3.6 Friction .....	59
2.3.7 Tolerances .....	60
2.3.8 Lubrication .....	61
2.3.9 Shafts for plain bearings .....	61
2.3.10 Housing tolerances and mounting of plain bearings .....	61
2.4 Legend .....	62
<b>3. Product range .....</b>	<b>64</b>
3.1 Compact linear bearings .....	65
3.1.1 Compact linear ball bearings - LBBR .....	66
3.1.2 Compact linear plain bearings - LPBR .....	68
3.1.3 External shaft seals for compact bearings .....	69
3.2 Compact linear units .....	70
3.2.1 Compact linear units - LUHR .....	72
3.2.2 Compact linear units - LUJR .....	74
3.2.3 Compact tandem units - LTBR .....	76
3.2.4 Compact duo units - LTDR .....	78
3.2.5 Compact quadro units - LQBR .....	80
3.3 Standard linear ball bearings .....	82
3.3.1 Standard linear ball bearings - LBCR .....	84
3.3.2 Standard linear ball bearings - LBCD .....	86
3.3.3 Standard linear ball bearings - LBCT .....	88
3.3.4 Standard linear ball bearings - LBCF .....	90
3.3.5 Standard linear ball bearings - LBHT .....	92
3.3.6 Standard linear plain bearings - LPAR/LPAT .....	94
3.3.7 Grease fittings - VN-LHC .....	96
3.4 Standard linear units .....	97
3.4.1 Standard linear units - LUCR/LUCD .....	100
3.4.2 Standard linear units - LUCS/LUCE .....	102
3.4.3 Standard linear units - LUCT/LUCF .....	104
3.4.4 Standard linear units - LUCT BH .....	106
3.4.5 Standard linear units - LUNR/LUND .....	108
3.4.6 Standard linear units - LUNS/LUNE .....	110
3.4.7 Standard linear units - LUNT/LUNF .....	112
3.4.8 Standard flanged units - LVCR/LVCD .....	114
3.4.9 Standard tandem units - LTCR/LTCD .....	116
3.4.10 Standard tandem units - LTCT/LTCF .....	118
3.4.11 Standard quadro units - LQCR/LQCD .....	120
3.4.12 Standard quadro units - LQCT/LQCF .....	122
3.5 Standard housings .....	124
3.5.1 Standard housings - LHCR/LHCS .....	125
3.5.2 Standard housings - LHCT .....	126
3.6 Shaft blocks and shaft supports .....	127
3.6.1 Shaft blocks - LSCS .....	128
3.6.2 Compact shaft blocks - LSHS .....	129
3.6.3 Standard shaft blocks - LSNS .....	130
3.6.4 Compact tandem shaft blocks - LEBS .....	131
3.6.5 Standard tandem shaft blocks - LEAS .....	132
3.6.6 Standard shaft supports - LRCB/LRCC .....	133
3.7 Precision shafts .....	134
3.7.1 Shaft types and material .....	134
3.7.2 Shaft hardness and depth .....	135
3.7.3 Shaft corrosion resistance and protection .....	135
3.7.4 Precision shaft length .....	135
3.7.5 Technical data of precision shafts .....	136
3.7.6 Tolerances of precision shafts .....	137
3.7.7 Machined precision shafts .....	138
3.8 Linear slides .....	141
3.8.1 Linear slides - LZBU A .....	142
3.8.2 Linear slides - LZBU B .....	144
3.8.3 Linear slides - LZAU .....	146
<b>4. Mounting, operation and maintenance manual .....</b>	<b>148</b>
4.1 Design rules .....	149
4.1.1 How to use linear bearings .....	149
4.1.2 Housing design .....	149
4.1.3 Bearing fixation .....	150
4.1.4 Axial location .....	154
4.1.5 Sealing .....	155
4.1.6 Requirements on precision shafts .....	155
4.1.7 Mounting surfaces and shaft alignment .....	156
4.2 Mounting of linear bearings .....	157
4.2.1 Preparation .....	157
4.2.2 Mounting .....	157
4.2.3 Mounting of linear plain bearings .....	158
4.2.4 Adjustment of operating clearance .....	158
4.2.5 Grease lubrication .....	159
4.2.6 Delivery condition from factory .....	160
4.2.7 Initial lubrication .....	160
4.2.8 Relubrication .....	160
4.3 Maintenance .....	161
4.3.1 Preventative maintenance .....	161
4.3.2 Repairs .....	161
4.3.3 Shipping and storage .....	161
<b>5. Ordering key .....</b>	<b>162</b>
<b>6. Customer specification sheet .....</b>	<b>166</b>

# The heritage of innovation

Ewellix is a global innovator and manufacturer of linear motion and actuation solutions. Our state-of-the-art linear solutions are designed to increase machine performance, maximise uptime, reduce maintenance, improve safety and save energy. We engineer solutions for assembly automation, medical equipment, mobile machinery, distribution and a wide range of other industrial applications.

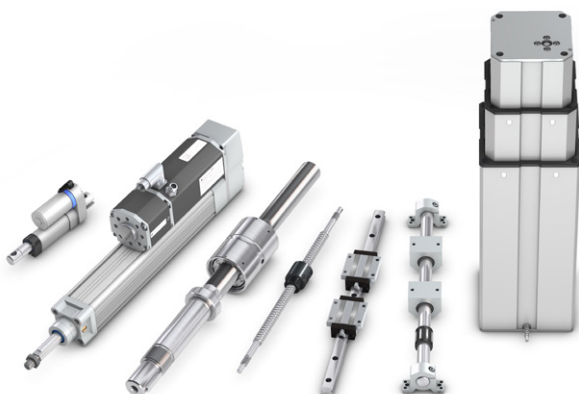
## Technology leadership

We earned our reputation through decades of engineering excellence. Our journey began over 50 years ago as part of the SKF Group, a leading global technology provider. Our history provided us with the expertise to continuously develop new technologies and use them to create cutting edge products that offer our customers a competitive advantage.

In 2019, we became independent and changed our name to Ewellix. We are proud of our heritage. This gives us a unique foundation on which to build an agile business with engineering excellence and innovation as our core strengths.

## Global presence and local support

With our global presence, we are uniquely positioned to deliver standard components and custom-engineered solutions, with full technical and applications support around the world. Our skilled engineers provide total life-cycle support, helping to optimise the design, operation and maintenance of equipment thus improving productivity and reliability while reducing costs. At Ewellix, we don't just provide products; we engineer integrated solutions that help customers realise their ambitions.



## Schaeffler Group – We pioneer motion

Ewellix is since 2023 owned by the Schaeffler Group.

As a leading global supplier to the automotive and industrial sectors, the Schaeffler Group has been driving forward groundbreaking inventions and developments in the fields of motion and mobility for over 75 years.

With innovative technologies, products, and services for electric mobility, CO<sub>2</sub>-efficient drives, Industry 4.0, digitalization, and renewable energies, the company is a reliable partner for making motion and mobility more efficient, intelligent, and sustainable.

Schaeffler manufactures high-precision components and systems for powertrain and chassis applications as well as rolling and plain bearing solutions for a large number of industrial applications.



# Trusted engineering expertise

Our industry is in motion; pushing towards solutions that reduce environmental impact and leverage new technology. We provide technical and manufacturing expertise to overcome our customers' challenges.

## Engineering for the future

We work in a **wide range of industries**, where our solutions provide key functionality for business critical applications.

For the **medical industry**, we provide precision components for use in core medical equipment.

Our unparalleled understanding of **assembly automation** systems is based on decades of research into advanced automation components and techniques.

Our deep knowledge of **mobile machinery** provides powerful and reliable electromechanical solutions for the harshest conditions. In an **industrial distribution** setting, we supply linear expertise to our partners, empowering them to serve customers with greater efficiency.

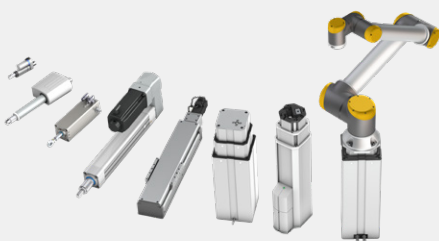
## We offer excellence

We have a **unique understanding of linear equipment** and how it's integrated in customers' applications to provide the best performance and machine efficiency.

**We assist our customers** by creating equipment that runs faster, longer and that is safe and sustainable.

We provide a wide variety of **linear motion components** and **electromechanical actuators** for equipping any automation application, thus helping our customers **increase productivity, reduce their footprint, energy use and maintenance.**

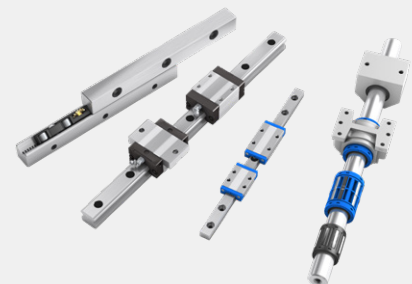
### Actuation systems



### Ball and roller screws

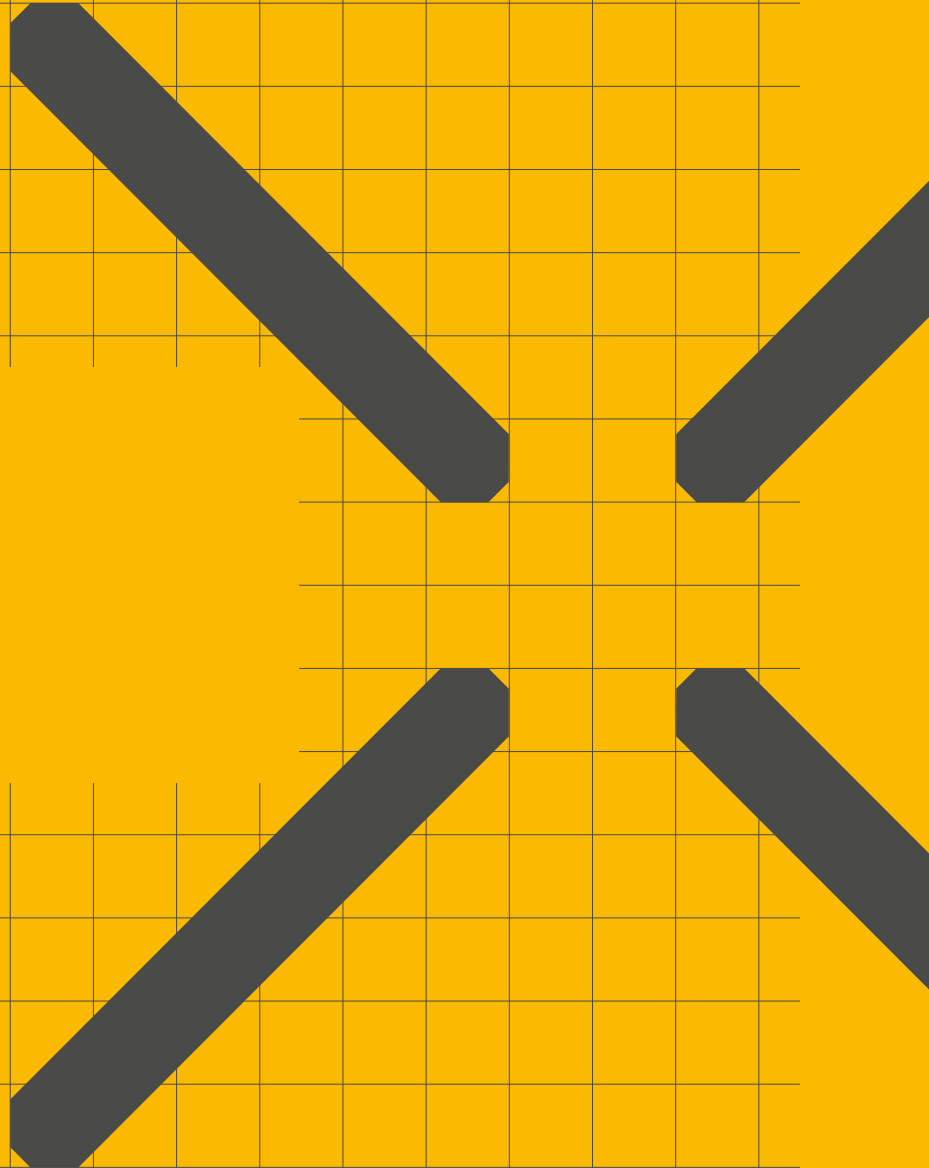


### Linear guides and systems



1

# Introduction



# 1.1 Product introduction

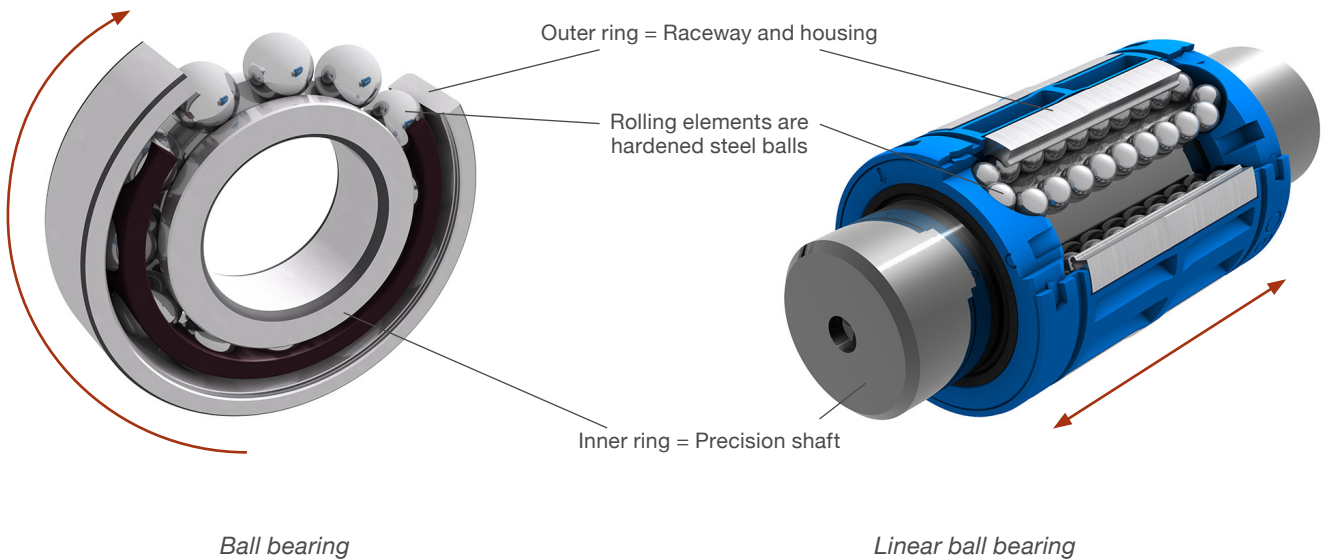
The Ewellix linear ball bearing assortment is widely used in a variety of economic and easy to implement linear guide systems. Nearly every application can be realised by the use of different bearing sizes and the huge range of units together with shafts and shaft blocks. The flexibility in combinations of the assortment makes it easy to find the right linear guide solution to support productivity. With this highly standardised range, implementation is quick as most components are available from stock.

## 1.1.1 Product function

Linear ball bearings translate rolling motion into linear motion. Like in a normal ball bearing, the rolling elements allow nearly frictionless linear movements even under load. For that function, the linear ball bearing needs a precision shaft (inner ring), several ball recirculation systems, and raceways to transmit the force into the housing. The ball

recirculation system, in principle, allows unlimited stroke of the linear bearings along the precision shaft.

Every component has to be very precise and must be made of hardened steel to reach solid long-term functionality of the linear guide. To build up a linear slide system, normally four linear ball bearings or units with two shafts and four shafts blocks are needed.



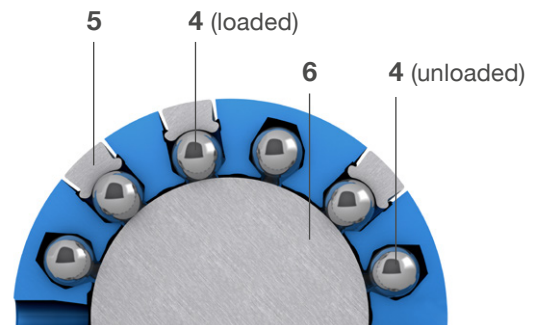
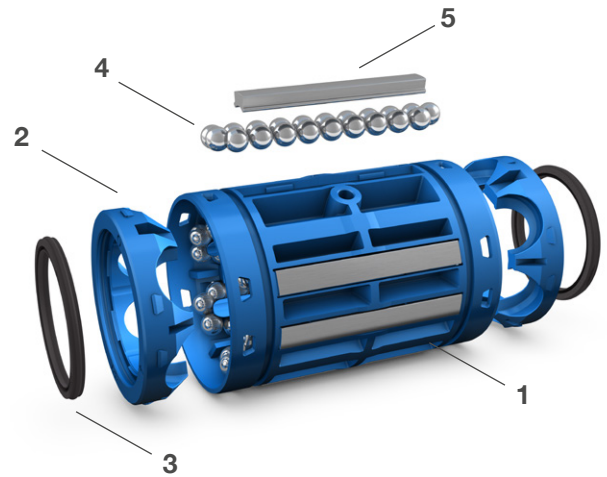
## 1.1.2 Design and materials

Linear ball bearings from Ewellix are designed for unlimited stroke applications. They consist of a plastic cage that contains the guiding elements, which are raceway plates and balls. Depending on the range and the size, linear bearings have different numbers of ball recirculations. Under the raceway plates, the steel balls are in the loaded zone. At the end of the raceway, the balls move into the unloaded zone and get circulated via the recirculation cap. When passing the opposite recirculation cap, they are moving back into the loaded zone. During motion, only the friction between the steel balls must be considered, therefore nearly frictionless linear motion is possible.

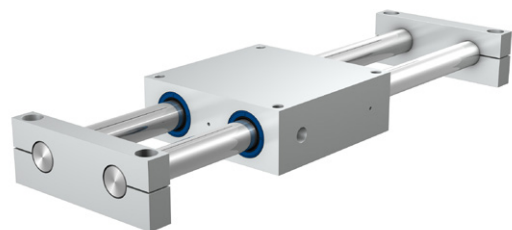
The bearing cage contains the ball rows with an equivalent number of raceway plates and at both ends recirculation caps. These caps can be flexibly equipped with double lip seals or with non-contacting shields. The low friction double lip seals keep the grease inside the bearings while moving the contamination safely away from the shaft. Besides the standard bearing steel material for rolling elements and raceway plates, all linear ball bearings can be manufactured as a stainless steel variant with special alloy stainless steel material.

### Material specifications

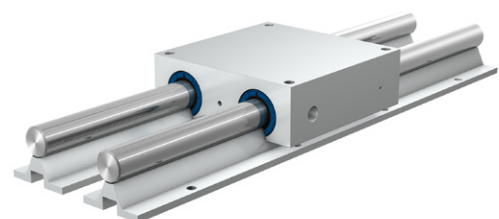
1. Linear bearing cage, plastic
2. Ball recirculation cap, plastic
3. Double lip seal, elastomer or shield, plastic
4. Steel balls (hardened), bearing steel
5. Raceway plates (hardened), bearing steel
6. Precision shaft, bearing steel



A typical linear slide arrangement consists of four linear bearings located in a housing and suitable shafts with shaft blocks or supports. The closed linear bearing and unit design is more economic and easier to install. It's mostly used for shorter linear strokes and less load where the impact of shaft bending is limited. For longer shaft length or higher load, the open design ball bearing with supported shafts is a better solution. The linear slides shown on this page visualise the closed and open design variants.



Quadro slide closed design



Quadro slide open design



### 1.1.3 Range description

Two different ranges are available, the compact one and the standard one, where both are using the same shaft dimensions. The compact one has a shorter length and diameter for best fit into applications with limited space. The compact range is in line with ISO 10285, series 1. The standard one is optimised for higher load rating using more space. It also includes the open design bearings for supported shaft solutions and is in line with ISO 10285, series 3. For the open types, a specific sub-series is made for heavy loads. For applications where a linear ball bearing is not suitable, each range offers interchangeable linear plain bearings for most sizes.

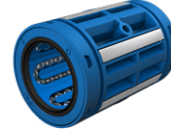
The dimensional difference between the compact and the standard range bearings can be seen in the below comparison where bearings with identical shaft diameter are shown. The compact ones are significantly smaller in length and outside diameter, where the standard ones are equipped with more performance (↳ **fig. 1**).

#### Linear bearing range

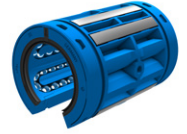
**LBBR**  
Compact bearing



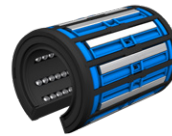
**LBCR**  
Standard bearing



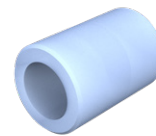
**LBCT**  
Standard bearing open design



**LBHT**  
Standard heavy duty bearing open design



**LPBR**  
Compact plain bearing



**LPAR**  
Standard plain bearing

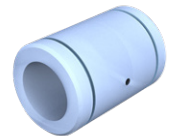
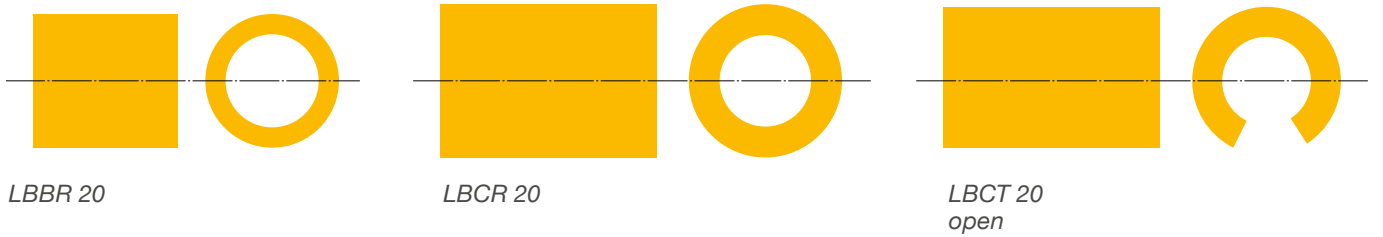


Fig. 1

#### Dimensional difference between the compact and standard range

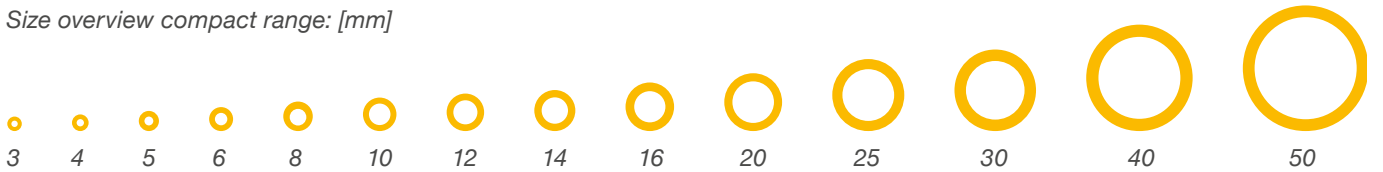


Each range is specifically available in shaft diameter sizes which are common for use in the market. The compact ones are more for the miniaturisation market going down to the

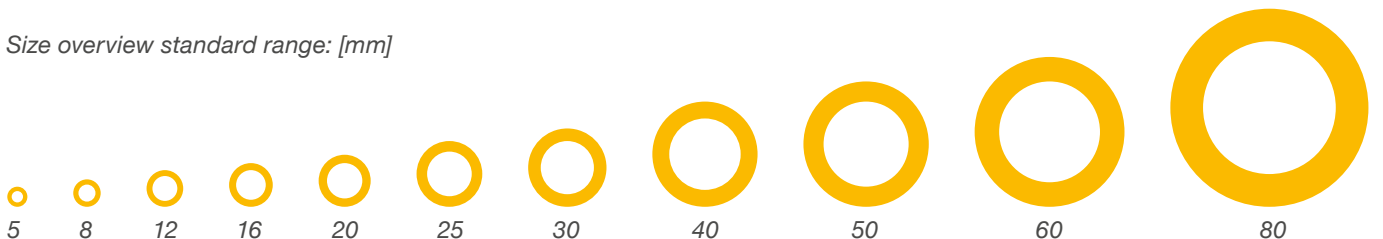
size of 3 mm. The standard ones can be used for up to 80 mm shaft size for very heavy loads (↳ **fig. 2**).

Fig. 2

#### Size overview compact range: [mm]



#### Size overview standard range: [mm]



Single linear ball bearings from Ewellix are easy to integrate into existing designs. The bearing housing can be part of a more complex design or machine structure. Compared to most other linear guide solutions, the integration is very easy

to realise. The tolerance of the housing bore and the shaft tolerance are building the base for the linear guide performance. For more information about the bearing range and dimensions, see **chapter 3.1** and **3.3**.

## Linear unit range

To build up linear slides from standard design elements, each range has an assortment of units and shaft blocks. A linear bearing unit is a standardised housing mostly made from aluminium already equipped with a linear ball bearing. The units have a defined performance and are made as single, tandem, duo or quadro units. These units provide the utmost ease and flexibility to build up a huge variety of linear slides, together with the shafts and shafts blocks. The schematics below show the differences between the unit assortment.

### Single units



Single units equipped with one linear bearing allow building up linear slides with flexible bearing distance and shaft distance.

### Tandem units



Tandem units equipped with two linear bearings in line allow building up slides with flexible shaft distance or slides with more performance.

### Duo units



Duo units equipped with two linear bearings in parallel allow slides with flexible bearing distance with fixed shaft distance.

### Quadro units



Quadro units equipped with four linear bearings are pre-mounted ready to use slides with fixed bearing and shaft distance.

### Flanged units



Flanged units are made for flexible mounting direction, when top or bottom mounting is not possible. They are single units for flexible bearing distance and shaft distance.

In each assortment of the compact and standard range, different variants of units are available to fit all possible installations and possible fixations of linear guide components. Most units are made for top or bottom mounting together with the shaft block from the same range. For machine wall mounting or side mounting, even flanged units are complementing the wide assortment. All in all, easy to install standardised components. For more information, see **chapter 3.2** and **3.4**.

## Shaft blocks and shaft supports

When the shaft fixation cannot be integrated into the machine design, the easiest way to do it is with Ewellix compact and standard shaft blocks or shaft supports. Shaft blocks are made to secure a safe clamping of the shaft and to have a defined precise fixation at the machine surface. Shaft supports are normally used at long linear travel distances to have a precise shaft fixation and to avoid shaft bending at long lengths. Shaft supports are bolted with the shaft. For more information, see **chapter 3.6**.



*Shaft with shaft blocks*



*Shaft with shaft support*

## Precision Shafts

Precise hardened shafts complete the linear bearing system. Important considerations for linear slide precision are the shaft outside tolerance, the roundness and the straightness. As the Ewellix linear bearings are high precision products, the shaft outside tolerance together with the bearing housing's inner tolerance define the clearance or preload of the linear slide system. Different shaft materials, designs and coatings are available for respective linear ball bearing diameters. For ease of use, Ewellix has defined shaft machining standards suitable for most applications. For more information see **chapter 3.7**.

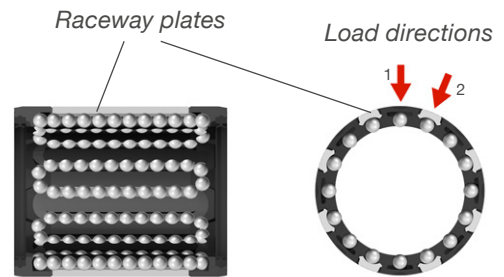


# 1.2 Features and benefits

## 1.2.1 Compact range

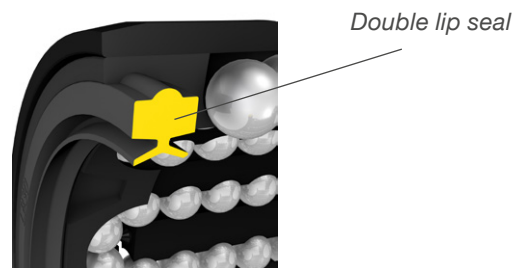
### High performance bearings

Compact linear ball bearings are high performance bearings for long rating life with nearly no maintenance. The cage design with raceway plates optimises load distribution between ball rows. The bearing's design which provides low friction and low noise, paired with high load ratings, is useful in many applications. Each bearing size has a maximum load direction, when mounted as shown in the picture to the right, which boosts performance.



### Double lip seal

LBBR compact bearings are optionally equipped with double lip seals for long service life. This perfectly fitted seal safely keeps contamination out and grease inside the linear bearing. The specific design ensures optimised sealing pressure towards the shaft for low friction. Perfect for applications with low maintenance, long service life and more environment friendly solutions of linear guides.



### Self-holding functionality

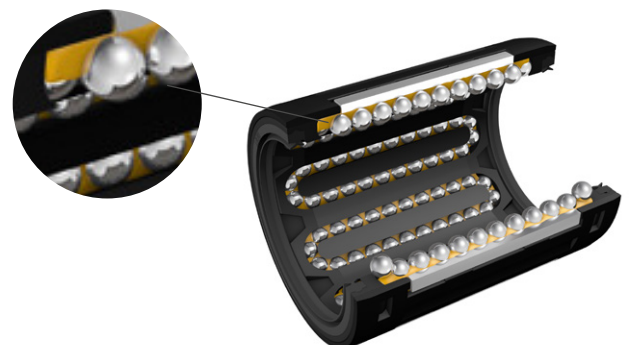
The cage design is made for a perfect press fit into the right housing tolerance. This means less mounting time, no damage during mounting, and low mounting force for compact LBBR bearings. The self-holding functionality has been proven by many satisfied customers in different applications. Compared to steel caged bearings, the Ewellix LBBR are easy to mount and do not damage housing tolerance when replacement is necessary.



### Lube for life under normal conditions

Times are over when you have installed a linear ball bearing and start to grease each ball row by hand before installation. Ewellix pre-lubricated bearings and units save mounting time and are ready to use. The compact range is greased for life under normal conditions.

Food compatible grease and other greases are available on request, if our standard grease SKF LGEP 2 does not fit.



## Miniaturisation down to size 3 mm

Downsizing and miniaturisation are trends in the market to realise lower energy consumption in motion or new miniature solutions. Compact linear ball bearings are supporting these trends by the sizes Ewellix offers in the market. From size 3 mm up to 50 mm onwards, customers can choose the right bearing size for their applications. Additionally, the ease of linear ball bearing integration into machine designs counts.



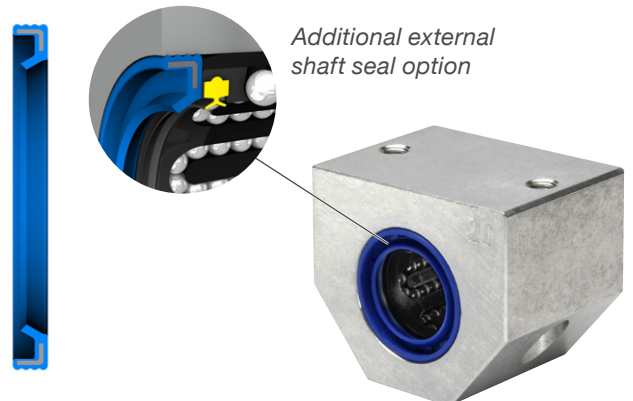
## Complete unit range

Standard applications need quick solutions where everything is predefined. The complete unit range makes it easy to pick the right bearing unit for flexible linear slide design. All parts are precisely ready machined and the bearings mounted. Together with shafts and shaft blocks, a linear slide solution can be realised in a few working days. That supports a quick way to meet the market for new demands.



## Harsh environment and contamination solution

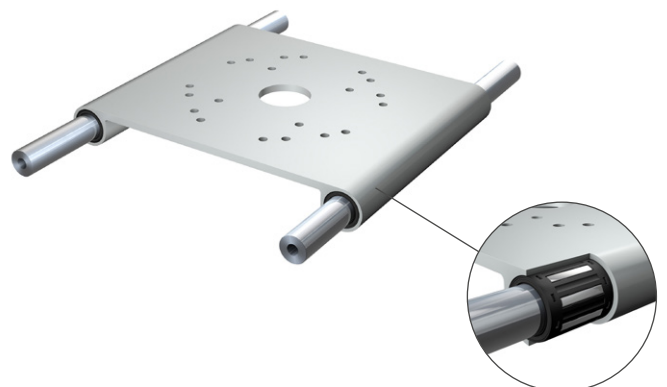
For the compact linear ball bearings range, Ewellix offers an additional front seal as an option. Harsh environmental and heavy contamination problems are gone. The external shaft seal is pressed as a front seal inside the bearing housing. It can be used as a single solution or as an additional solution together with the bearing integrated double lip seal. Ewellix offers the unit type LUJR in **chapter 3.2** with these features.



## Compacts are perfect for integration

You think about a machine design and need a linear slide function inside?

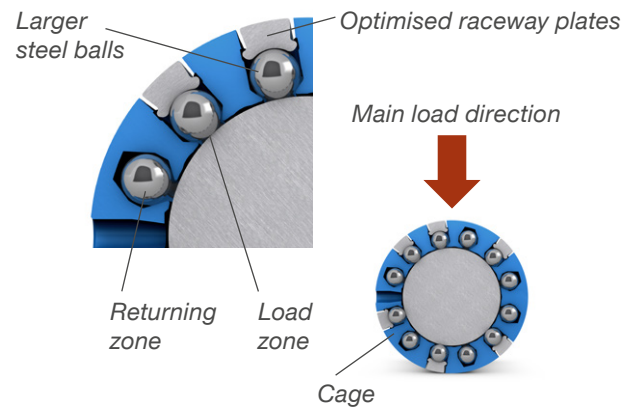
Contact your local Ewellix experts for realising an optimised solution based on the integration of linear ball bearings into your machine design. The picture to the right shows a customised housing made for a driver or patient seat motion as used in construction machines or medical treatment chairs.



## 1.2.2 Standard range

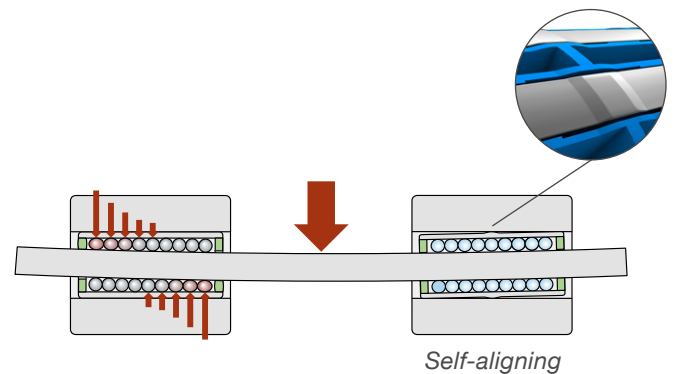
### Higher load ratings and rating life

Depending on the bearing size, LBC D-series linear ball bearings can deliver up to 15 % higher dynamic load ratings and up to 50 % longer rating life than previous bearing designs. Optimised raceway plates and larger rolling elements enable the performance increase. Consequently, LBC D-series bearings offer greater reliability and productivity for applications or give designers the flexibility to downsize.



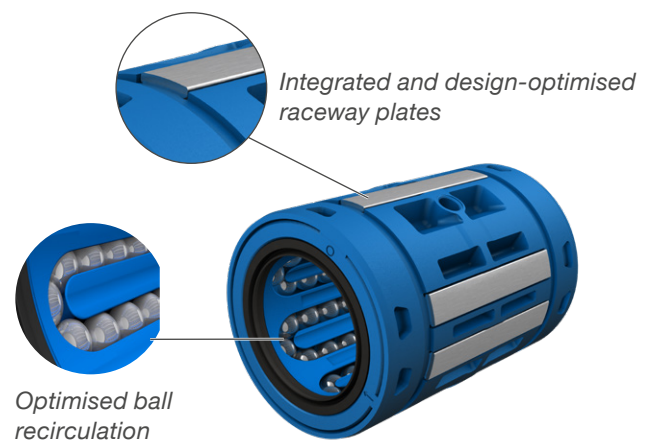
### Self-aligning capability

Standard LBCD and LBCF linear ball bearings have the self-aligning feature. These bearings can accommodate tilting of the bearing up to an angle of  $\pm 30$  minutes of arc. This tilting feature compensates for misalignments caused by fitting or manufacturing tolerances of the adjacent construction, or by significant bending of a precision shaft. Important, as the whole bearing is tilting the seals remain concentric around the shaft with full functionality. The results are less peak loads and finally an extended rating life of the bearing.



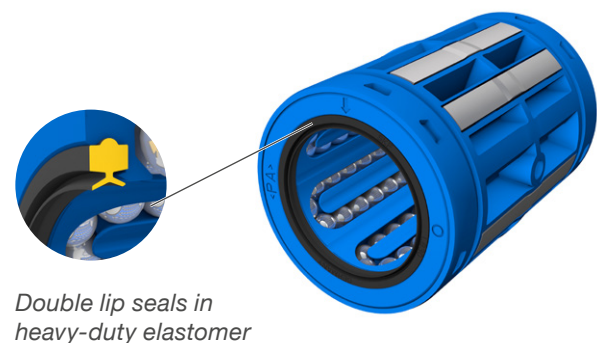
### Optimised cage design

LBC, D-series bearings have an optimised cage design. The new cage design features larger steel balls and raceway plates. Additionally, a grease reservoir and optimised ball recirculations are integrated. This combination helps to ensure smooth operation with less friction and low noise emissions, making LBC, D-series bearings a good option even for sensitive applications such as the medical industry.



### Perfect sealing function

All standard bearings of the LBC range can optionally be equipped with double lip seals. This heavy duty elastomer seal safely keeps contamination out and grease inside the linear bearing. In addition, the optimised sealing pressure towards the shaft ensures low friction. Perfect for applications with low maintenance, long service life and more environment friendly solutions of linear guides.

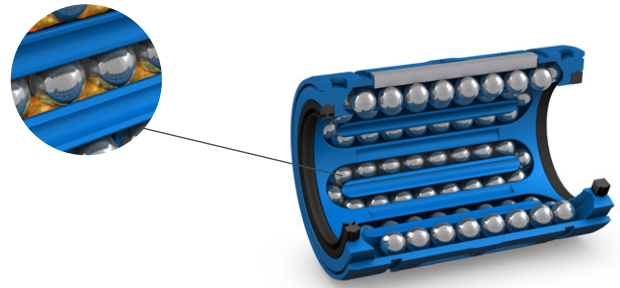


### Factory pre-lubrication

Times are over when you have installed a linear ball bearing and start to grease each ball row by hand before installation.

Ewellix pre-lubricated bearings and units save mounting time and are ready to use. This saves the cost of initial greasing and is beneficial for the planet as only the necessary amount for initial greasing is applied.

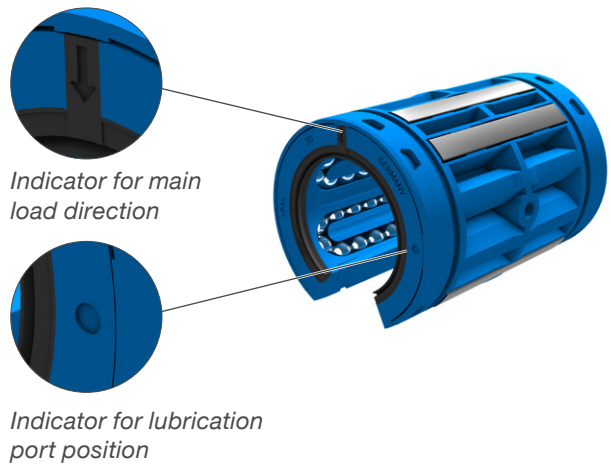
Food compatible grease and other greases are available on request if our standard grease SKF LGEP 2 does not fit.



### Easy mounting

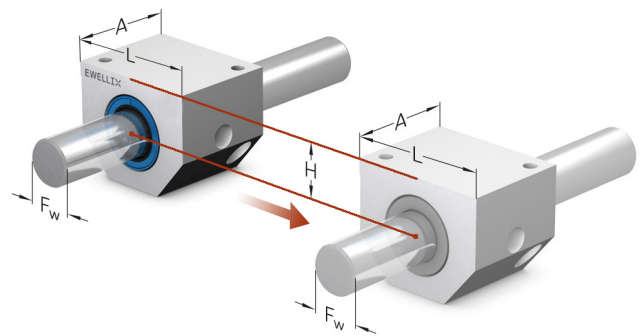
Ewellix linear bearings are easy to install and add safety.

There is an indicator for the main load direction that allows you to visually control the right mounting position for maximum performance. The lube and fixation hole indicator helps to find the correct mounting position and therefore avoids bearing or cage damage during installation.



### Full ISO interchangeability

LBC linear ball bearings are manufactured according to ISO 10285 dimensions and tolerances making them fully interchangeable with previous Ewellix series or ISO Series 3 bearings. For product designers and manufacturers, the LBC bearings offer a flexible, drop-in replacement option for existing equipment designs.



### Lightweight units and shaft blocks


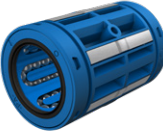

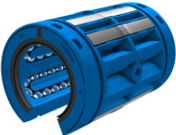
Ewellix linear ball bearings support the goal of saving energy in motion. Compared to most other housing solutions, the lightweight range from Ewellix offers significantly lower weight for linear guide slides. One lightweight die-cast bearing unit size 20 saves up to 42 % in weight compared to a standard aluminium unit made of extruded material. That's real energy saving potential.




# 1.3 Range overview

## 1.3.1 Overview assortment

### Linear ball bearings

Picture	Designation	Size	Max load rating dynamic / static	Comments	ISO series	Chapter
–	–	mm	N	–	–	–
	<b>LBBR</b> Compact bearing	3 to 50	7 100 / 6 950	–	1	3.1.1
	<b>LBCR</b> Standard bearing	5 to 80	37 500 / 32 000	–	3	3.3.1
	<b>LBCT</b> Standard bearing	12 to 50	11 200 / 6 950	Self-aligning <sup>1)</sup>	3	3.3.2
	<b>LBCT</b> Standard bearing open design	12 to 80	37 500 / 32 000	–	3	3.3.3
	<b>LBCF</b> Standard bearing open design	12 to 50	11 200 / 6 950	Self-aligning <sup>1)</sup>	3	3.3.4
	<b>LBHT</b> Standard heavy duty bearing open design	20 to 50	17 300 / 17 000	–	3	3.3.5

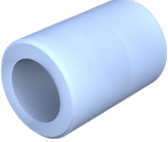
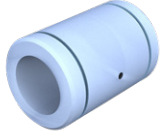
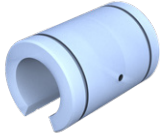
### External compact shaft seals

Picture	Designation	Size mm	Suitable for	Chapter
–	–	mm	–	–
	<b>SP</b>	6 to 50	Compact linear bearings	3.1.3






<sup>1)</sup> Automatic compensation of shaft misalignments of up to max. ±30 minutes of arc (L→ chapter 3.3)



## Linear plain bearings

Picture	Designation	Size	Max load rating dynamic / static	ISO series	Chapter
–	–	mm	N	–	
	<b>LPBR</b> Compact plain bearing	12 to 50	10 800 / 38 000	1	3.1.2
	<b>LPAR</b> Standard plain bearing	5 to 80	33 500 / 116 000	3	3.3.6
	<b>LPAT</b> Standard plain bearing open design	12 to 80	33 500 / 116 000	3	3.3.6





## Compact linear units

Picture	Housing	Designation	Bearing	Size	Max load rating dynamic / static	Chapter
–	–	–	–	mm	N	
	Closed, aluminium housing	<b>LUHR</b>	LBBR bearing	12 to 50	7 100 / 6 950	3.2.1
		<b>LUHR PB</b>	LPBR plain bearing	12 to 50	10 800 / 38 000	
	Closed, aluminium housing with shaft seals	<b>LUJR</b>	LBBR bearing	12 to 50	7 100 / 6 950	3.2.2
		<b>LUJR PB</b>	LPBR plain bearing	12 to 50	10 800 / 38 000	
	Tandem, closed, aluminium housing	<b>LTBR</b>	LBBR bearing	12 to 50	11 600 / 14 000	3.2.3
		<b>LTBR PB</b>	LPBR plain bearing	12 to 50	21 600 / 76 000	
	Duo, closed, aluminium housing	<b>LTDR</b>	LBBR bearing	12 to 50	11 600 / 14 000	3.2.4
		<b>LTDR PB</b>	LPBR plain bearing	12 to 50	21 600 / 76 000	
	Quadro, closed, aluminium housing	<b>LQBR</b>	LBBR bearing	12 to 50	19 000 / 28 000	3.2.5
		<b>LQBR PB</b>	LPBR plain bearing	12 to 50	43 200 / 152 000	




### Standard linear units

Picture	Housing	Designation	Bearing	Size	Max load rating dynamic / static	Chapter
-	-	-	-	mm	N	
	Closed, die-cast aluminium housing	<b>LUCR</b>	LBCR bearing	8 to 80	37 500 / 32 000	3.4.1
		<b>LUCD</b>	LBCD bearing, self-aligning <sup>1)</sup>	12 to 50	11 200 / 6 950	
		<b>LUCR PA</b>	LPAR plain bearing	8 to 80	33 500 / 116 000	
	Slotted, die-cast aluminium housing, clearance adjustable	<b>LUCS</b>	LBCR bearing	8 to 80	37 500 / 32 000	3.4.2
		<b>LUCE</b>	LBCD bearing, self-aligning <sup>1)</sup>	12 to 50	11 200 / 6 950	
	Open, die-cast aluminium housing	<b>LUCT</b>	LBCT bearing	12 to 80	37 500 / 32 000	3.4.3
		<b>LUCF</b>	LBCF bearing, self-aligning <sup>1)</sup>	12 to 50	11 200 / 6 950	
		<b>LUCT PA</b>	LPAT plain bearing	12 to 80	33 500 / 116 000	
	Heavy duty, open, die-cast aluminium housing	<b>LUCT BH</b>	LBHT bearing, heavy duty	20 to 50	17 300 / 17 000	3.4.4
	Closed, aluminium housing	<b>LUNR</b>	LBCR bearing	12 to 50	13 400 / 12 200	3.4.5
		<b>LUND</b>	LBCD bearing, self-aligning <sup>1)</sup>	12 to 50	11 200 / 6 950	
		<b>LUNR PA</b>	LPAR plain bearing	12 to 50	12 700 / 45 000	
	Slotted, aluminium housing, clearance adjustable	<b>LUNS</b>	LBCR bearing	12 to 50	13 400 / 12 200	3.4.6
		<b>LUNE</b>	LBCD bearing, self-aligning <sup>1)</sup>	12 to 50	11 200 / 6 950	
	Open, aluminium housing	<b>LUNT</b>	LBCT bearing	12 to 50	13 400 / 12 200	3.4.7
		<b>LUNF</b>	LBCF bearing, self-aligning <sup>1)</sup>	12 to 50	11 200 / 6 950	
		<b>LUNT PA</b>	LPAT plain bearing	12 to 50	12 700 / 45 000	
	Flanged, cast iron housing	<b>LVCR</b>	LBCR bearing	12 to 80	37 500 / 3 000	3.4.8
		<b>LVCD</b>	LBCD bearing, self-aligning <sup>1)</sup>	12 to 50	11 200 / 6 950	
		<b>LVCR PA</b>	LPAR plain bearing	12 to 80	33 500 / 116 000	

<sup>1)</sup> Automatic compensation of shaft misalignments of up to max. ±30 minutes of arc (L→ chapter 3.3)

Picture	Housing	Designation	Bearing	Size	Max load rating dynamic / static	Chapter
–	–	–	–	mm	N	
	Tandem, closed, aluminium housing	<b>LTCR</b>	LBCR bearing	12 to 50	21 600 / 24 500	3.4.9
		<b>LTCD</b>	LBCD bearing, self-aligning <sup>1)</sup>	12 to 50	18 300 / 14 000	
		<b>LTCR PA</b>	LPAR plain bearing	12 to 50	25 400 / 90 000	
	Tandem, open, aluminium housing	<b>LTCT</b>	LBCT bearing	12 to 50	21 600 / 24 500	3.4.10
		<b>LTCF</b>	LBCF bearing, self-aligning <sup>1)</sup>	12 to 50	18 300 / 14 000	
		<b>LTCT PA</b>	LPAT plain bearing	12 to 50	25 400 / 90 000	
	Quadro, closed, aluminium housing	<b>LQCR</b>	LBCR bearing	8 to 50	35 500 / 49 000	3.4.11
		<b>LQCD</b>	LBCD bearing, self-aligning <sup>1)</sup>	12 to 50	30 000 / 28 000	
		<b>LQCR PA</b>	LPAR plain bearing	8 to 50	50 800 / 180 000	
	Quadro, open, aluminium housing	<b>LQCT</b>	LBCT bearing	12 to 50	3 500 / 49 000	3.4.12
		<b>LQCF</b>	LBCF bearing, self-aligning <sup>1)</sup>	12 to 50	30 000 / 28 000	
		<b>LQCT PA</b>	LPAT plain bearing	12 to 50	50 800 / 180 000	

## Standard housings


Picture	Housing	Designation	Suitable for	Size	Chapter
–	–	–	–	mm	
	Closed, die-cast aluminium housing	<b>LHCR</b>	LBCR bearing	8 to 80	3.5.1
			LBCD bearing, self-aligning		
			LPAR plain bearing other standard bearings		
	Slotted, die-cast aluminium housing, clearance adjustable	<b>LHCS</b>	LBCR bearing	8 to 80	3.5.1
			LBCD bearing, self-aligning		
			other standard bearings		
	Open, die-cast aluminium housing	<b>LHCT</b>	LBCT bearing	12 to 80	3.5.2
			LBCF bearing, self-aligning		
			LPAT plain bearing other standard bearings		

<sup>1)</sup> Automatic compensation of shaft misalignments of up to max. ±30 minutes of arc (L→ chapter 3.3)

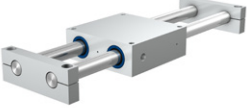
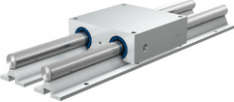
### Shaft blocks and shaft supports

Picture	Designation	Suitable for	Size	Comments	ISO series	Chapter
–	–	–	mm	–	–	–
	<b>LSCS</b>	Compact and standard range	8 to 80	–	1 / 3	3.6.1
	<b>LSHS</b>	Compact range	12 to 50	–	1	3.6.2
	<b>LSNS</b>	Standard range	12 to 50		3	3.6.3
	<b>LEBS A</b>	Compact range	12 to 50	Tandem	1	3.6.4
	<b>LEAS ... A/B</b>	Standard range	8 to 50	Tandem	3	3.6.5
	<b>LRCB</b> <b>LRCC</b>	Standard range	12 to 80	With holes Without holes	3	3.6.6

### Precision shafts

Picture	Designation	Shaft type	Material description	Size mm	Chapter
	<b>LJM</b> <b>LJMR</b> <b>LJMS</b> <b>LJMH</b> <b>LJT</b>	Solid shaft Solid shaft Solid shaft Solid shaft Hollow shaft	High grade steel High alloy stainless steel High alloy stainless steel High grade steel, hard chrome plated High grade steel	3 to 80 3 to 60 5 to 60 5 to 80 12 to 80	3.7

## Linear slides

Picture	Designation	Size	Max load rating dynamic / static	Comments	ISO series	Chapter
–	–	mm	N	–	–	–
	<b>LZBU ... A</b>	8 to 50	30 000 / 28 000	Quadro A = moving unit B = moving shafts LBCD bearing self-aligning <sup>1)</sup>	3	3.8.1
	<b>LZBU ... B</b>					3.8.2
	<b>LZAU</b>	12 to 50	30 000 / 28 000	Quadro supported shaft LBCF bearing self-aligning <sup>1)</sup>	3	3.8.3

<sup>1)</sup> Automatic compensation of shaft misalignments of up to max.  $\pm 30$  minutes of arc (L→ [chapter 3.3](#))

## 1.3.2 Overview of range and availability

### Ewellix linear ball bearings range and availability

Range	Assortment	Type	Feature	Variant	Design	Chapter		
–	–	–	–	–	–	–		
<b>Compact range</b>	Linear Bearings	LBBR	–	shielded	closed	3.1.1		
				sealed	closed			
				seal and shield	closed			
	Linear Units	LUHR	–	plain bearing	closed	3.1.2		
				external shaft seals	closed	3.1.3		
				single unit shielded	closed	3.2.1		
				single unit sealed	closed			
				single unit externally sealed	closed	3.2.2		
				single unit double sealed	closed			
				tandem unit shielded	closed	3.2.3		
				tandem unit sealed	closed			
				duo unit shielded	closed	3.2.4		
				duo unit sealed	closed			
				quadro unit shielded	closed	3.2.5		
quadro unit sealed	closed							
<b>Standard range</b>	Linear Bearings	LBCR	–	shielded	closed	3.3.1		
				sealed	closed			
				seal and shield	closed			
		LBCD	self-aligning	shielded	closed	3.3.2		
				sealed	closed			
				seal and shield	closed			
		LBCT	–	shielded	open	3.3.3		
				sealed	open			
				seal and shield	open			
		LBCF	self-aligning	shielded	open	3.3.4		
				sealed	open			
				seal and shield	open			
		LBHT	heavy duty	shielded	open	3.3.5		
				sealed	open			
				seal and shield	open			
	LPAR	–	plain bearing	closed	3.3.6			
			plain bearing	open				
			grease fittings	–		3.3.7		
	Linear Units	LUCR	–	single unit shielded	closed	3.4.1		
				single unit sealed	closed			
				single unit shielded	closed	3.4.1		
				single unit sealed	closed			
				LUCS	–	single unit shielded	slotted	3.4.2
						single unit sealed	slotted	
				LUCE	self-aligning	single unit shielded	slotted	3.4.2
						single unit sealed	slotted	
				LUCT	–	single unit shielded	open	3.4.3
						single unit sealed	open	
				LUCF	self-aligning	single unit shielded	open	3.4.3
						single unit sealed	open	
LUCT BH				heavy duty	single unit shielded	open	3.4.4	
					single unit sealed	open		
LUNR				–	single unit shielded	closed	3.4.5	
	single unit sealed	closed						
LUND	self-aligning	single unit shielded	closed	3.4.5				
		single unit sealed	closed					
LUNS	–	single unit shielded	slotted	3.4.6				
		single unit sealed	slotted					
LUNE	self-aligning	single unit shielded	slotted	3.4.6				
		single unit sealed	slotted					
LUNT	–	single unit shielded	open	3.4.7				
		single unit sealed	open					
LUNF	self-aligning	single unit shielded	open	3.4.7				
		single unit sealed	open					

Type	Size [mm]																Variant		
	3	4	5	6	8	10	12	14	16	20	25	30	40	50	60	80	HV6	PB	PA
LBBR	●	●	●	●	●	●	●	●	●	●	●	●	●	●	-	-	●	-	-
LPBR	-	-	-	-	-	-	●	●	●	●	●	●	●	●	-	-	-	-	-
SP	-	-	-	●	●	●	●	●	●	●	●	●	●	●	-	-	-	-	-
LUHR	-	-	-	-	-	-	●	-	●	●	●	●	●	●	-	-	●	●	-
LUJR	-	-	-	-	-	-	●	-	●	●	●	●	●	●	-	-	●	●	-
LTBR	-	-	-	-	-	-	●	-	●	●	●	●	●	●	-	-	-	●	-
LTDR	-	-	-	-	-	-	●	-	●	●	●	●	●	●	-	-	-	●	-
LQBR	-	-	-	-	-	-	●	-	●	●	●	●	●	●	-	-	-	●	-
LBCR	-	-	●	-	●	-	●	-	●	●	●	●	●	●	●	●	●	●	-
LBCD	-	-	●	-	●	-	●	-	●	●	●	●	●	●	●	●	●	●	-
LBCF	-	-	-	-	-	-	●	-	●	●	●	●	●	●	-	-	-	●	-
LBHT	-	-	-	-	-	-	-	-	-	●	●	●	●	●	-	-	-	●	-
LPAR	-	-	●	-	●	-	●	-	●	●	●	●	●	●	●	●	●	-	-
LPAT	-	-	-	-	-	-	●	-	●	●	●	●	●	●	●	●	●	-	-
VN-LHC	-	-	-	-	-	-	●	-	●	●	●	●	●	●	●	●	●	-	-
LUCR	-	-	-	-	●	-	●	-	●	●	●	●	●	●	●	●	●	●	●
LUCD	-	-	-	-	-	-	●	-	●	●	●	●	●	●	-	-	-	●	-
LUCS	-	-	-	-	●	-	●	-	●	●	●	●	●	●	●	●	●	●	-
LUCE	-	-	-	-	-	-	●	-	●	●	●	●	●	●	-	-	-	●	-
LUCT	-	-	-	-	-	-	●	-	●	●	●	●	●	●	●	●	●	●	●
LUCF	-	-	-	-	-	-	●	-	●	●	●	●	●	●	-	-	-	●	-
LUCT BH	-	-	-	-	-	-	-	-	-	●	●	●	●	●	-	-	-	●	-
LUNR	-	-	-	-	-	-	●	-	●	●	●	●	●	●	-	-	-	●	●
LUND	-	-	-	-	-	-	●	-	●	●	●	●	●	●	-	-	-	●	-
LUNS	-	-	-	-	-	-	●	-	●	●	●	●	●	●	-	-	-	●	-
LUNE	-	-	-	-	-	-	●	-	●	●	●	●	●	●	-	-	-	●	-
LUNT	-	-	-	-	-	-	●	-	●	●	●	●	●	●	-	-	-	●	●
LUNF	-	-	-	-	-	-	●	-	●	●	●	●	●	●	-	-	-	●	-

- Items usually available from stock
- Delivery time usually 10 days for max. quantity of 4; larger quantities on request
- Like ●, but except size 60 and 80
- Delivery time on request

## Ewellix linear ball bearings range and availability

Range	Assortment	Type	Feature	Variant	Design	Chapter		
–	–	–	–	–	–	–		
<b>Standard range</b>	Linear Units	LVCR	–	single unit shielded single unit sealed	flanged flanged	3.4.8		
		LVCD	self-aligning	single unit shielded single unit sealed	flanged flanged	3.4.8		
		LTCR	–	tandem unit shielded tandem unit sealed	closed closed	3.4.9		
		LTCD	self-aligning	tandem unit shielded tandem unit sealed	closed closed	3.4.9		
		LTCT	–	tandem unit shielded tandem unit sealed	open open	3.4.10		
		LTCF	self-aligning	tandem unit shielded tandem unit sealed	open open	3.4.10		
		LQCR	–	quadro unit shielded quadro unit sealed	closed closed	3.4.11		
		LQCD	self-aligning	quadro unit shielded quadro unit sealed	closed closed	3.4.11		
		LQCT	–	quadro unit shielded quadro unit sealed	open open	3.4.12		
		LQCF	self-aligning	quadro unit shielded quadro unit sealed	open open	3.4.12		
		Linear housings	LHCR	–	die-cast housing	closed	3.5.1	
			LHCS	–	die-cast housing	slotted	3.5.1	
			LHCT	–	die-cast housing	open	3.5.2	
		<b>Shaft blocks and supports</b>	Shaft blocks	LSCS	–	shaft block	–	3.6.1
				LSHS	–	compact block	–	3.6.2
LSNS	–			standard block	–	3.6.3		
LEBS	–			compact tandem block	A	3.6.4		
LEAS	–			standard tandem block	A	3.6.5		
Shaft supports	LEAS		–	standard tandem block	B	3.6.5		
	LRCB		–	standard support	–	3.6.6		
L RCC	–	standard support	–	3.6.6				
<b>Precision shafts</b>	Solid shaft	LJM	–	high-grade steel	–	3.7		
		LJMR	–	stainless steel	–			
		LJMS	–	stainless steel	–			
		LJMH	–	hard chrome plated	–			
	Hollow shaft	LJT	–	high-grade steel	–			
<b>Linear slides</b>	LZBU A	–	quadro manual driven	closed	3.8.1			
	LZBU B	–	shafts manual driven	closed	3.8.2			
	LZAU	–	quadro manual driven	open	3.8.3			



Type	Size [mm]																Variant		
	3	4	5	6	8	10	12	14	16	20	25	30	40	50	60	80	HV6	PB	PA
LVCR	-	-	-	-	-	-	●	-	●	●	●	●	●	●	●	●	-	-	●
LVCD	-	-	-	-	-	-	●	-	●	●	●	●	●	●	-	-	●	-	-
LTCT	-	-	-	-	-	-	●	-	●	●	●	●	●	●	-	-	-	-	●
LTCD	-	-	-	-	-	-	●	-	●	●	●	●	●	●	-	-	-	-	-
LQCR	-	-	-	-	●	-	●	-	●	●	●	●	●	●	-	-	-	-	●
LQCD	-	-	-	-	-	-	●	-	●	●	●	●	●	●	-	-	-	-	-
LQCT	-	-	-	-	-	-	●	-	●	●	●	●	●	●	-	-	-	-	●
LQCF	-	-	-	-	-	-	●	-	●	●	●	●	●	●	-	-	-	-	-
LHCR	-	-	-	-	●	-	●	-	●	●	●	●	●	●	●	●	-	-	-
LHCS	-	-	-	-	●	-	●	-	●	●	●	●	●	●	●	●	-	-	-
LHCT	-	-	-	-	-	-	●	-	●	●	●	●	●	●	●	●	-	-	-
LSCS	-	-	-	-	●	-	●	-	●	●	●	●	●	●	●	●	-	-	-
LSHS	-	-	-	-	-	-	●	-	●	●	●	●	●	●	-	-	-	-	-
LSNS	-	-	-	-	-	-	●	-	●	●	●	●	●	●	-	-	-	-	-
LEBS	-	-	-	-	-	-	●	-	●	●	●	●	●	●	-	-	-	-	-
LEAS	-	-	-	-	-	-	●	-	●	●	●	●	●	●	-	-	-	-	-
LRCB	-	-	-	-	-	-	●	-	●	●	●	●	●	●	●	●	-	-	-
LRCC	-	-	-	-	-	-	●	-	●	●	●	●	●	●	●	●	-	-	-
LJM	●	●	●	●	●	●	●	●	●	●	●	●	●	●	●	●	-	-	-
LJMR	●	●	●	●	●	●	●	●	●	●	●	●	●	●	●	●	-	-	-
LJMS	-	-	-	●	●	●	●	●	●	●	●	●	●	●	●	●	-	-	-
LJMH	-	-	●	●	●	●	●	●	●	●	●	●	●	●	●	●	-	-	-
LJT	-	-	-	-	-	-	●	-	●	●	●	●	●	●	●	●	-	-	-
LZBU A	-	-	-	-	●	-	●	-	●	●	●	●	●	●	-	-	●	-	-
LZBU B	-	-	-	-	●	-	●	-	●	●	●	●	●	●	-	-	●	-	-
LZAU	-	-	-	-	-	-	●	-	●	●	●	●	●	●	-	-	●	-	-

- Items usually available from stock
- Delivery time usually 10 days for max. quantity of 4; larger quantities on request; for precision shafts see details in **chapter 3.7.7**
- Like ●, but except size 60 and 80
- Delivery time on request

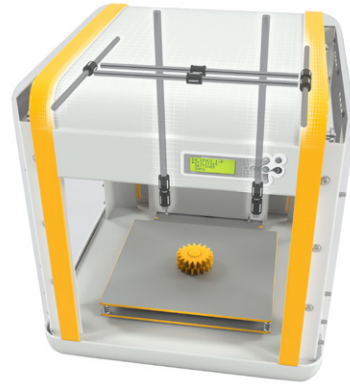
# 1.4 Applications of linear bearings

## 3D printer – Automation industry

The print head moves precisely in two dimensions and applies lines of melted plastic onto the print bed. After completion of one layer, the print bed moves downwards. Layer by layer is built until the desired 3D part is completed.

### Why linear ball bearings:

- Precise and vibration-free motion for accurate parts
- Comfortable noise level, suitable for office use
- Easy integration into customized housings
- No maintenance due to double lip seals

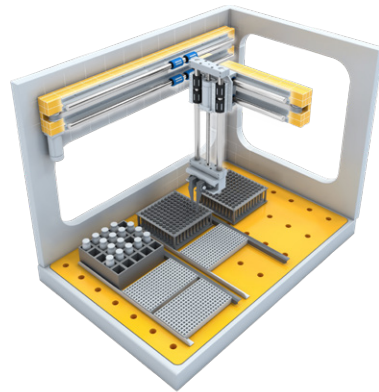


## Pick and place – Automation industry

Linear ball bearings are used for 3-dimensional precise motion in order to boost handling of components or test specimen.

### Why linear ball bearings:

- Low noise level for convenient work environment
- High speed and acceleration to increase output
- Low friction for reduced energy consumption
- No maintenance with double lip seal

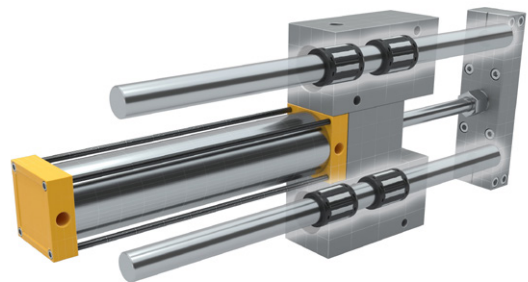


## Pneumatic slides – Automation industry

Pneumatic driven linear slides are used in many applications and industries, e.g. for lifting, pushing, transporting or handling of any kind of goods. The integrated linear ball bearings allow lateral loads onto the motion solution.

### Why linear ball bearings:

- Easy to mount, self-holding linear bearing
- Maintenance free due to factory pre-lubrication
- Robust against slight misalignment or bending
- Small sizes of mini slides follow the miniaturization trend

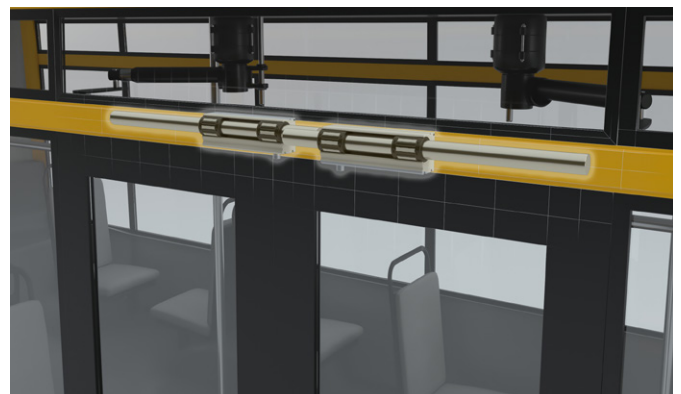


## Train and bus doors – Public transport

Train, tram and bus doors must open wide and safely throughout the day and all year long. The parallel side movement of the door systems and the rectangular unlock movement are based on linear ball bearing solutions.

### Why linear ball bearings:

- Long service life even in harsh environment
- Excellent sealing performance fits rough conditions
- Ewellix linear bearings fulfill EN 45545-2 railway norm
- Sealing performance fits rough environment



## Seat adjustment – General industry

Adjustable seats, e.g. for opticians, dentists or in special vehicles need low friction movement for best possible comfort and a high-quality impression. A unit with four parallel bearings can be used.

### Why linear ball bearings:

- Low friction and smooth running for manual adjustment
- Linear ball bearings compensate tolerances of surrounding
- Excellent sealing function for long service life

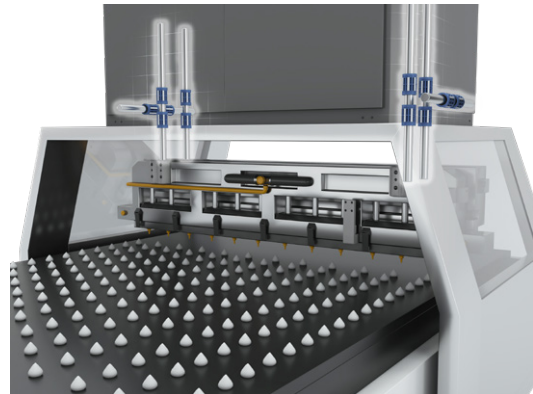


## Depositing system – Food & beverage

For automated food production e.g. ice cream, chocolate or biscuits a depositing system is required. The system deposits the correct dose onto a conveyor or into cups. The dispenser, guided by linear ball bearings, moves up and down and along the conveyor to achieve accurate results.

### Why linear ball bearings:

- Shaft guides as structure element help to increase machine cleanliness
- Few mechanical components near the food
- Very good sealing performance for longer service life
- Corrosion resistance by using stainless steel shafts and bearing



## Filling station – Food & beverage

To properly fill bottles with liquid the fillers move continuously upwards during the filling process. The linear ball bearings guide the vertical movement of the filler.

### Why linear ball bearings:

- Extremely good sealing performance with round shaft
- Corrosion resistance by using stainless steel bearings
- Customized grease options for food industry
- 24/7 operation thanks to high performing bearings

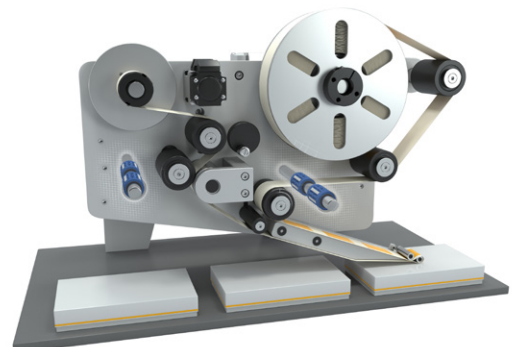


## Labelling machine - Packaging industry

Product labels need to be placed at different positions. The movement of the labeler is realized by linear ball bearings.

### Why linear ball bearings:

- Easy realization thanks to shafts as guide and structure element
- Stainless steel bearings and shafts for corrosion protection
- Low maintenance as bearings are pre-lubricated

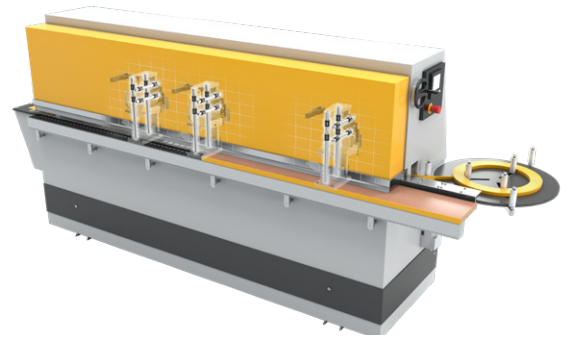


### Edge band machine – Woodworking

Plywood and chipboard work pieces are often equipped with edge bands for a high-quality appearance. Linear bearings adjust the pressing, milling and sanding units in these complex edge band machines.

#### Why linear ball bearings:

- Shaft solutions withstand wood dust best
- Double lip seals prolong service intervals
- High load ratings secure long rating life
- Shafts are used as guide and structure element



### Miter saw – Woodworking

The sliding miter saw is used to make a quick, accurate crosscut in a workpiece. The saw unit is guided by linear ball bearings running on chrome plated shafts.

#### Why linear ball bearings:

- Precise motion due to minimum operating clearance
- Extremely good sealing function to keep dust outside
- Smart design with shafts used as guide and structure element
- Maintenance free with pre-lubricated bearings

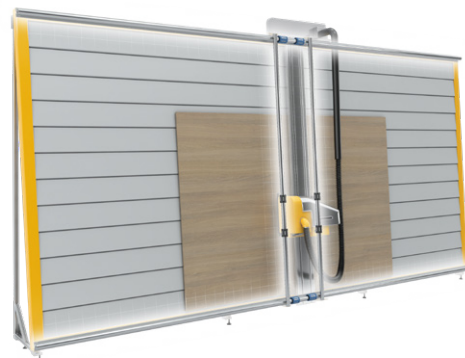


### Vertical panel saw – Woodworking

A panel saw cuts wooden, plastic or cement panels in vertical and horizontal direction. The movement of the saw is realized by linear ball bearings in both directions.

#### Why linear ball bearings:

- Low friction and smooth motion for manual operation
- Accurate cut results thanks to minimized clearance
- Long horizontal strokes and even joint shafts possible
- Vertical linear bearings perfectly work on unsupported shafts
- Long service life thanks to good sealing function



### Adjustable clamping unit – Woodworking

Machine centers for wooden parts have to deal with different sizes of work pieces. As these parts can also be quite long, there are several parallel clamping units with adjustable distance to ensure safe clamping.

#### Why linear ball bearings:

- Low friction for easy manual positioning
- Extremely good sealing function to avoid bearing contamination
- Low maintenance with pre-lubricated bearings
- Shaft surface protection by hard chrome plating



## Leg press machine – Fitness equipment

A leg press machine is used for fitness and rehabilitation. Linear bearings guide the footrest and smoothen the motion.

### Why linear ball bearings:

- Minimized friction with high quality linear ball bearings
- Low audible noise due to optimized ball recirculations
- Smooth motion even with misaligned shafts thanks to self-aligning capability
- Chrome plated shafts for corrosion protection



## Smith machine – Fitness equipment

Smith machines and multifunctional training racks are used for fitness and rehabilitation. Linear bearings guide the vertical movement of the dumb-bells or weights and smoothen the movement.

### Why linear ball bearings:

- Low noise and smooth running performance even with misaligned shafts
- No maintenance cost due to fit-for-life lubrication and corrosion resistance
- Extremely good sealing function to avoid lubricant on the shafts



## Long term injection – Medical industry

For medical treatment of patients, the dosing and regulation by long term injectors, also called syringe pumps, is utilized. Linear ball bearings secure the safety and precision of motion.

### Why linear ball bearings:

- Stick-slip free motion to allow consistent volume flow
- Extremely good sealing function for longest service life
- No maintenance with pre-lubricated bearings
- Shaft surface protection by hard chrome plating
- Corrosion resistance with stainless steel shafts



## Stretcher table adjustment – Medical industry

The patient bed is placed onto the stationary stretcher table. For more space flexibility the stretcher table is movable sideways, realized with linear units.

### Why linear ball bearings:

- Low friction for easy displacement by the ambulance staff
- Excellent sealing functionality for long service life
- Maintenance free
- Fixation of shafts with lowest design effort, just axial threads



2

## Selection guide



## 2.1 Technical data

### 2.1.1 Permissible operating conditions

The correct functioning of a linear ball bearing guiding system can only be maintained if the principal operating limits are not exceeded. The validity of the rating life calculations is based on the observance of the operating conditions described below.

#### Permissible operating temperatures

The permissible operating temperature range for continuous operation of Ewellix linear ball bearings is from  $-20$  to  $+80$  °C and is determined by the cage and seal materials. Lower and higher temperatures can be tolerated for brief periods.

#### Permissible speed and acceleration

Linear ball bearings can be used up to following limits:

Maximum speed:  $v_{\max} = 5$  m/s

Maximum acceleration:  $a_{\max} = 100$  m/s<sup>2</sup>

Higher running speeds and further acceleration are possible, depending on the bearing design, bearing size, applied load, lubricant and bearing preload. In such cases it is recommended to ask Ewellix for advice.

#### Required minimum load

In order to assure slip-free running of a linear ball bearing, as a general guideline, the load  $P \geq 0,02 \cdot C$  should be applied.

Minimum load is of special importance in linear guiding systems which operate at high speed or with high acceleration. In such cases, the inertia forces of the balls and the friction within the lubricant can have an adverse effect on the rolling conditions in the bearing and can lead to damaging slip conditions between the rolling elements and raceways.

#### Permissible maximum load

ISO 14728 Part 1 stipulates that calculation of bearing life is valid only when the equivalent dynamic mean load  $P_m$  of a linear bearing does not exceed 50 % of the dynamic load rating  $C$ . Any higher loading leads to an imbalance of stress distribution, which can have a negative impact on bearing life. As stated in ISO 14728 Part 2, the maximum load should not exceed 50 % of the static load rating  $C_0$ .

#### Standstill

**IMPORTANT:** Damage can occur to linear ball bearings when they are stationary for long periods and subjected to vibration from external sources. Micro-movement in the contact zone between rolling elements and raceways can damage the surfaces. This will cause a significant increase in running noise and premature failure through material fatigue. Damage of this kind through vibration when stationary should be avoided at all costs, for instance by isolating the bearings from external vibration and taking suitable precautions during transport.

## 2.1.2 Accuracy

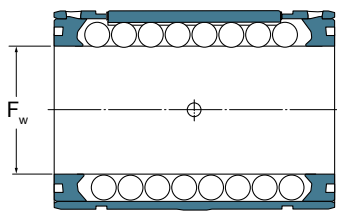
In general, the basic dimensions of Ewellix compact and standard linear ball bearings are according to ISO 10285. Ewellix linear ball bearings are manufactured to the tolerances indicated in **tables 1, 2** and **3**. The indicated values for max. and min. refer to the permissible deviation from the nominal values.

The next chapter explains how given values contribute to the clearance / preload characteristic of a linear guide.

**NOTE:** On request Ewellix offers linear ball bearings with customized values for  $F_{ws, max}$  and  $F_{ws, min}$ . It's feasible to shift  $F_{ws, max}$  and  $F_{ws, min}$  conjoined as well as to reduce the difference between  $F_{ws, max}$  and  $F_{ws, min}$  by about one international tolerance grade (IT-grade) related to the diameter of the shaft.

Table 1

Tolerances of inscribed diameter of the ball set of linear ball bearings



**Legend:**

- $F_w$  = nominal inscribed diameter of the ball set  
= nominal diameter of shaft
- $F_{ws, max}$  = largest inscribed diameter measurements of the ball set
- $F_{ws, min}$  = smallest inscribed diameter measurements of the ball set

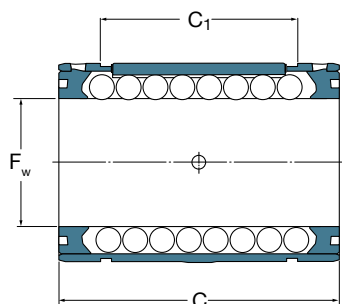
Size $F_w$ mm	Compact range			Standard range				Tolerance		Type		Tolerance	
	Type	Tolerance $F_{ws, max}$ $F_{ws, min}$ μm		Type				$F_{ws, max}$ $F_{ws, min}$ μm			$F_{ws, max}$ $F_{ws, min}$ μm		
3	LBBR	+12 0		-	-	-	-	-	-	-	-	-	-
4	LBBR	+15 0		-	-	-	-	-	-	-	-	-	-
5	LBBR	+15 0		LBCR	-	-	-	+12	0	-	-	-	-
6	LBBR	+15 0		-	-	-	-	-	-	-	-	-	-
8	LBBR	+18 0		LBCR	-	-	-	+16	0	-	-	-	-
10	LBBR	+18 0		-	-	-	-	-	-	-	-	-	-
12	LBBR	+21 0		LBCR	LBCD	LBCT	LBCF	+17	0	-	-	-	-
14	LBBR	+21 0		-	-	-	-	-	-	-	-	-	-
16	LBBR	+21 0		LBCR	LBCD	LBCT	LBCF	+17	0	-	-	-	-
20	LBBR	+26 0		LBCR	LBCD	LBCT	LBCF	+19	0	LBHT	-	+21	0
25	LBBR	+26 0		LBCR	LBCD	LBCT	LBCF	+19	0	LBHT	-	+21	0
30	LBBR	+26 0		LBCR	LBCD	LBCT	LBCF	+19	0	LBHT	-	+21	0
40	LBBR	+31 0		LBCR	LBCD	LBCT <sup>u)</sup>	LBCF <sup>u)</sup>	+21	0	LBHT	LBCT A	LBCF A	+25 0
50	LBBR	+31 0		LBCR	LBCD	LBCT	LBCF	+25	0	LBHT	-	+25	0
60	-	-		LBCR	-	LBCT	-	+30	0	-	-	-	-
80	-	-		LBCR	-	LBCT	-	+30	0	-	-	-	-

<sup>u)</sup> Size 40 under development; A-design linear ball bearing is available until replacement



Table 2

Tolerances of width of linear ball bearings



Legend:

- $F_w$  = nominal inscribed diameter of the ball set
- $F_w$  = nominal diameter of shaft
- C = width of linear ball bearing
- $C_1$  = distance between outer faces of outer sleeve snap ring grooves

Size $F_w$ mm	Compact range		Standard range					Tolerance				
	Type	Tolerance C mm	Type					C mm		$C_1$ -		
3	LBBR	$\pm 0,18$	-	-	-	-	-	-	-	-	-	-
4	LBBR	$\pm 0,215$	-	-	-	-	-	-	-	-	-	-
5	LBBR	$\pm 0,215$	LBCR	-	-	-	-	0	-0,52	+0,27	0	-
6	LBBR	$\pm 0,26$	-	-	-	-	-	-	-	-	-	-
8	LBBR	$\pm 0,26$	LBCR	-	-	-	-	0	-0,52	+0,27	0	-
10	LBBR	$\pm 0,26$	-	-	-	-	-	-	-	-	-	-
12	LBBR	$\pm 0,26$	LBCR	LBCD	LBCT	LBCF	-	0	-0,62	+0,33	0	-
14	LBBR	$\pm 0,26$	-	-	-	-	-	-	-	-	-	-
16	LBBR	$\pm 0,26$	LBCR	LBCD	LBCT	LBCF	-	0	-0,62	+0,33	0	-
20	LBBR	$\pm 0,26$	LBCR	LBCD	LBCT	LBCF	LBHT	0	-0,62	+0,39	0	-
25	LBBR	$\pm 0,31$	LBCR	LBCD	LBCT	LBCF	LBHT	0	-0,74	+0,39	0	-
30	LBBR	$\pm 0,31$	LBCR	LBCD	LBCT	LBCF	LBHT	0	-0,74	+0,46	0	-
40	LBBR	$\pm 0,37$	LBCR	LBCD	LBCT	LBCF	LBHT	0	-0,74	+0,46	0	-
50	LBBR	$\pm 0,37$	LBCR	LBCD	LBCT	LBCF	LBHT	0	-0,87	+0,6	0	-
60	-	-	LBCR	-	LBCT	-	-	0	-1	+0,8	0	-
80	-	-	LBCR	-	LBCT	-	-	0	-1	+1	0	-

## Operating clearance

With Ewellix slotted housings, the total clearance of a mounted linear ball bearing can be adjusted from light clearance to preload, according to the need of the application. This can be done with slotted units like: LUCS, LUCE, LUNS, LUNE, as well as for all single open units.

For Ewellix linear ball bearings in housings with fixed diameter, the total clearance of the mounted linear ball bearing is accumulated by

- the housing bore tolerance (↳ **chapter 4.1.2**),
- the radial clearance of the unmounted linear ball bearing (↳ **chapter 2.1.2**),
- the shaft diameter tolerance (↳ **chapter 3.7.6**).

The predicted operating clearance for the various bearing designs may be obtained from **tables 3, 4** and **5** for shaft tolerances of h6 and h7 and 6 variations of housing bore tolerances. While the first line states the theoretically possible limiting values of the operating clearance after mounting (grey background), the second line indicates the limiting values reached with more than 99 % reliability assuming Gaussian normal distribution of individual tolerances.

**NOTE:** With relatively rough housing bores or during running in, this operating clearance can be increased by smoothing.

**NOTE:** At operating temperature, the ambient temperature as well as the temperature of the shaft, bearing and housing and the housing material also influence the operating clearance.

Table 3

Tolerances of inscribed diameter of the ball set of compact linear ball bearings

Designation	Theoretical and predicted operating clearance											
	with shaft tolerance h6 and housing tolerance						with shaft tolerance h7 and housing tolerance					
	H6 max µm	min	J6 max	min	K6 max	min	H7 max µm	min	J7 max	min	K7 max	min
LBBR 3	27	0	23	-4	20	-7	37	0	30	-7	27	-10
	22	5	18	1	15	-2	29	8	22	1	19	-2
LBBR 4	32	0	28	-4	25	-7	42	0	35	-7	32	-10
	26	6	22	2	19	-1	33	9	26	2	23	-1
LBBR 5	32	0	28	-4	25	-7	42	0	35	-7	32	-10
	26	6	22	2	19	-1	33	9	26	2	23	-1
LBBR 6	34	0	29	-5	25	-9	45	0	37	-8	33	-12
	27	7	22	2	18	-2	36	9	28	1	24	-3
LBBR 8	38	0	33	-5	29	-9	51	0	43	-8	39	-12
	30	8	25	3	21	-1	40	11	32	3	28	-1
LBBR 10	38	0	33	-5	29	-9	51	0	43	-8	39	-12
	30	8	25	3	21	-1	40	11	32	3	28	-1
LBBR 12	45	0	40	-5	34	-11	60	0	51	-9	45	-15
	36	9	31	4	25	-2	47	13	38	4	32	-2
LBBR 14	45	0	40	-5	34	-11	60	0	51	-9	45	-15
	36	9	31	4	25	-2	47	13	38	4	32	-2
LBBR 16	45	0	40	-5	34	-11	60	0	51	-9	45	-15
	36	9	31	4	25	-2	47	13	38	4	32	-2
LBBR 20	52	0	47	-5	41	-11	68	0	59	-9	53	-15
	42	10	37	5	31	-1	54	14	45	5	39	-1
LBBR 25	55	0	49	-6	42	-13	72	0	61	-11	54	-18
	44	11	38	5	31	-2	57	15	46	4	39	-3
LBBR 30	55	0	49	-6	42	-13	72	0	61	-11	54	-18
	44	11	38	5	31	-2	57	15	46	4	39	-3
LBBR 40	66	0	60	-6	51	-15	86	0	74	-12	65	-21
	53	13	47	7	38	-2	68	18	56	6	47	-3
LBBR 50	66	0	60	-6	51	-15	86	0	74	-12	65	-21
	53	13	47	7	38	-2	68	18	56	6	47	-3

Table 4

Tolerances of inscribed diameter of the ball set of standard linear ball bearings

Designation	Theoretical and predicted operating clearance											
	with shaft tolerance h6 and housing tolerance						with shaft tolerance h7 and housing tolerance					
	H6 max µm	min	J6 max	min	K6 max	min	H7 max µm	min	J7 max	min	K7 max	min
LBC_ 5	31	0	26	-5	22	-9	42	0	34	-8	30	-12
	25	6	20	1	16	-3	33	9	25	1	21	-3
LBC_ 8	36	0	31	-5	27	-9	49	0	41	-8	37	-12
	29	7	24	2	20	-2	39	10	31	2	27	-2
LBC_ 12	41	0	36	-5	30	-11	56	0	47	-9	41	-15
	33	8	28	3	22	-3	44	12	35	3	29	-3
LBC_ 16	41	0	36	-5	30	-11	56	0	47	-9	41	-15
	33	8	28	3	22	-3	44	12	35	3	29	-3
LBC_ 20	48	0	42	-6	35	-13	65	0	54	-11	47	-18
	38	10	32	4	25	-3	51	14	40	3	33	-4
LBC_ 25	48	0	42	-6	35	-13	65	0	54	-11	47	-18
	38	10	32	4	25	-3	51	14	40	3	33	-4
LBC_ 30	48	0	42	-6	35	-13	65	0	54	-11	47	-18
	38	10	32	4	25	-3	51	14	40	3	33	-4
LBC_ 40	56	0	50	-6	41	-15	76	0	64	-12	55	-21
	44	12	38	6	29	-3	60	16	48	4	39	-5
LBC_ 50	60	0	54	-6	45	-15	80	0	68	-12	59	-21
	48	12	42	6	33	-3	63	17	51	5	42	-4
LBC_ 60	71	0	65	-6	53	-18	95	0	82	-13	70	-25
	56	15	50	9	38	-3	75	20	62	7	50	-5
LBC_ 80	71	0	65	-6	53	-18	95	0	82	-13	70	-25
	56	15	50	9	38	-3	75	20	62	7	50	-5

Table 5

Tolerances of inscribed diameter of the ball set of heavy duty linear ball bearings

Designation	Theoretical and predicted operating clearance											
	with shaft tolerance h6 and housing tolerance						with shaft tolerance h7 and housing tolerance					
	H6 max µm	min	J6 max	min	K6 max	min	H7 max µm	min	J7 max	min	K7 max	min
LBHT 20	50	0	44	-6	37	-13	67	0	56	-11	49	-18
	40	10	34	4	27	-3	53	14	42	3	35	-4
LBHT 25	50	0	44	-6	37	-13	67	0	56	-11	49	-18
	40	10	34	4	27	-3	53	14	42	3	35	-4
LBHT 30	50	0	44	-6	37	-13	67	0	56	-11	49	-18
	40	10	34	4	27	-3	53	14	42	3	35	-4
LBHT 40	60	0	54	-6	45	-15	80	0	68	-12	59	-21
	48	12	42	6	33	-3	63	17	51	5	42	-4
LBHT 50	60	0	54	-6	45	-15	80	0	68	-12	59	-21
	48	12	42	6	33	-3	63	17	51	5	42	-4



## 2.1.3 Rigidity

### Rigidity of linear ball bearing guides

Next to its load carrying capacity (→ **chapter 2.2**), the deflection of a linear guiding system is one of the most significant criteria for the selection of a suitable system. Stiffness is defined as the ratio between load and deflection at the point of application of load and in the direction of load. The deflection of the individual elements normally contributes to the total deflection; parallel and series linking of the individual elements must be taken into consideration.

- Because of the convex-convex contact between the shaft and balls, the linear ball bearing guide possesses the least rigidity of the various linear guiding systems.
- Furthermore, in the case of unsupported guides, the deflection of the shaft under load reduces the rigidity of the system significantly. The contribution of the shaft deflection to the total deflection will be explained in paragraph "Deflection and misalignment of shafts".

### Elastic deformation of clearance free linear ball bearing in the contact zone

Based on a clearance-free guide, the elastic deformations of various linear ball bearings depending on the load are shown in **diagrams 1, 2** and **3**. In the graphs, the load is characterized as a fraction with static load rating  $C_0$  as denominator. With preloaded guides, the elastic deformations will be smaller, i.e. rigidity is higher than that given in the diagrams.

**NOTE:** If radial clearance occurs (→ **chapter 2.1.2**), higher elastic deformation has to be expected. In case of alternating load directions, it may also be necessary to insert the radial clearance as reverse clearance in the calculation.

Diagram 1

Elastic deformation of clearance-free compact linear ball bearings in the ball contact zone

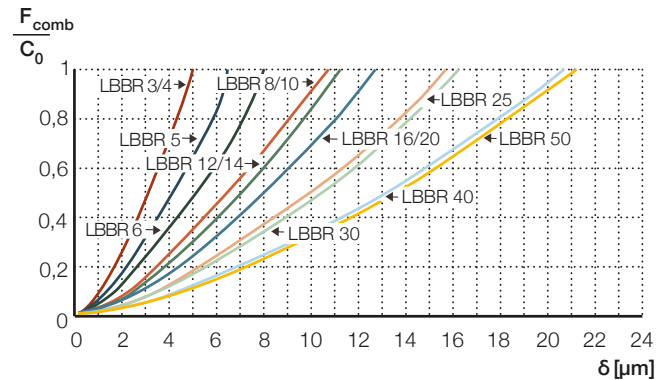


Diagram 2

Elastic deformation of clearance-free standard linear ball bearings in the ball contact zone

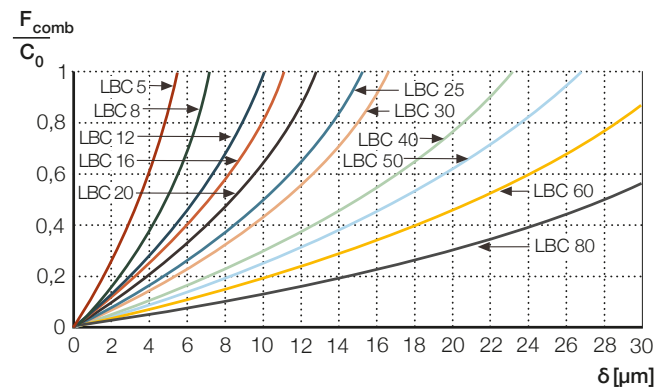
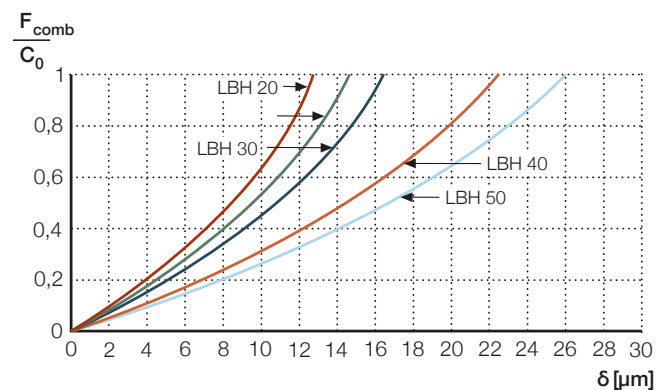


Diagram 3

Elastic deformation of clearance-free heavy duty linear ball bearings in the ball contact zone



where:

$C_0$  = basic static load rating [N] (→ **chapter 2.2.1**)

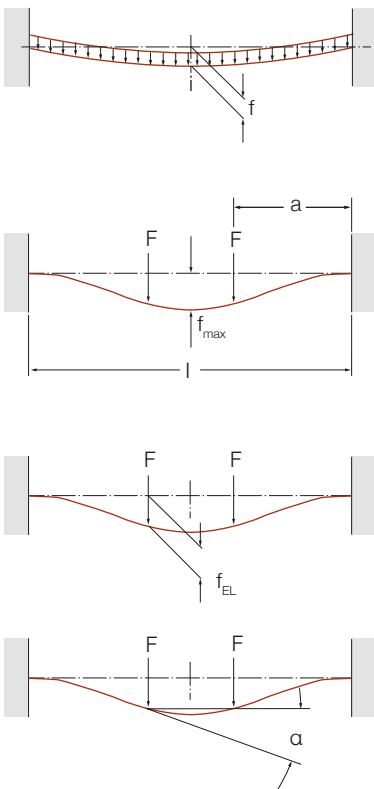
$F_{comb}$  = combined bearing load [N] (→ **chapter 2.2.2**)

## Deflection and misalignment of shafts

For an approximate determination of shaft deflection and shaft misalignment in relation to the axis of symmetry (length direction) of the linear bearing, the calculation formulae shown in **diagram 4** should be used. The general theory about strength of materials is the base for given formulae. Here it is assumed that the least favourable load conditions exist, i.e. that the linear bearing unit is situated at the center position between the shaft blocks. Bending of the shaft due to its own weight must also be considered. It is also assumed that the shaft is clamped or freely supported at both ends. In this way the maximum value for the expected deflection is obtained. For further details and an example calculation, see **chapter 2.2.5**.

Diagram 4

Deflection and misalignment of solid or hollow steel shafts, clamped or freely supported  
 Calculated using  $E = 206\,000\text{ N/mm}^2$  and  $G = 77\,000\text{ N/m}^3$



**Indices for results at the loading points (at distance a):**  
 EG = clamped shaft under its own weight  
 EL = clamped shaft under 2 symmetrical individual loads F  
 FG = freely supported shaft under its own weight  
 FL = freely supported shaft under 2 symmetrical individual loads F

**Index for result at the middle of the shaft:**  
 max = maximum deflection

**a) Clamped shaft**

under its own weight:

$$f_{EG} = 2,49 \cdot 10^{-7} \cdot [a \cdot (l - a)]^2 / (d^2 + d_1^2)$$

$$f_{max,EG} = 1,56 \cdot 10^{-8} \cdot l^4 / (d^2 + d_1^2)$$

$$\alpha_{EG} = 1,71 \cdot 10^{-6} \cdot a \cdot (l^2 + 2a^2 - 3al) / (d^2 + d_1^2)$$

under 2 symmetrical individual loads F:

$$f_{EL} = 0,0165 \cdot F \cdot a^3 \cdot (2 - 3a/l) / (d^4 - d_1^4)$$

$$f_{max,EL} = 0,00412 \cdot F \cdot a^2 \cdot (3l - 4a) / (d^4 - d_1^4)$$

$$\alpha_{EL} = 0,17 \cdot F \cdot a^2 \cdot (1 - 2a/l) / (d^4 - d_1^4)$$

In total:

$$\alpha_{ges} = \alpha_{EG} + \alpha_{EL}$$

**b) Freely supported shaft**

under its own weight:

$$f_{FG} = 2,49 \cdot 10^{-7} \cdot a \cdot (l - a) \cdot (l^2 - a^2 + al) / (d^2 + d_1^2)$$

$$f_{max,FG} = 7,78 \cdot 10^{-8} \cdot l^4 / (d^2 + d_1^2) = 5 \cdot f_{max,EG}$$

$$\alpha_{FG} = 8,57 \cdot 10^{-7} \cdot (l^3 + 4a^3 - 6a^2l) / (d^2 + d_1^2)$$

under 2 symmetrical individual loads F:

$$f_{FL} = 0,0165 \cdot F \cdot a^2 \cdot (3l - 4a) / (d^4 - d_1^4)$$

$$f_{max,FL} = 0,00412 \cdot F \cdot a \cdot (3l^2 - 4a^2) / (d^4 - d_1^4)$$

$$\alpha_{FL} = 0,17 \cdot F \cdot a \cdot (l - 2a) / (d^4 - d_1^4)$$

In total:

$$\alpha_{ges} = \alpha_{FG} + \alpha_{FL}$$

**Legend:**

- f = shaft deflection, [ $\mu\text{m}$ ]
- $\alpha$  = misalignment, [minutes of arc] = [']
- F = bearing load, [N]
- l = shaft length, [mm]
- d = shaft diameter, [mm]
- $d_1$  = inner diameter of hollow shaft, [mm]
- a = distance between clamping and point of application of load, [mm]

## 2.1.4 Friction

Friction in a linear guiding system is affected, apart from the loading, by a number of other factors, notably the type and size of the bearing, the operating speed, as well as the quality and quantity of the lubricant used.

The cumulative running resistance of a linear ball bearing is defined by the levels of several factors:

- rolling and sliding friction at rolling elements in the loaded area
- sliding friction between rolling elements and cage when returning
- friction within the lubricant
- sliding friction of the contact seals when applicable

The coefficients of friction for lubricated, shielded linear ball bearings are between 0,0015 (heavy loads) and 0,005 (light loads). If bearings with contact double-lip seals are used, the starting and running friction values (→ table 6) of the seals have to be added to the friction calculated with above coefficients of friction.

For lightly loaded linear ball bearings, the lubricant has a marked effect on the frictional properties. If using a grease with minimum viscosity according to our recommendations, the linear ball bearings will give a correspondingly higher level of basic friction compared to those using a grease with lower viscosity. This effect, however, will be reduced to a minimum after a certain period, as the grease inside the linear ball bearing becomes evenly distributed, and the surplus is removed from the ball return paths (running-in effect).

Table 6

Running friction and starting friction for unloaded, factory pre-lubricated <sup>1)</sup> linear ball bearings with seals at both ends

Size	Compact range				Standard range				Running friction	Starting friction	Type	Running friction	Starting friction	
	F <sub>w</sub>	Type	Running friction	Starting friction	Type	Running friction	Starting friction	Type						
mm	–	N	–	–	–	–	–	N	–	–	N	–	–	
3	LBBR	0,4	1,0	–	–	–	–	–	–	–	–	–	–	
4	LBBR	0,5	1,3	–	–	–	–	–	–	–	–	–	–	
5	LBBR	0,6	1,7	LBCR	–	–	–	0,8	2	–	–	–	–	
6	LBBR	0,7	2,0	–	–	–	–	–	–	–	–	–	–	
8	LBBR	0,8	2,5	LBCR	–	–	–	1,5	4	–	–	–	–	
10	LBBR	1,0	3,5	–	–	–	–	–	–	–	–	–	–	
12	LBBR	1,5	5,0	LBCR	LBCD	LBCT	LBCF	2,5	5	–	–	–	–	
14	LBBR	1,8	6,0	–	–	–	–	–	–	–	–	–	–	
16	LBBR	2,0	7,0	LBCR	LBCD	LBCT	LBCF	3	7	–	–	–	–	
20	LBBR	2,5	8,0	LBCR	LBCD	LBCT	LBCF	4	8	LBHT	–	–	4	12
25	LBBR	4,0	12,0	LBCR	LBCD	LBCT	LBCF	5	11	LBHT	–	–	5	14
30	LBBR	5,5	16,0	LBCR	LBCD	LBCT	LBCF	7	14	LBHT	–	–	6	18
40	LBBR	6,5	20,0	LBCR	LBCD	LBCT <sup>u)</sup>	LBCF <sup>u)</sup>	8	19	LBHT	LBCT A	LBCF A	8	24
50	LBBR	8,0	24,0	LBCR	LBCD	LBCT	LBCF	10	30	LBHT	–	–	10	30
60	–	–	–	LBCR	–	LBCT	LBCF	12	36	LBHT	–	–	12	36
80	–	–	–	LBCR	–	LBCT	LBCF	15	45	–	–	–	15	45

<sup>u)</sup> Size 40 under development; A-design linear ball bearing is available until replacement

<sup>1)</sup> As described in chapter 4.3.2

# 2.2 Dimensioning of linear bearings

## 2.2.1 Calculation bases

To determine which bearing is the most suitable for your application, we recommend that you make the following calculations:

- Calculation of rating life
- Calculation of static safety factor

These two proven and established calculation methods must consider all loads and forces acting on the linear guide system with linear ball bearings.

Representatives of the acting bearing load that describe the whole load case are needed. These representatives must combine all forces, lever arms and torque loads, which can vary by time or stroke. The details and different formulae for the load calculation are explained in **chapter 2.2.2**. The rating life of a linear guide with rolling elements is defined as the total linear distance travelled by the linear bearing before the first sign of material fatigue occurs on one of the raceways, shafts or the rolling elements. For the selection of a linear guide based on rating life calculation, the dynamic load rating C is used. It is expressed as the load that results in a bearing life of 100 km.

### The concept of static safety factor calculation

When selecting a linear guide, the static safety factor calculation must be considered when one of the following cases arises:

- The linear guide operates under load at very low speeds.
- The linear guide operates at normal conditions but must also accept heavy shock loads.
- The linear guide is loaded stationary for long periods of time.
- The linear guide is loaded with  $P > 50\%$  of the dynamic load rating C where the theory of rating life calculation is not valid anymore.

In all such cases, the permissible load is determined not through material fatigue but through the permanent physical deformation at the contact zone of the rolling elements and raceways. Loads applied when stationary or at very low operating speeds, as well as heavy shock loads, cause flattening of the rolling elements and result in damage to the raceways at the shaft or at the linear ball bearing. The damage may be uneven or may be spaced along the raceway at in-

tervals corresponding to the rolling element separation. This permanent deformation leads to vibration in the bearing, more noise and increased friction and may even cause a decrease in preload and, at an advanced stage, an increase in clearance. With continued operation, this permanent deformation may become a starting point for fatigue damage due to resulting peak loads. The severity of these phenomena depends on the particular bearing application.

### The method of static safety factor calculation

When determining the bearing size according to static load rating (↳ product tables in **chapter 3**), one must consider a certain relationship, known as the static safety factor  $s_0$ , between the static load rating  $C_0$  and the maximum static load  $P_0$ . The static safety factor  $s_0$  determines the degree of safety against excessive permanent deformation of the rolling elements and raceways. The static load rating,  $C_0$ , is defined as the static load that would produce a permanent deformation of 0,0001 times the rolling element diameter. Experience shows that, depending on the contact conditions, a maximum Hertzian pressure of 5300 MPa is permissible at the zone of maximum load without affecting the running qualities of the bearing. See also ISO 14728-2.

### Calculation of the static safety factor

For a chosen linear guide and a defined load case, the static safety factor  $s_0$  can be calculated as follows.

If maximum load occurs during standstill:

$$(1) \quad s_0 = \frac{C_0}{P_0}$$

If maximum load occurs when linear guiding moves:

$$(2) \quad s_0 = \frac{C_0}{P_{max}}$$

where:

$s_0$  = static safety factor

$C_0$  = basic static load rating [N]

$P_0$  = maximum static load [N]

$P_{max}$  = maximum equivalent load [N]

Depending on the operating conditions, a static safety factor  $s_0$  according to **table 7** is recommended.

**Table 7**

*Static safety factor depending on operating conditions*

Operating conditions	$s_0$
Normal conditions	> 1–2
Low vibration or impact loads	> 2–4
Medium vibrations or impact loads	3–5
High vibrations or impact loads	> 5
Overhead installations	The general technical rules and standards in the respective industrial sector must be observed. If the application poses a risk of serious injury, the user must take appropriate design and safety measures that will prevent all components from becoming detached from the base (e.g. due to loss of rolling elements or failure of screw connections).

If, for example, the linear guide system is exposed to external vibrations from machinery in close proximity, higher safety factors should be applied. Moreover, the load transfer paths between the linear guide system and its support structure should be considered.

**IMPORTANT:** In particular, the screw connections must be examined for adequate safety. For overhead installations of linear guides, higher safety factors should be applied.

**NOTE:** The general technical rules and standards in the respective industrial sector also must be observed.

### Requisite static load rating

For specific operating conditions with a related recommended static safety factor and a defined load case, the requisite static load rating  $C_0$  can be calculated from the following formulae:

If maximum load occurs during standstill:

$$(3) \quad C_0 = s_0 \cdot P_0$$

If maximum load occurs when linear guiding moves:

$$(4) \quad C_0 = s_0 \cdot P_{\max}$$

where:

$C_0$  = basic static load rating [N]

$s_0$  = static safety factor

$P_0$  = maximum static load [N]

$P_{\max}$  = maximum equivalent load [N]

### Rating life

In laboratory tests and in practice, it has been found that the rating life of apparently similar bearings under completely identical running conditions can differ. Therefore, calculation of the appropriate bearing size requires a full understanding of the concept of bearing rating life. All references to the dynamic load rating of Ewellix linear ball bearings apply to the basic rating life, as covered by the ISO definition (ISO 14728-1), in which the rating life is understood as the life reached or exceeded by 90 % of a large group of identical bearings. The majority of the bearings reach a longer rating life, and half the total number of bearings reach at least five times the basic rating life.

### Rating life calculation

The rating life of linear guides expressed in km,  $L_{ns}$ , can be calculated using the following formula:

$$(5) \quad L_{ns} = 100 \cdot \left( \frac{C}{P} \right)^p$$

In load cases where the length of travel and stroke frequency is constant, it is often more useful to calculate the rating lives in operating hours,  $L_{nh}$ , using the following formula:

$$(6) \quad L_{nh} = \frac{5 \cdot 10^7}{S_{\sin} \cdot n \cdot 60} \left( \frac{C}{P} \right)^p$$

where:

$L_{ns}$  = modified basic rating life [km]

$L_{nh}$  = modified basic rating life [h]

$C$  = dynamic load rating [N]

$P$  = equivalent dynamic load [N]

$p$  = life exponent;  $p = 3$  for balls,  $p = 10/3$  for rollers

$n$  = stroke frequency [double strokes/min]

$S_{\sin}$  = single stroke length [mm]

**NOTE:** The concept of rating life calculation is only valid in cases where the equivalent dynamic load  $P$  does not exceed 50 % of the dynamic load rating  $C$ . See also the indication for static calculation in **chapter 2.2.1**.

**NOTE:** The accuracy of the life calculation of a linear guide is enhanced by the correctness of the information about the load case and the known or calculable operating conditions.

**NOTE:** Lifetime calculation is related to the physical effect of fatigue of material. Fatigue is the result of shear stresses cyclically appearing immediately below the load carrying surface. After a time, these stresses cause cracks that gradually extend up to the surface. As the rolling elements pass over the crack, fragments of material break away. This process is known as flaking or spalling. This flaking progressively increases and eventually makes the bearing inoperable.



Several characteristics of the involved components affect the rating life of linear ball bearings (↳ **chapter 2.2.3**). To include these effects, the equation of rating life calculation is extended by 7 factors.

$$(7) \quad L_{ns} = 100 \cdot c_1 \cdot c_2 \cdot f_s \cdot \left( \frac{f_i \cdot f_h \cdot f_l \cdot f_m \cdot C}{F} \right)^3$$

where:

- $L_{ns}$  = modified basic rating life [km]
- $c_1$  = factor for reliability
- $c_2$  = factor for operating conditions
- $f_s$  = factor for stroke length
- $f_i$  = factor for the number of loaded bearings per shaft
- $f_h$  = factor for hardness of shaft
- $f_l$  = factor for direction of load
- $f_m$  = factor for misalignment
- $C$  = dynamic load rating [N]
- $F$  = bearing load [N]

Some characteristics of a linear guiding like:

- number of bearings (factor  $f_l$ )
- hardness of shaft (factor  $f_h$ )
- reliability of lifetime prediction (factor  $c_1$ )
- the operating conditions (factor  $c_2$ )

don't change during a certain application. So, related factors are constant for a particular calculation.

Other characteristics such as:

- length of stroke (factor  $f_s$ )
- load direction (factor  $f_l$ )
- misalignment between shaft and linear bearing (factor  $f_m$ )
- the applied load itself

might differ from load phase to load phase. With respect to that different behavior, the factors,  $f_s$ ,  $f_l$  and  $f_m$  will be applied in the denominator of the load.

$$(8) \quad L_{ns} = 100 \cdot c_1 \cdot c_2 \cdot \left( \frac{f_i \cdot f_h \cdot C}{F} \right)^3 = 100 \cdot c_1 \cdot c_2 \cdot \frac{(f_i \cdot f_h \cdot C)^3}{\left( \frac{F}{f_l \cdot f_m} \right)^3 \cdot \frac{1}{f_s}}$$

The range of values for all factors is between 0 and 1. So they either reduce the load rating by multiplication or increase the load by location in the denominator of the load.

## Service life

In addition to rating life, there also exists the concept of “service life”. This term describes the period of time a given linear bearing remains operational in a given set of operating conditions. Therefore, the service life of the bearing depends not necessarily on fatigue but also on

- wear,
- corrosion,
- failure of seals,
- lubrication intervals (grease life),
- misalignment between the shafts,
- vibration during standstill,
- etc.

Normally, the service life can only be quantified in tests under realistic operating conditions or by comparison with similar applications.

## Cross reference to related chapters

Details of the two dimensioning concepts presented in this chapter, static safety factor and basic rating life, are explained in the following chapters:

- **2.2.2 Calculation of bearing loads**
- **2.2.3 Factors of influence**
- **2.2.4 Elaborated equations for static safety and for the rating life**

## 2.2.2 Calculation of bearing loads

### Equivalent dynamic mean load

The rating life calculation formula assumes that the load and the speed are constant. In reality, the external loads, positions and speeds change in most cases and the workflow has to be separated into load phases with constant or approximately constant conditions along their individual strokes (↳ **diagram 5**). All single load phases are summarized to the equivalent dynamic mean load  $P_m$  depending on their individual stroke length (↳ **formulae 9 and 10**).

$$(9) \quad P_m = \sqrt[p]{\frac{\sum_{j=1}^V |P_j|^p \cdot S_j}{S_{tot}}}$$

$$(10) \quad S_{tot} = S_1 + S_2 + S_3 + \dots + S_j + \dots + S_v$$

where:

- $P_m$  = equivalent dynamic mean load [N]
- $P_j$  = equivalent dynamic load [N] during a particular load phase
- $j$  = counter for load phases
- $V$  = number of load phases
- $S_j$  = individual stroke length [mm] during a particular load phase
- $S_{tot}$  = total stroke length [mm]
- $p$  = life exponent;  $p = 3$  for balls,  $p = 10/3$  for rollers

The equivalent dynamic load  $P$  is calculated by the combined bearing load modulated by the factors for load direction and misalignment.

$$(11) \quad P_j = \frac{F_{comb,j}}{f_{l,j} \cdot f_{m,j}}$$

Applying that definition of the equivalent dynamic load  $P$ , the equivalent dynamic mean load  $P_m$  is calculated by

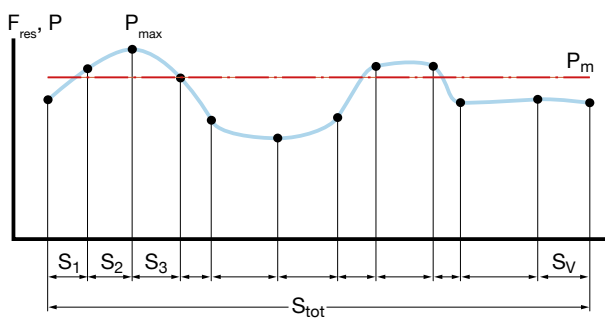
$$(12) \quad P_m = \sqrt[p]{\frac{\sum_{j=1}^V |P_j|^p \cdot S_j}{S_{tot}}} = \sqrt[p]{\frac{\sum_{j=1}^V \left| \left( \frac{F_{comb,j}}{f_{l,j} \cdot f_{m,j}} \right)^p \cdot S_j}{S_{tot}}}$$

where:

- $P_m$  = equivalent dynamic mean load [N]
- $P_j$  = equivalent dynamic load [N] during a particular load phase
- $j$  = counter for load phases
- $V$  = number of load phases
- $S_j$  = individual stroke length [mm] during a particular load phase
- $S_{tot}$  = total stroke length [mm]
- $p$  = life exponent;  $p = 3$  for balls,  $p = 10/3$  for rollers
- $F_{comb,j}$  = combined bearing load during a particular load phase [N]
- $f_{l,j}$  = factor for direction of load during a particular load phase
- $f_{m,j}$  = factor for misalignment during a particular load phase

Diagram 5

Variable load acting on a linear bearing



### Maximum equivalent load

If the maximum load occurs when linear guiding moves, the maximum value of  $P$  is required for calculating the static safety factor  $s_0$ . To this end, all loads must be calculated for the individual stroke lengths. With these figures, the maximum equivalent load  $P_{max}$  can be detected.

$P_0$ , the maximum static load during standstill is calculated by the similar formula. The maximum of both values  $P_0$  and  $P_{max}$  has to be applied in the equation for static safety factor  $s_0$ .

$$(13) \quad P_{max} = \frac{1}{f_{h,0}} \cdot \max_{j=1 \dots V} \left| \frac{F_{comb,j}}{f_{l,0,j} \cdot f_{m,j}} \right|$$

where:

- $P_0$  = maximum static load [N]
- $P_{max}$  = maximum equivalent load [N]
- $F_{comb,j}$  = combined bearing load during a load phase  $j$  [N]
- $f_{h,0}$  = static factor for hardness of shaft
- $f_{l,0,j}$  = static factor for direction of load during a load phase  $j$
- $f_{m,j}$  = factor for misalignment during a load phase  $j$
- $j$  = counter for load phases
- $V$  = number of load phases

## Combined bearing loads

The combined bearing load for linear ball bearings combines the load vectors at the bearing point  $F_y$  and  $F_z$  and the absolute value of the combined bearing load is calculated by Pythagoras of  $F_y$  and  $F_z$ .

$$(14) \quad F_{\text{comb}} = \sqrt{F_y^2 + F_z^2}$$

where:

- $F_{\text{comb}}$  = combined bearing load [N]
- $F_y$  = bearing load in y-direction [N]
- $F_z$  = bearing load in z-direction [N]

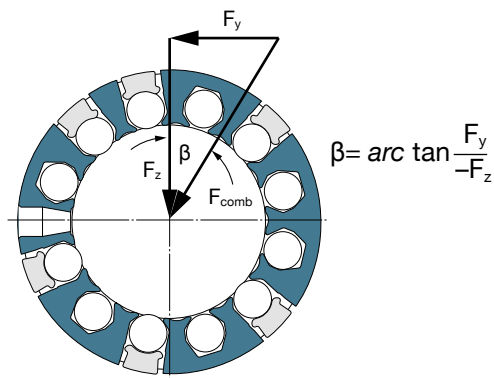
The direction of the combined bearing load expressed as angle beta relative to the z-axis of the coordinate system can be calculated by the inverse tangent function ( $\hookrightarrow$  **fig. 1**).

$$(15) \quad \beta = \arctan \frac{F_y}{-F_z} \quad \text{for } -\infty < \frac{F_y}{-F_z} < \infty$$

where:

- $F_{\text{comb}}$  = combined bearing load [N]
- $F_y$  = bearing load in y-direction [N]
- $F_z$  = bearing load in z-direction [N]

Fig. 1

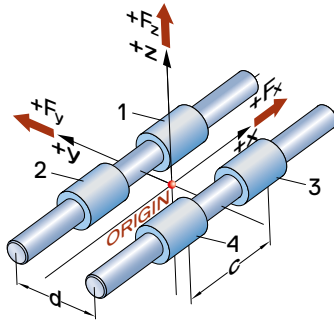


## Translation of external forces to loads at the bearing point

The calculation formulae for determining the loads at the linear bearings are shown in **figures 2, 3 and 4**.

Fig. 2

Loads on a system with 2 shafts and 4 linear bearings (configuration 24)



Bearing point	Formula
Load at the bearing point: Force in y-direction	
1/3	$F_{y1} = F_{y3} = \frac{\sum_{i=1}^U F_{y,i}}{4} - \frac{\sum_{i=1}^U (F_{x,i} \cdot y_i) - \sum_{i=1}^U (F_{y,i} \cdot x_i)}{2 \cdot c}$
2/4	$F_{y2} = F_{y4} = \frac{\sum_{i=1}^U F_{y,i}}{4} + \frac{\sum_{i=1}^U (F_{x,i} \cdot y_i) - \sum_{i=1}^U (F_{y,i} \cdot x_i)}{2 \cdot c}$
Load at the bearing point: Force in z-direction	
1	$F_{z1} = \frac{\sum_{i=1}^U F_{z,i}}{4} - \frac{\sum_{i=1}^U (F_{x,i} \cdot z_i) - \sum_{i=1}^U (F_{z,i} \cdot x_i)}{2 \cdot c} - \frac{\sum_{i=1}^U (F_{y,i} \cdot z_i) - \sum_{i=1}^U (F_{z,i} \cdot y_i)}{2 \cdot d}$
2	$F_{z2} = \frac{\sum_{i=1}^U F_{z,i}}{4} + \frac{\sum_{i=1}^U (F_{x,i} \cdot z_i) - \sum_{i=1}^U (F_{z,i} \cdot x_i)}{2 \cdot c} - \frac{\sum_{i=1}^U (F_{y,i} \cdot z_i) - \sum_{i=1}^U (F_{z,i} \cdot y_i)}{2 \cdot d}$
3	$F_{z3} = \frac{\sum_{i=1}^U F_{z,i}}{4} - \frac{\sum_{i=1}^U (F_{x,i} \cdot z_i) - \sum_{i=1}^U (F_{z,i} \cdot x_i)}{2 \cdot c} + \frac{\sum_{i=1}^U (F_{y,i} \cdot z_i) - \sum_{i=1}^U (F_{z,i} \cdot y_i)}{2 \cdot d}$
4	$F_{z4} = \frac{\sum_{i=1}^U F_{z,i}}{4} + \frac{\sum_{i=1}^U (F_{x,i} \cdot z_i) - \sum_{i=1}^U (F_{z,i} \cdot x_i)}{2 \cdot c} + \frac{\sum_{i=1}^U (F_{y,i} \cdot z_i) - \sum_{i=1}^U (F_{z,i} \cdot y_i)}{2 \cdot d}$

where:

$F_{y1}, F_{y2}, F_{y3}, F_{y4}$  = bearing load in y-direction at bearing No. 1, No. 2, No. 3 and No. 4 [N]

$F_{z1}, F_{z2}, F_{z3}, F_{z4}$  = bearing load in z-direction at bearing No. 1, No. 2, No. 3 and No. 4 [N]

$F_{x,i}, F_{y,i}, F_{z,i}$  = external loads in x-, y- and z-direction [N]

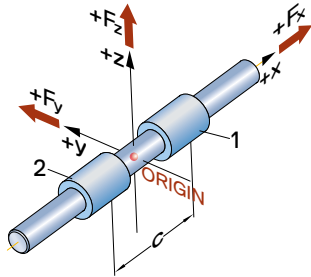
$x_i, y_i, z_i$  = lever arms of external loads [mm]

$i$  = counter for external loads

$U$  = number of loads that act simultaneously

Fig. 3

Loads on a system with 1 shaft and 2 linear bearings (configuration 12)



Bearing point	Formula
Load at the bearing point: Force in y-direction	
1	$F_{y1} = \frac{\sum_{i=1}^U F_{y,i}}{2} - \frac{\sum_{i=1}^U (F_{x,i} \cdot y_i) - \sum_{i=1}^U (F_{y,i} \cdot x_i)}{c}$
2	$F_{y2} = \frac{\sum_{i=1}^U F_{y,i}}{2} + \frac{\sum_{i=1}^U (F_{x,i} \cdot y_i) - \sum_{i=1}^U (F_{y,i} \cdot x_i)}{c}$
Load at the bearing point: Force in z-direction	
1	$F_{z1} = \frac{\sum_{i=1}^U F_{z,i}}{2} - \frac{\sum_{i=1}^U (F_{x,i} \cdot z_i) - \sum_{i=1}^U (F_{z,i} \cdot x_i)}{c}$
2	$F_{z2} = \frac{\sum_{i=1}^U F_{z,i}}{2} + \frac{\sum_{i=1}^U (F_{x,i} \cdot z_i) - \sum_{i=1}^U (F_{z,i} \cdot x_i)}{c}$
Load at the bearing point: Moment about x-axis	
1/2	$M_{x1} = M_{x2} = \frac{-\sum_{i=1}^U (F_{y,i} \cdot z_i) + \sum_{i=1}^U (F_{z,i} \cdot y_i)}{2}$

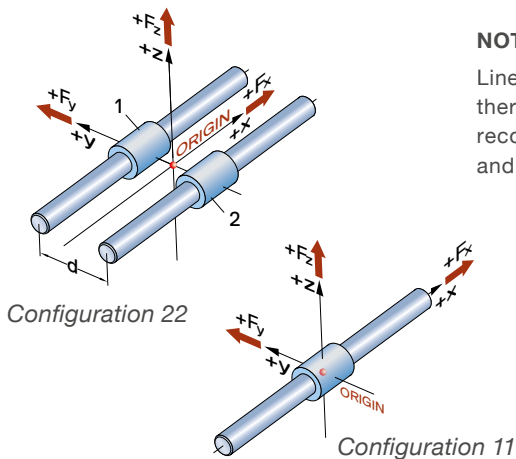
**NOTE:**

As linear ball bearings can't carry load about the x-axis, configuration 12 is feasible only if  $M_x=0$  by the external loads itself or by additional measures.

where:

- $F_{y1}, F_{y2}$  = bearing load in y-direction at bearing No. 1 and No. 2 [N]
- $F_{z1}, F_{z2}$  = bearing load in z-direction at bearing No. 1 and No. 2 [N]
- $M_{x1}, M_{x2}$  = bearing torque load about x-axis [Nmm]
- $F_{x,i}, F_{y,i}, F_{z,i}$  = external loads in x-, y- and z-direction [N]
- $x, y, z$  = lever arms of external loads [mm]
- $i$  = counter for external loads
- $U$  = number of loads that act simultaneously

Fig. 4



**NOTE:**

Linear ball bearings are sensitive regarding edge stress and therefore they can't cover torque loads  $M_y$  and  $M_z$ . It isn't recommended to use linear ball bearings in configurations 11 and 22.

## 2.2.3 Factors of influence

### Requisite reliability, factor $c_1$

The factor  $c_1$  is used in the calculation of bearing life in cases where the intended prediction of reliability has to exceed 90 %. The corresponding values for  $c_1$  are given in **table 8**.

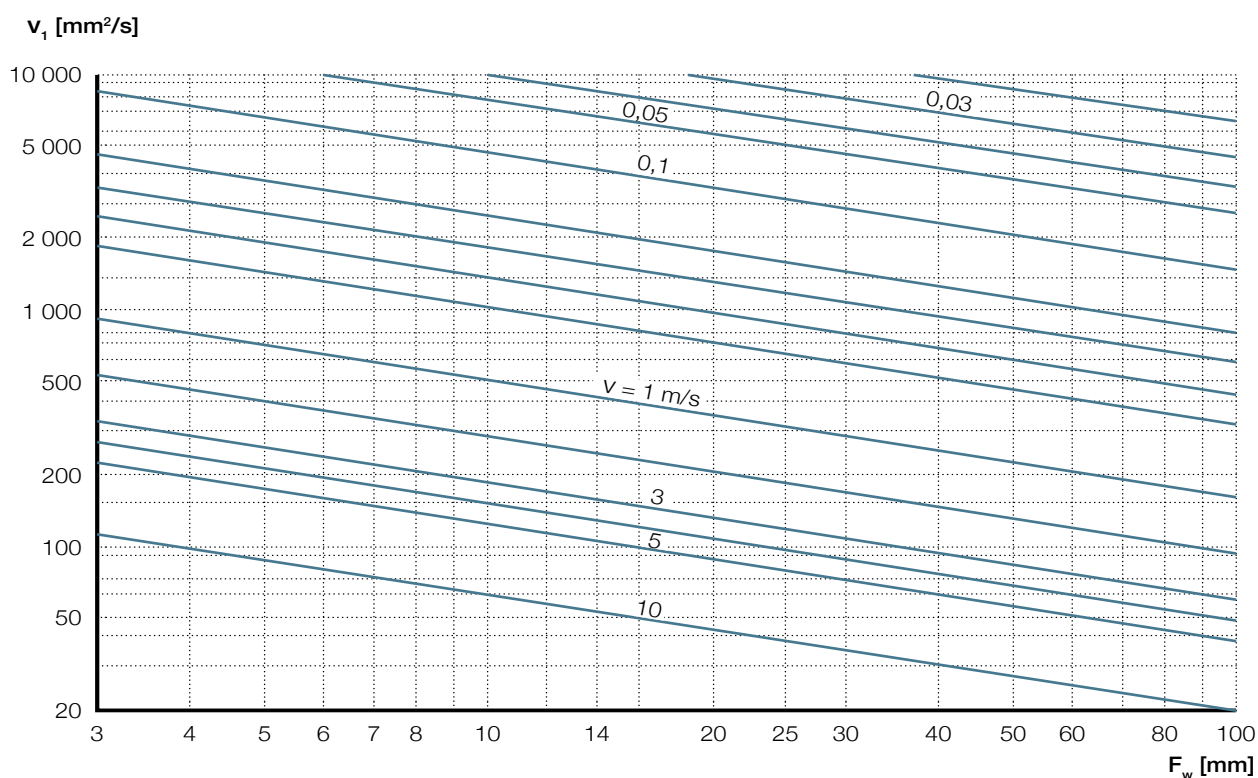
Table 8

Factor  $c_1$  for reliability

Reliability %	$L_{ns}$	$c_1$
90	$L_{10s}$	1
95	$L_{5s}$	0,62
96	$L_{4s}$	0,53
97	$L_{3s}$	0,44
98	$L_{2s}$	0,33
99	$L_{1s}$	0,21

Diagram 6

Requisite kinematic viscosity  $v_1$  at operating temperature



### Operating conditions, factor $c_2$

The lubrication effectiveness is strongly dependent on the degree of separation between the steel balls and raceway surfaces in the contact zones. A specific minimum viscosity is required for the formation of an effective separating lubricating film at operating temperature, considering the kinematic conditions. Assuming a normal level of cleanliness of the guide shaft as well as effective sealing, factor  $c_2$  depends on the viscosity ratio  $\kappa$  exclusively.  $\kappa$  designates the ratio between the actual kinematic viscosity  $v$  and the requisite minimum viscosity  $v_1$  (→ **formula 16**), each at operating temperature.

$$(16) \quad \kappa = \frac{v}{v_1}$$

where:

- $\kappa$  = viscosity ratio
- $v$  = actual kinematic viscosity at operating temperature [mm<sup>2</sup>/s]
- $v_1$  = requisite minimum viscosity at operating temperature [mm<sup>2</sup>/s]

The requisite minimum viscosity  $v_1$  in relation to the mean speed  $v$  and the shaft diameter  $F_w$  is shown in **diagram 6**. The diagram is valid for additive-free mineral oils and for lubricating greases with mineral base oils. The diagram represents the required viscosity of the base oil at operating temperature.

**Diagram 7** transfers a kinematic viscosity at operating temperature to the viscosity at the international standard temperature of 40 °C. A single graph represents a lubricant with a certain kinematic viscosity at 40 °C. So if for example, the requisite kinematic viscosity is 100 mm<sup>2</sup>/s according to **diagram 6** and the operating temperature is 70 °C, the kinematic viscosity at 40 °C is 460 mm<sup>2</sup>/s. The red arrows in **diagram 7** represent this example.

After identifying the viscosity ratio  $\kappa$ ,  $c_2$  can be taken from **diagram 8**. If  $\kappa$  is less than 1, a lubricant with extreme pressure (EP) additives is recommended. If it is less than 0,4, the use of EP additives is essential. If lubricants with EP additives are used, the higher value for  $c_2$  from the diagram can be used for calculation. Linear ball bearings from Ewellix are factory pre-lubricated with LGEP 2 grease that contains EP additives (→ **chapter 4.3**).

**NOTE:** If greases other than standard grease LGEP 2 are used, make sure that the grease and especially the EP additives are compatible with the linear bearing materials.



Diagram 7

Lubricant viscosity  $v$  vs. temperature

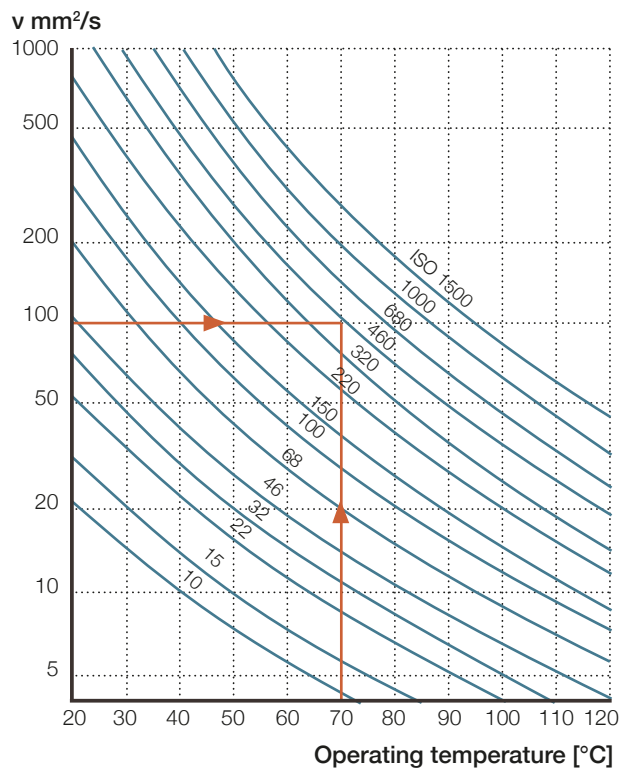
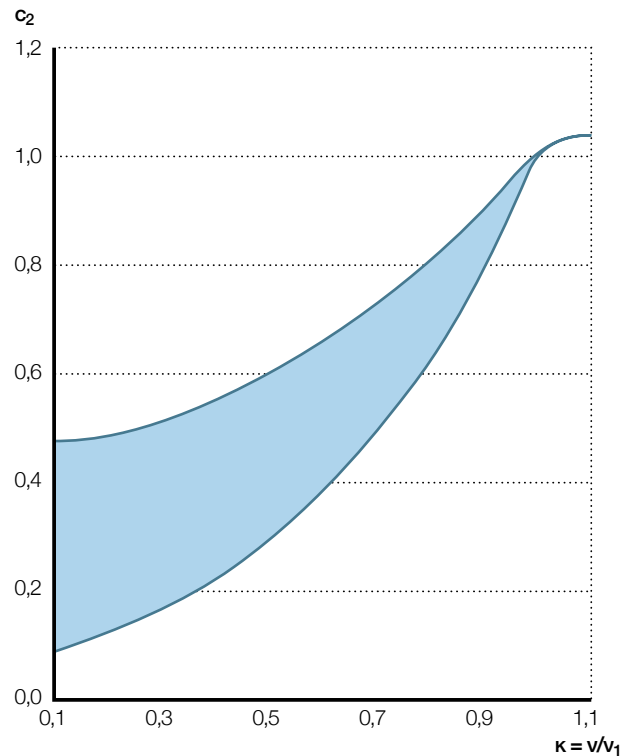


Diagram 8

Factor  $c_2$  for operating conditions



### Number of loaded bearings per shaft, factor $f_i$

Most linear ball bearing configurations feature two (or more) bearings mounted on one shaft. The load distribution on these various bearings is strongly influenced by

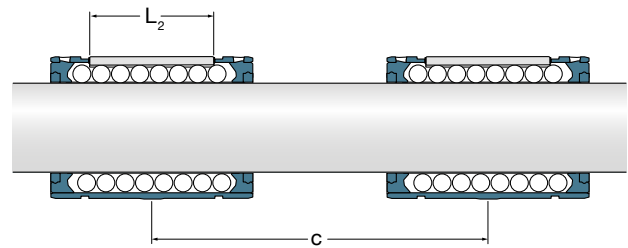
- the mounting accuracy,
- the manufacturing quality of the adjacent components, and in particular,
- the distance between the bearings.

Factor  $f_i$  takes these influences on bearing loading into account based on the number of bearings per shaft and the distance between them (→ **table 9**). The raceway lengths  $L_2$  of the various types of linear ball bearings are listed in **table 10**.

**NOTE:** This factor has no influence when the bearings are mounted in the same accurate drilling as used in the original housings from Ewellix (for design rules, please see **chapter 4.1.2**).

Table 9

Factor  $f_i$  for number of loaded bearings per shaft



Number of bearings	If $c \geq 1,5 L_2$	If $c < 1,5 L_2$
	$f_i$	$f_i$
1	1	1
2	1	0,81
3	1	0,72

Table 10

Raceway length  $L_2$  of the various linear ball bearings

Size $F_w$ mm	Compact range			Standard range				$L_2$ mm	Type	$L_2$ mm	Type	$L_2$ mm
	Type	$L_2$ mm	Type	Type	Type	Type	Type					
3	LBBR	4,1	-	-	-	-	-	-	-	-	-	-
4	LBBR	5,4	-	-	-	-	-	-	-	-	-	-
5	LBBR	7,1	LBCR	-	-	-	11,3	-	-	-	-	11,3
6	LBBR	12	-	-	-	-	-	-	-	-	-	-
8	LBBR	12,7	LBCR	-	-	-	12,5	-	-	-	-	12,5
10	LBBR	12,7	-	-	-	-	-	-	-	-	-	-
12	LBBR	15,4	LBCR	LBCD	LBCT	LBCF	18,4	-	-	-	-	18,4
14	LBBR	15,4	-	-	-	-	-	-	-	-	-	-
16	LBBR	15,4	LBCR	LBCD	LBCT	LBCF	21,2	-	-	-	-	21,2
20	LBBR	15,4	LBCR	LBCD	LBCT	LBCF	27,6	LBHT	-	-	-	27,8
25	LBBR	22,4	LBCR	LBCD	LBCT	LBCF	37,2	LBHT	LBCT A	LBCF A	-	39,6
30	LBBR	32	LBCR	LBCD	LBCT	LBCF	45,4	LBHT	-	-	-	47,7
40	LBBR	38,6	LBCR	LBCD	LBCT <sup>u)</sup>	LBCF <sup>u)</sup>	50,8	LBHT	LBCT A	LBCF A	-	54
50	LBBR	47,8	LBCR	LBCD	LBCT	LBCF	68,5	LBHT	-	-	-	68,5
60	-	-	LBCR	-	LBCT	-	92	-	-	-	-	92
80	-	-	LBCR	-	LBCT	-	122	-	-	-	-	122

<sup>u)</sup> Size 40 under development; A-design linear ball bearing is available until replacement



## Impact of stroke length, factor $f_s$

Strokes shorter than the raceway length of the linear ball bearing have a negative influence on the achievable life of a guiding system. Based on the ratio of the single stroke length  $S$  or, if there are several load phases with the identical moving direction, the sub stroke length  $S_s$  relative to raceway length  $L_2$  (→ **table 10**), factor  $f_s$  is determined according to **table 11**.

Sequenced load phases with identical moving direction deliver a sub stroke length ( $S_s$ ) according to **formula 17** to determine  $f_s$ .

$$(17) \quad S_s = \sum_{j=A}^B S_j$$

where:

- $S_s$  = sub stroke length [mm]
- $S_j$  = individual stroke length of a load phase [mm]
- $j$  = counter for load phases (A, A+1, A+2, . . . , B)
- A = starting point of movement in one direction
- B = next reversal point

**Table 11**

Factor  $f_s$  depending on ratio  $S/L_2$  or  $S_s/L_2$

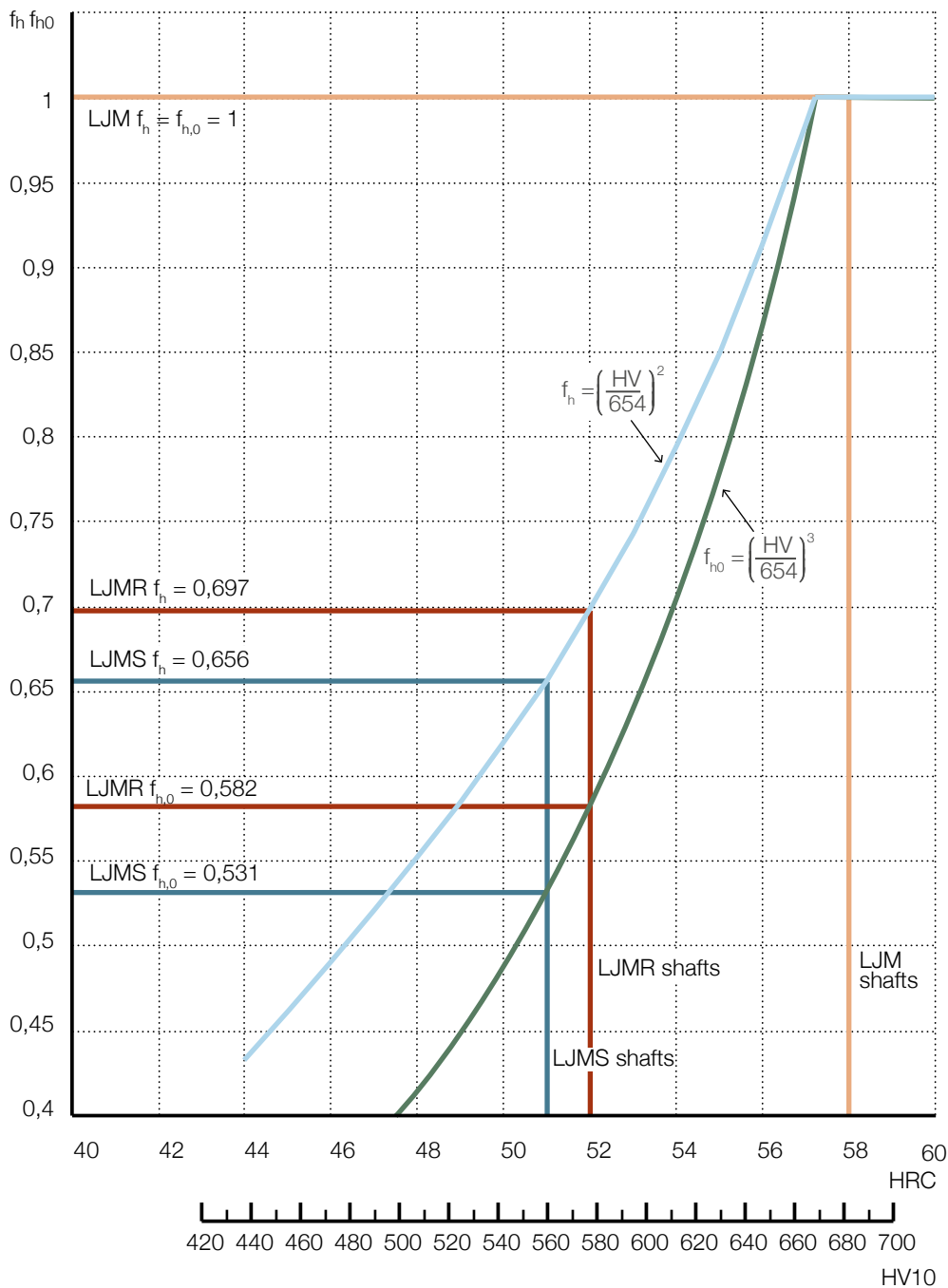
$S/L_2$ $S_s/L_2$	$f_s$
1,0	1,00
0,9	0,91
0,8	0,82
0,7	0,73
0,6	0,63
0,5	0,54
0,4	0,44
0,3	0,34
0,2	0,23
0,1	0,13

**Influence of shaft hardness, factors  $f_h, f_{h,0}$**

The full load rating of the linear ball bearing will be reached in conjunction with shaft of hardness  $\geq 58\text{HRC}$ . For shafts with lower hardness, e.g. shafts from stainless steel, the factor  $f_{h,0}$  reduces the static load rating  $C_0$  and the factor  $f_h$  reduces the dynamic load rating  $C$ . For shafts with hardness  $< 44 \text{ HRC}$  (430 HV), please consult Ewellix.

Diagram 9

Factor for hardness of shaft



### Influence of misalignment, factor $f_m$

As described in **chapter 2.1.3**, loads on unsupported shafts cause deflection and therefore the shaft and the linear ball bearings are misaligned under load. **Table 12** shows the consequences to static safety and lifetime calculations depending on bearing type and degree of misalignment.

**Diagram 10** illustrates the function

$$f_m = f(\alpha) = f(\text{misalignment}).$$

As loads differ between load phases, the factor  $f_m$  is phase-sensitive and therefore applied in the denominator of the load in the equation of static safety and rating life calculation.

Table 12

Impact of misalignment between shaft and various types of linear ball bearings

Bearing type	Misalignment <sup>1)</sup>	$f_m$	Consequence
Rigid LBBR, LBCR, LBCT, LBHT	$\alpha \leq \pm 5'$	= 1	full static safety and rating life
	$\pm 5' < \alpha \leq 15'$	= $1,04 + \alpha \cdot (0,006 - 0,0028 \cdot \alpha)$ <sup>1)</sup>	reduced static safety and rating life
	$\pm 15' < \alpha$	= 0	out of valid range
Self-aligning LBCD, LBCF	$\alpha \leq \pm 30'$	= 1	full static safety and rating life
	$\pm 30' < \alpha$	= 0	out of valid range

<sup>1)</sup>  $\alpha$  in minutes of arc;  $30' = 30$  minutes of arc =  $0,5^\circ$

Diagram 10

Factor for misalignment

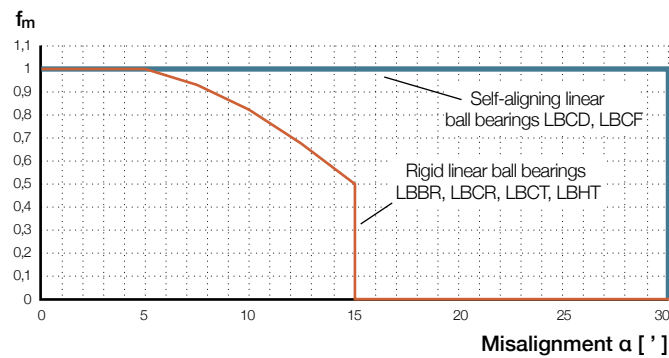


Table 13

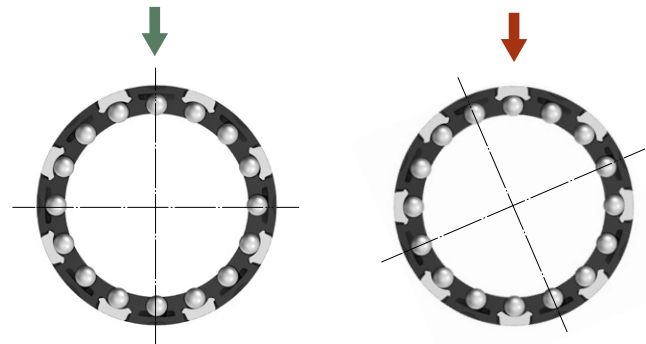
### Influence of direction of load, factors $f_1, f_{1,0}$

The static and the dynamic load rating vary around the center axis of the linear ball bearing.

Bearings of our compact range (LBB) have a relative small deviation between  $C_{0,min}$  and  $C_{0,max}$ , respectively  $C_{min}$  and  $C_{max}$ . The minimums and the maximums are distributed equidistantly based on the location of raceway plates. Typically, the direction of maximal load rating  $C_{0,max}$  and  $C_{max}$  is between the raceway plates. Divergent from that rule are the directions of max. dynamic load rating of sizes 25, 30 and 40 at the raceway plates (→ table 13).

Bearings of the standard range (LBC) have a concentration of raceway plates and therefore a direction of maximum load rating, which is indicated by arrow (Design D) or hatch surface (Design A) at the face side of linear ball bearing. The deviation between  $C_{0,min}$  and  $C_{0,max}$ , respectively  $C_{min}$  and  $C_{max}$  is significant. For details, see diagram 11 to 15, that also show the dependency from load angle.

Direction of max. load rating for LBB bearings



	Static	Dynamic
	$C_{0,max}$	$C_{max}$
Between the raceway plates ↓	All sizes	Sizes 3 to 20 and 50
At the raceway plates ↓		Sizes 25, 30, 40

Diagram 11

Factors  $f_1$  and  $f_{1,0}$  related to the direction of load for LBCR and LBCD linear ball bearings of the D-series

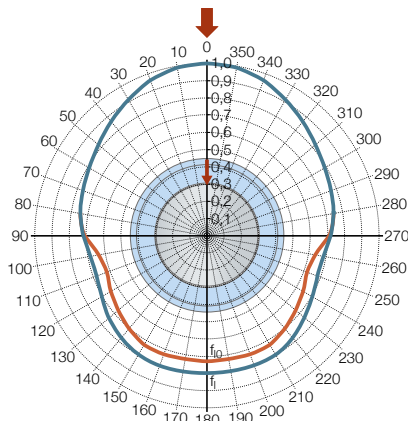


Diagram 13

Factors  $f_1$  and  $f_{1,0}$  related to the direction of load for LBCR and LBCD A-series linear ball bearings

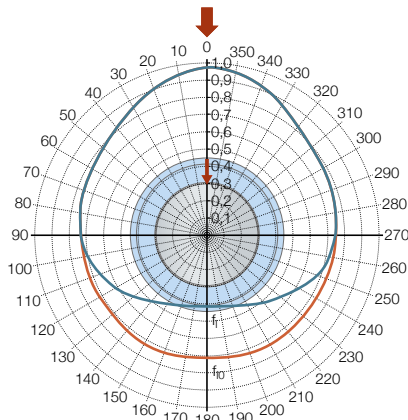


Diagram 12

Factor  $f_1$  and  $f_{1,0}$  related to the direction of load for LBCT and LBCF linear ball bearings of the D-series

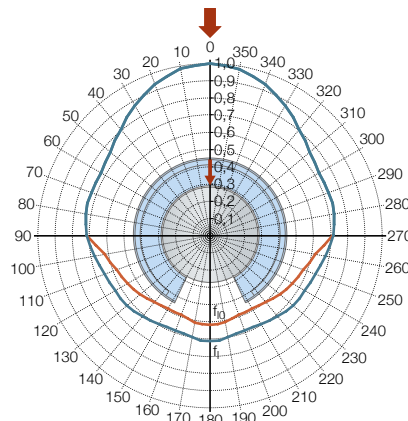


Diagram 14

Factor  $f_1$  and  $f_{1,0}$  related to the direction of load for LBCT and LBCF A-series linear ball bearings

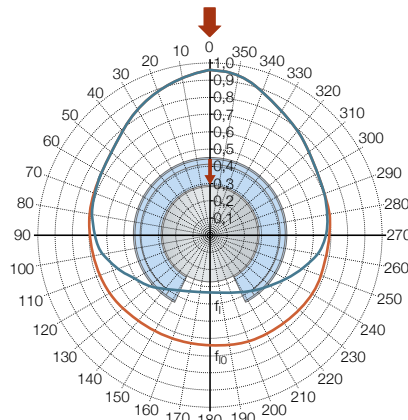
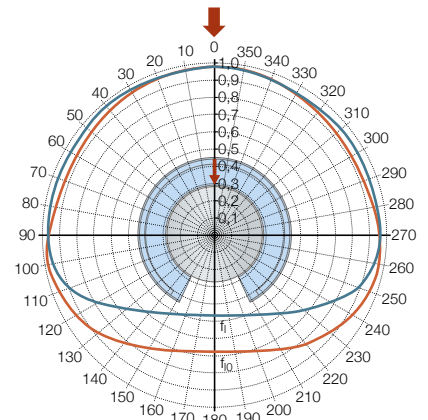


Diagram 15

Factor  $f_1$  and  $f_{1,0}$  related to the direction of load for LBHT linear ball bearings



**NOTE:**

Definition of minimum load ratings for standard range bearings:

$$C_{min} = C_{max} \cdot f_1 \text{ for } f_1 \text{ at } 180^\circ$$

$$C_{0,min} = C_{0,max} \cdot f_{1,0} \text{ for } f_{1,0} \text{ at } 180^\circ$$

The varying load ratings of linear ball bearings around their center axis have to be considered in the design and selection process of linear guidings. For easier decision making, see **table 14**.

Table 14

Options for orientation of a linear ball bearing during the mounting process

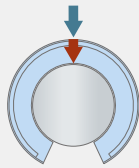
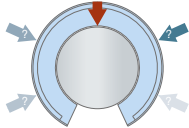
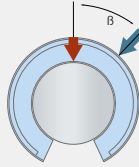
	Defined orientation	Random orientation
Benefit	Offers the potential to align direction of main load and max. load rating. Therefore, the full load rating of the linear ball bearing can be utilized	Less effort during series mounting
Compromise	Slightly higher effort during series mounting	Only the values $C_{0,min}$ & $C_{min}$ could be applied during dimensioning calculation and more importantly, in a real application, you can rely on only the minimum load rating.



The impact of the following circumstances on the calculations is described in **table 15**:

- the characteristic of linear ball bearings (→ **diagram 11 to 15**) or
- the direction of acting load  $F_j$  for that particular load phase or in total (factors  $f_i$ ) and
- the mounting status

Table 15

Load direction to be considered for the calculation of static safety and rating life

The load direction at that load phase and the direction of max. load rating are	Values to be applied for calculation of static safety		rating life	
coincident 	$F_{comb,max} / f_{m,j}$	$C_{0,max}$	$F_{comb,j} / f_{m,j}$	$C_{max}$
unknown 	$F_{comb,max} / f_{m,j}$	$C_{0,min}$	$F_{comb,j} / f_{m,j}$	$C_{min}$
known, but differs 	<b>For compact series LBB</b>			
	$F_{comb,max} / f_{m,j}$	$C_{0,min}$	$F_{comb,j} / f_{m,j}$	$C_{min}$
	<b>For standard series LBC</b>			
	$\max_{j=1 \rightarrow V} \left  \frac{F_{comb,j}}{f_{i,0,j} \cdot f_{m,j}} \right $	$C_{0,max}$	$F_{comb,j} / (f_{i,j} \cdot f_{m,j})$	$C_{max}$

 Direction of load  
 Direction of max. load rating

As loads and their direction differ between load phases, the factor  $f_{i,0}$  and  $f_i$  is phase-sensitive and therefore applied in the denominator of the load in the equation of static safety and rating life calculation.

## 2.2.4 Elaborated equations for the static safety factor and for the rating life

### Elaborated equation for the static safety factor

All given equations related to the static safety factor can be integrated into one formula:

$$(18) \quad s_0 = \frac{C_0}{P_{\max}} = \frac{f_{h,0} \cdot C_0}{\max_{j=1 \rightarrow V} \left| \frac{F_{\text{comb},j}}{f_{l,0,j} \cdot f_{m,j}} \right|} = \frac{f_{h,0} \cdot C_0}{\max_{j=1 \rightarrow V} \left| \frac{\sqrt{F_{y,j}^2 + F_{z,j}^2}}{f_{l,0,j} \cdot f_{m,j}} \right|} \quad \text{or} \quad s_0 = \frac{C_0}{P_0}$$

### Elaborated equation for the modified basic rating life

All given equations related to the rating life calculation can be integrated into one formula:

$$(19) \quad L_{\text{ns}} = 100 \cdot \left( \frac{C}{P} \right)^p = 100 \cdot c_1 \cdot c_2 \cdot \left( \frac{f_i \cdot f_h \cdot C}{F} \right)^p = 100 \cdot c_1 \cdot c_2 \cdot \frac{(f_i \cdot f_h \cdot C)^p}{\left( \frac{F}{f_l \cdot f_m} \right)^p \cdot \frac{1}{f_s}}$$

$$(20) \quad L_{\text{ns}} = 100 \cdot c_1 \cdot c_2 \cdot \frac{(f_i \cdot f_h \cdot C)^p}{\sum_{j=1}^V \left| \left( \frac{F_{\text{comb},j}}{f_{l,j} \cdot f_{m,j}} \right)^p \cdot S_j \right|} \cdot \frac{1}{S_{\text{tot}} \cdot \frac{1}{f_{s,j}}} = 100 \cdot c_1 \cdot c_2 \cdot \frac{S_{\text{tot}} \cdot (f_i \cdot f_h \cdot C)^p}{\sum_{j=1}^V \left| \left( \frac{F_{\text{comb},j}}{f_{l,j} \cdot f_{m,j}} \right)^p \cdot \frac{S_j}{f_{s,j}} \right|}$$

$$(21) \quad L_{\text{ns}} = 100 \cdot c_1 \cdot c_2 \cdot \frac{S_{\text{tot}} \cdot (f_i \cdot f_h \cdot C)^p}{\sum_{j=1}^V \left| \left( \frac{\sqrt{F_{y,j}^2 + F_{z,j}^2}}{f_{l,0,j} \cdot f_{m,j}} \right)^p \cdot \frac{S_j}{f_{s,j}} \right|}$$

## 2.2.5 Calculation example

### Description of the application

A Quadro linear bearing unit LQCD 20-2LS consisting of 4 linear ball bearings LBCD 20-2LS with closed housing can support a load of 400 N which is constant in magnitude and direction and which acts vertically and centrally whilst operating at a stroke frequency of 30 min<sup>-1</sup> and a stroke length of 600 mm. LJMR shafts from stainless steel X90CrMoV18 are used. The solid shaft is secured in two tandem shaft blocks.

The shaft length between the two tandem shaft blocks is 1 000 mm. The linear ball bearings are lubricated with SKF grease LGEP 2 which has a base oil viscosity of 200 mm<sup>2</sup>/s at 40 °C. The maximum operating temperature is assumed to be 40 °C.

What are the values of the adjusted rating life, static safety and stiffness of the system?

### Loads at the bearing point

As the external load is applied centrally and therefore equally distributed between the 4 bearings, the full set of formulae given in **chapter 2.2.2** paragraph *Translation of external forces to loads at the bearing point* could be simplified:

$$(22) \quad F_{z1} = F_{z2} = F_{z3} = F_{z4} = \frac{F_{z, \text{external}}}{4} = \frac{400 \text{ N}}{4} = 100 \text{ N}$$

$$(23) \quad F_{y1} = F_{y2} = F_{y3} = F_{y4} = \frac{F_{y, \text{external}}}{4} = \frac{0 \text{ N}}{4} = 0 \text{ N}$$

### Combined bearing loads

Thus the value of the combined bearing loads is identical for all 4 bearings:

$$(24) \quad F_{\text{comb1}} = F_{\text{comb2}} = F_{\text{comb3}} = F_{\text{comb4}} = \sqrt{F_y^2 + F_z^2} = \sqrt{(100 \text{ N})^2 + (0 \text{ N})^2} = 100 \text{ N}$$

### Calculation of misalignment, caused by bending of the shaft under load

The factor of misalignment impacts adjusted rating life as well as the static safety factor. For preparation of both dimensioning methods, the angle of misalignment between bended shaft and linear ball bearings must be calculated. The total misalignment is the sum of misalignment under the weight of the shaft and with two symmetrical loads at distance l-2a. See **diagram 4**.

Values of input:

F	= 100 N	= bearing load, [N]
d	= 20 mm	= shaft diameter
d <sub>i</sub>	= 0 mm	= inner diameter of hollow shaft; d <sub>i</sub> = 0 means solid shaft
l	= 1 000 mm	= shaft length between clamped ends
L-C	= 130 – 45 mm = 85 mm	= distance between center of linear ball bearings in LQCD 20
a	= [l-(L-C)]/2	= distance between clamping and point of application of load
	= (1 000 mm – 85 mm)/2	= distance between clamping of shaft and middle of first linear ball bearing
	= 457,5 mm	

Misalignment of clamped shaft

$$(25) \quad \alpha_{\text{ges}} = \alpha_{\text{EG}} + \alpha_{\text{EL}} = \frac{1,71 \cdot 10^{-6} \cdot a \cdot (l^2 + 2 \cdot a^2 - 3 \cdot a \cdot l)}{d^2} + \frac{0,17 \cdot F \cdot a^2 \cdot \left(1 - 2 \cdot \frac{a}{l}\right)}{d^4}$$

$$(26) \quad \alpha_{\text{ges}} = \frac{1,71 \cdot 10^{-6} \cdot 457,5 \cdot (1\,000^2 + 2 \cdot 457,5^2 - 3 \cdot 457,5 \cdot 1\,000)}{20^2} + \frac{0,17 \cdot 100 \cdot 457,5^2 \cdot \left(1 - 2 \cdot \frac{457,5}{1\,000}\right)}{20^4}$$

$$(27) \quad \alpha_{\text{ges}} = 0,09' + 1,89' = 1,98' \text{ (minute of arc)}$$

**NOTE:** The misalignment under its own weight and the applied load is below the limit value of 5'. Below this limit, the factor for misalignment  $f_m = 1$  and therefore the equivalent bearing load isn't increased for non-self-aligning linear ball bearings.

**Factors of influence**

In order to calculate the rating life and static safety, the complete set of factors must be defined:

**Factor  $c_1$  for reliability**

Since no specific reliability was called for,

$$c_1 = 1$$

for a rating life achieved or exceeded by 90 % of the bearings (↳ **table 8**)

**Factor  $c_2$  for operating conditions**

From the stroke length and number of strokes per minute, the mean velocity is

$$(28) \quad v = 2 \cdot s \cdot \frac{n}{60 \frac{s}{min}} = 2 \cdot 600 \text{ mm} \cdot \frac{30 \frac{1}{min}}{60 \frac{s}{min}} = 600 \frac{mm}{s} = 0,6 \frac{m}{s}$$

Using the **diagram 6** for the determination of the requisite minimum viscosity for a linear ball bearing of size 20 operating at a mean velocity of 0,6 m/s, a lubricant having  $v_1 = 600 \text{ mm}^2/\text{s}$  should be used.

An operating temperature not exceeding 40 °C is assumed. The grease used has a base oil viscosity of 200  $\text{mm}^2/\text{s}$  at the operating temperature. Thus:

$$(29) \quad \kappa = \frac{v}{v_1} = \frac{200 \frac{mm^2}{s}}{600 \frac{mm^2}{s}} = 0,33$$

In this case, **diagram 8** shows a factor  $c_2$  of between 0,18 and 0,6. The lower value applies to mineral oils without additives and the upper value to mineral oils with approved EP additives. As SKF greases are subjected to constant quality control, their properties in terms of extended bearing life can be relied upon. Thus:

$$(30) \quad c_2 = 0,6$$

**Factor  $f_i$  for the number of loaded bearings per unit**

This factor has already been taken into consideration in the dynamic load ratings quoted for Ewellix linear bearing units, therefore  $f_i = 1$

**Factor for stroke length**

The ratio of stroke length to length of raceway plates is

$$(31) \quad \frac{S}{L_2} = \frac{600 \text{ mm}}{27,6 \text{ mm}} = 21,7$$

and thus, according to **table 11**:  $f_s = 1$

**Factors  $f_h$  and  $f_{h,0}$  for surface hardness of shaft**

According to **diagram 9**,  $f_h = 0,69$  and  $f_{h,0} = 0,582$  for LJMR shafts

**Factors  $f_l$  and  $f_{l,0}$  for direction of load**

Since the line of load acts through the zone of maximum load rating of the linear ball bearing,  $f_l$  and  $f_{l,0} = 1$ ,

**Factor  $f_m$  for misalignment**

Since previous calculation of misalignment shows that the upper limit of misalignment

$$\alpha_{ges} < 5' = 5 \text{ minutes of arc.}$$

Consequently according to **diagram 10**:

$$f_m = 1$$



### Calculation of rating life

Values of input:

- $F_{\text{external}} = 400 \text{ N}$  = external load
- $C = 7\,200 \text{ N}$  = dynamic load rating of Quadro unit LQCD 20-2LS
- $C_0 = 6\,700 \text{ N}$  = basic static load rating of Quadro unit LQCD 20-2LS
- $c_1, c_2, f_s, f_i, f_h, f_{h,0}, f_l, f_{l,0}, f_m$  From previous paragraph

With prepared data the rating life becomes:

$$(32) \quad L_{ns} = 100 \cdot c_1 \cdot C_2 \cdot \frac{(f_i \cdot f_h \cdot C)^3}{\left(\frac{F}{f_i \cdot f_m}\right)^3 \cdot \frac{1}{f_s}}$$

$$(33) \quad L_{l,0} = 100 \cdot 1 \cdot 0,6 \cdot \frac{(1 \cdot 0,69 \cdot 6\,700 \text{ N})^3}{\left(\frac{400 \text{ N}}{1 \cdot 1}\right)^3 \cdot \frac{1}{1}} = 60 \cdot \left(\frac{0,69 \cdot 6\,700 \text{ N}}{400 \text{ N}}\right)^3 = 92\,630 \text{ km}$$

### Calculation of static safety

With prepared data the static safety factor becomes:

$$(34) \quad S_0 = \frac{C_0}{P_0} = \frac{C_0}{P_{\max}} = \frac{f_{h,0} \cdot C_0}{\max_{j=1 \rightarrow V} \left| \frac{f_{\text{comb},j}}{f_{l,0,j} \cdot f_{m,j}} \right|} = \frac{0,582 \cdot 7\,200 \text{ N}}{\max_{j=1 \rightarrow V} \left| \frac{400 \text{ N}}{1 \cdot 1} \right|} = \frac{0,582 \cdot 7\,200 \text{ N}}{400 \text{ N}} = 10,5$$

Because of the high static load safety, it can be assumed that the operation of the bearing unit will not be impaired through load-related mechanical deformation.

### Elastic deformation of clearance free linear ball bearing in the contact zone

For a linear ball bearing LBCD 20, loaded with  $F_{\text{comb}} = 100 \text{ N}$  **diagram 1** provides an elastic deformation

$$\delta = 2 \mu\text{m} \text{ with } F_{\text{comb}} / C_0 = 100 / 5\,500 = 0,018$$

Furthermore, the impact of the operating clearance has to be added.

### Deflection of shaft and stiffness of the system

The bending at the points of application of load due to the shaft's own weight and an externally applied load  $F_z = 100 \text{ N}$  per bearing for a clamped shaft is calculated by:

$$(35) \quad f_{\text{ges}} = f_{\text{EG}} + f_{\text{EL}} = \frac{2,49 \cdot 10^{-7} \cdot [a \cdot (l - a)]^2}{d^2} + \frac{0,0165 \cdot F \cdot a^3 \cdot \left(2 - 3 \cdot \frac{a}{l}\right)}{d^4}$$

$$(36) \quad f_{\text{E,ges}} = \frac{2,49 \cdot 10^{-7} \cdot [457,5 \cdot (1\,000 - 457,5)]^2}{20^2} + \frac{0,0165 \cdot 100 \cdot 457,5^3 \cdot \left(2 - 3 \cdot \frac{457,5}{1\,000}\right)}{20^4}$$

$$(37) \quad f_{\text{E,ges}} = 38 \mu\text{m} + 620 \mu\text{m} = 658 \mu\text{m}$$

Thus, for a system "shaft clamped at both ends" the total stiffness becomes:

$$(38) \quad K_{\text{E,ges}} = \frac{F}{f_{\text{E,ges}} + \delta} = \frac{400 \text{ N}}{658 \mu\text{m} + 2 \mu\text{m}} = 0,606 \frac{\text{N}}{\mu\text{m}}$$

## Verification of degree of clamping

It's recommended that the degree of clamping is verified by measuring the bending of the shafts in their middle <sup>1)</sup>.

The bending in the middle due to the shaft's own weight and an externally applied load

$F_z = 100$  N per bearing for a clamped shaft is calculated by:

$$(39) \quad f_{E,max,ges} = f_{max,EG} + f_{max,EL} = \frac{1,56 \cdot 10^{-8} \cdot l^4}{d^2} + \frac{0,00412 \cdot F \cdot a^2 \cdot (3 \cdot l - 4 \cdot a)}{d^4}$$

$$(40) \quad f_{E,max,ges} = \frac{1,56 \cdot 10^{-8} \cdot 1\,000^4}{20^2} + \frac{0,00412 \cdot 100 \cdot 457,5^2 \cdot (3 \cdot 1\,000 - 4 \cdot 457,5)}{20^4}$$

$$(41) \quad f_{E,max,ges} = 39 \mu\text{m} + 630 \mu\text{m} = 699 \mu\text{m}$$

<sup>1)</sup> In case of housings that completely surround the middle of the shaft like Tandem- or Quadro-units, please get access to the shaft by drilling a bore.

## Alternate calculation with formulae for freely supported shaft

In addition to previous example with shaft secured in shaft blocks, the next three paragraphs on this page show the calculation if both ends of the shaft are only freely supported. Using following formulae calculates the upper fictive limit of the shaft bending.

### Calculation of misalignment caused by bending of the shaft under load

The upper limit of misalignment by freely supported shaft:

$$(42) \quad \alpha_{ges} = \alpha_{FG} + \alpha_{FL} = \frac{8,57 \cdot 10^{-7} \cdot (l^3 + 4 \cdot a^3 - 6 \cdot a^2 \cdot l)}{d^2} + \frac{0,17 \cdot F \cdot a \cdot (l - 2 \cdot a)}{d^4}$$

$$(43) \quad \alpha_{ges} = \frac{8,57 \cdot 10^{-7} \cdot (1\,000^3 + 4 \cdot 457,5^3 - 6 \cdot 457,5^2 \cdot 1\,000)}{20^2} + \frac{0,17 \cdot 100 \cdot 457,5 \cdot (1\,000 - 2 \cdot 457,5)}{20^4}$$

$$(44) \quad \alpha_{ges} = 0,25' + 4,13' = 4,38 \text{ (minutes of arc)}$$

**NOTE:**  $\alpha_{ges}$  for freely supported shaft is more than twice the value determined for clamped shaft.

Even for a freely supported shaft, the misalignment under its own weight and the applied load is below the limit value of 5'. Below this limit, the factor for misalignment is  $f_m=1$ .

### Deflection of shaft and stiffness of the system if shaft is freely supported

The upper limit of bending in the points of application of load due to the shaft's own weight and an externally applied load  $F = 100 \text{ N}$  per bearing for a freely supported shaft:

$$(45) \quad f_{F,ges} = f_{FG} + f_{FL} = \frac{2,49 \cdot 10^{-7} \cdot a \cdot (l - a) \cdot (l^2 - a^2 + a \cdot l)}{d^2} + \frac{0,0165 \cdot F \cdot a^2 \cdot (3 \cdot l - 4 \cdot a)}{d^4}$$

$$(46) \quad f_{F,ges} = \frac{2,49 \cdot 10^{-7} \cdot 457,5 \cdot (1\,000 - 457,5) \cdot (1\,000^2 - 457,5^2 + 457,5 \cdot 1\,000)}{20^2} + \frac{0,0165 \cdot 100 \cdot 457,5^2 \cdot (3 \cdot 1\,000 - 4 \cdot 457,5)}{20^4}$$

$$(47) \quad f_{F,ges} = 192,9 \mu\text{m} + 2\,525,4 \mu\text{m} = 2\,718,3 \mu\text{m}$$

Thus, for a system "freely supported shaft", the total stiffness becomes:

$$(48) \quad k_{F,ges} = \frac{F}{f_{F,ges} + \delta} = \frac{400 \text{ N}}{2\,718 \mu\text{m} + 2 \mu\text{m}} = 0,147 \frac{\text{N}}{\mu\text{m}} = \text{lower limit of stiffness}$$

### Verification of degree of clamping if shaft is freely supported

If the degree of clamping should be verified, the calculated upper limit of bending the shafts in their middle can be compared with the measured bending of the shafts in their middle.<sup>1)</sup>

$$(49) \quad f_{F,max,ges} = f_{max,FG} + f_{max,FL} = \frac{7,78 \cdot 10^{-8} \cdot l^4}{d^2} + \frac{0,00412 \cdot F \cdot a \cdot (3 \cdot l^2 - 4 \cdot a^2)}{d^4}$$

$$(50) \quad f_{F,max,ges} = \frac{7,78 \cdot 10^{-8} \cdot 1\,000^4}{20^2} + \frac{0,00412 \cdot 100 \cdot 457,5 \cdot (3 \cdot 1\,000^2 - 4 \cdot 457,5^2)}{20^4}$$

$$(51) \quad f_{F,max,ges} = 195 \mu\text{m} + 2\,548 \mu\text{m} = 2\,743 \mu\text{m}$$

<sup>1)</sup> In case of housings that completely surround the middle of the shaft like Tandem- or Quadro-units, please get access to the shaft by drilling a bore.

## 2.3 Technical data of plain bearings

Plain bearings can be used in certain applications where the use of rolling element bearings is inappropriate because of extreme operating conditions. This is especially relevant in cases of heavy shock loads or vibrations. For such applications, plain bearings are preferable to linear ball bearings although a higher friction is to be expected.

Ewellix linear plain bearings have the same dimensions as the corresponding linear ball bearings LBB and LBC. As in the case of linear ball bearings, bearing units are also available in addition to the individual bearings.

### 2.3.1 Range of applications

Linear plain bearings are made of copolymer polyoxymethylene (POM) with a special polyethylene to provide smooth and stick-slip-free operation. This combination is particularly suitable for plain bearing applications and is characterised by its excellent resistance to wear. The maximum acceptable surface pressure is 14 N/mm<sup>2</sup>. Recommended operating temperatures for continuous operation are between -40 and +80 °C and for short periods they may reach 120 °C. It should however be noted that the mechanical stability of the synthetic material is temperature dependent and falls from a rating of 100 % at room temperature to around 30 % at 100 °C.

### 2.3.2 Basic technical principles

The suitability of linear plain bearings for a given application depends largely on friction, heat dissipation, sliding properties of the mating surfaces and the efficiency of lubrication. In contrast to linear ball bearings, general statements regarding the service life and performance in specific applications cannot be accurately made. This is due to basic tribological factors such as the surface micro-structure, the effects of roughness and potential non-homogenous properties of materials. Different to wear, no guideline values can be stipulated for mentioned criteria.

### 2.3.3 Service life

In practice, the service life of a linear plain bearing depends:

- on the surface pressure
- upon the positive or negative effect, in the mixed or dry frictional area, of the increase in matching of the surfaces
- on the bearing clearance, and/or
- on the increase in bearing friction determined
  - by the progressive wear of the sliding surfaces,
  - by plastic deformation, and
  - by fatigue of the materials at the sliding surface.

Further factors of influence are dirt, corrosion, high frequency loads or cycles and shock loads. Depending on the individual application and choice of sliding surfaces, a different degree of wear or increase in friction may be acceptable.

### 2.3.4 “pv” load/speed relation

An appropriate method to check suitability of a certain bearing size is using the pv-diagram. Value p is the specific bearing load and v stands for the mean sliding speed. It can be assumed that the life of a plain bearing will be adequate if the combination of calculated p and v provides results below the red line in **diagram 16**.

$$(52) \quad p = \frac{P}{2 \cdot F_w \cdot C_4}$$

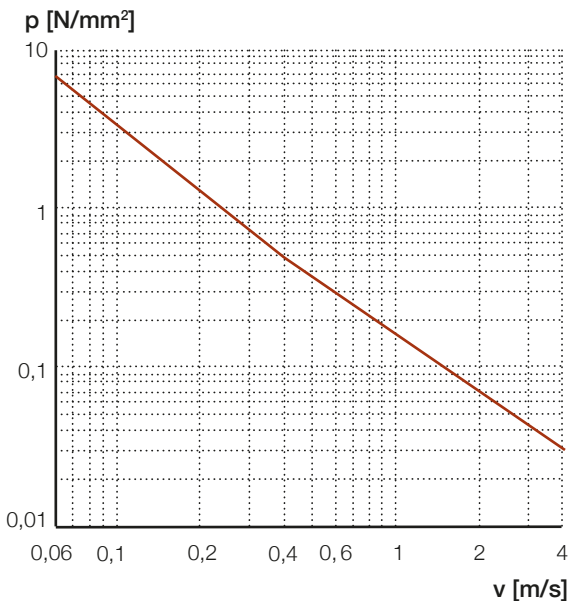
$$(53) \quad v = \frac{S_{sin} \cdot n}{30\,000}$$

where:

- $C_4$  = width of sliding surface (two per bearing), [mm]
- $F_w$  = nominal bore of linear plain bearing, [mm]
- $2 \cdot F_w \cdot C_4$  = load index (L→ **table 16** and **17**)
- $P$  = equivalent dynamic bearing load, [N]
- $n$  = stroke frequency, (number of movements from one end position to the other and back again), [ $\text{min}^{-1}$ ]
- $p$  = specific bearing load, [ $\text{N}/\text{mm}^2$ ]
- $S_{sin}$  = single stroke length, [mm]
- $v$  = mean sliding speed, [m/s]

Diagram 16

pv-diagram for linear plain bearings



### 2.3.5 Load ratings

The basic static load rating  $C_0$  is used when the linear plain bearing is loaded when stationary or occasionally slightly moved for adjustment. It should also be used where a dynamically loaded linear plain bearing is subjected to heavy shock loads. The basic static load rating  $C_0$  gives an indication of the load which can be accepted by a linear plain bearing without exceeding a prescribed degree of distortion of the sliding surface. It is assumed that components adjacent to the bearing are sufficiently rigid.

**IMPORTANT:** The screw connections must be examined for adequate safety. For overhead installations of linear guides, higher safety factors should be applied, see **chapter 2.2.1**.

**NOTE:** Load rating figures are always dependent on the basic definition and therefore the dynamic load ratings stated by different manufacturers are not necessarily comparable.

### 2.3.6 Friction

The frictional qualities of linear plain bearings depend primarily on the loading of the bearing, the sliding speed and the lubrication conditions. In addition, the surface qualities of the mating surface and the operating temperature are of importance. For linear plain bearings, the coefficient of friction for dry running conditions is between 0,17 and 0,21. The lowest figures for friction are generally obtained with high specific bearing loads and low sliding speeds. Under particularly unfavourable conditions and where the load is low, the indicated maximum values can be exceeded. The sliding material possesses the property of having a ‘stiction’ or static friction only slightly higher than the sliding friction coefficient and therefore stick-slip is avoided. Linear plain bearings equipped with additional external shaft seals show higher friction ratings.



## 2.3.7 Tolerances

In order to assure full interchangeability with linear ball bearings, the external dimensions and tolerances of linear plain bearings are identical to those of their ball bearing equivalents. They differ only in the degree of radial clearance which, in accordance with the recommendations for plain bearings, is significantly larger than for linear ball bearings.

The corresponding values can be obtained from **tables 16** and **17**.

During the running-in period of the linear plain bearing, a greater degree of wear will be observed which will lead to additional increase in radial clearance.

Table 16

*Radial clearance of LPBR bearings with shaft tolerance h7 / housing tolerance H7, and load index*

F <sub>w</sub> mm	Radial clearance		Load index $2 \cdot F_w \cdot C_4$ mm <sup>2</sup>
	max µm	min	
12	+175	+100	240
14	+195	+120	336
16	+205	+130	384
20	+210	+135	520
25	+210	+135	850
30	+260	+185	1 200
40	+330	+225	1 920
50	+380	+275	2 700

Table 17

*Radial clearance of LPAR and LPAT bearings with shaft tolerance h7 / housing tolerance H7, and load index*

F <sub>w</sub> mm	Radial clearance				Load index $2 \cdot F_w \cdot C_4$ mm <sup>2</sup>
	LPAR max µm	min	LPAT max	min	
5	+110	+55	–	–	80
8	+110	+55	–	–	144
12	+160	+110	+205	+130	264
16	+160	+110	+205	+130	416
20	+165	+110	+210	+135	680
25	+165	+110	+210	+135	1 100
30	+165	+110	+210	+135	1 500
40	+165	+110	+215	+140	2 160
50	+165	+110	+215	+140	3 200
60	+220	+160	+275	+190	4 800
80	+220	+160	+275	+190	8 320

## 2.3.8 Lubrication

Linear plain bearings may be used with or without lubrication. For protection against corrosion and for improvement of sealing, it is advisable in many applications to fill the bearing with lubricating grease. The most suitable greases are the corrosion resistant and water repellent lithium soap types of normal consistency, for instance SKF LGMT 3. Never use greases containing molybdenum disulphide or other solid lubricants. The grease quantity and relubrication interval depends on the application.

## 2.3.9 Shafts for plain bearings

Usually shafts for plain bearings are made of soft carbon steels with a ground surface. The surface roughness  $R_a$  should lie in the region of  $0,4 \mu\text{m}$ . Where the demands on the bearing are more stringent, hardened sliding surfaces with a surface hardness of at least 50 HRC or a coating of the surface for instance with hard chrome, can be advantageous. In such cases the value of  $R_a$  should be in the region of  $0,3 \mu\text{m}$ . A higher quality of the surface will also enhance the running qualities where a lower quality will result in increased wear.

## 2.3.10 Housing tolerances and mounting of plain bearings

Please read **chapter 4** where all design rules and further details are explained. For housing tolerances, see **chapter 4.1.2** and for plain bearing mounting, see **chapter 4.2.3**.

# 2.4 Legend

Legend		
$\alpha$	misalignment	[minutes of arc (°)]
$a$	distance between clamping and point of application of load	[mm]
$A$	starting point of movement in one direction	
$B$	next reversal point	
$\beta$	angle of direction of load	[°] = [degree]
$C$	dynamic load rating	[N]
$C_{max}$	maximal dynamic load rating depending of load direction	[N]
$C_{min}$	minimal dynamic load rating depending of load direction	[N]
$C_0$	basic static load rating	[N]
$C_{0,max}$	maximal static load rating depending of load direction	[N]
$C_{0,min}$	minimal static load rating depending of load direction	[N]
$c_1$	factor for reliability	
$c_2$	factor for operating conditions	
$\delta$	elastic deformation of clearance free ball bearing in contact zone	[ $\mu$ m]
$f$	shaft deflection	[ $\mu$ m]
$f_s$	factor for stroke length	[ $\mu$ m]
$f_{s,j}$	factor for stroke length for load phase j	
$f_i$	factor for number of loaded bearings per shaft	
$f_h$	factor for hardness of shaft	
$f_{h,0}$	static factor for hardness of shaft	
$f_l$	factor for direction of load	
$f_{l,j}$	factor for direction of load during a particular load phase	
$f_{l,0,j}$	static factor for direction of load during a load phase j	
$f_m$	factor for misalignment	
$f_{m,j}$	factor for misalignment during a load phase j	
$F_{ws,max}$	largest inscribed diameter measurements of the ball set	[ $\mu$ m]
$F_{ws,min}$	smallest inscribed diameter measurements of the ball set	[ $\mu$ m]
$F$	bearing load [N]	[N]
$F_{x,i}, F_{y,i}, F_{z,i}$	external loads in x-, y- and z-direction	[N]
$F_y, F_z$	bearing loads in y- and z-direction	[N]
$F_{y1}, F_{y2}, F_{y3}, F_{y4}, F_{z1}, F_{z2}, F_{z3}, F_{z4}$	bearing load in y- and z-direction at bearing No. 1, No. 2, No. 3 and No. 4	[N]
$F_{comb}$	combined bearing load	[N]
$F_{comb,j}$	combined bearing load during a load phase j	[N]
$K$	viscosity ratio	
$l$	shaft length	[mm]
$L_{nh}$	modified basic rating life	[h]
$L_{ns}$	modified basic rating life	[km]
$L_{10s}$	basic rating life	[km]
$M_{x1}, M_{x2}$	bearing torque load about x-axis at bearing No. 1, No. 2	[Nm]
$n$	stroke frequency	[double strokes/min]
$\nu$	actual kinematic viscosity	[mm <sup>2</sup> /s]
$\nu_1$	requisite minimum viscosity	[mm <sup>2</sup> /s]
$p$	life exponent of rolling elements	
$p$	specific bearing load for plain bearings	[N/mm <sup>2</sup> ]
$P$	equivalent dynamic load	[N]
$P_j$	equivalent dynamic load during a particular load phase	[N]
$P_m$	equivalent dynamic mean load	[N]
$P_{max}$	maximum equivalent load	[N]
$P_0$	maximum static load	[N]
$S_0$	static safety factor	
$S$	stroke length	[mm]
$S_j$	individual stroke length during a particular load phase	[mm]
$S_s$	sub stroke length	[mm]
$S_{sin}$	single stroke length	[mm]
$S_{tot}$	total stroke length	[mm]
$t$	temperature	[°C]
$v$	mean operating speed	[m/s]
$x, y, z$	lever arms of external loads	[mm]



**Dimensions from product data**

C	width of linear ball bearing	[mm]
C <sub>1</sub>	distance between outer faces of outer sleeve snap ring grooves	[mm]
C <sub>4</sub>	half of width of sliding surface of a plain bearing	[mm]
d	shaft diameter	[mm]
d <sub>1</sub>	inner diameter of hollow shaft	[mm]
F <sub>w</sub>	nominal inscribed diameter of the ball set = nominal diameter of bore of linear plain bearing	[mm]

**Indices**

i	counter for external loads
U	number of loads that act simultaneously
j	counter for load phases
V	number of load phases

3

Product range



## 3.1 Compact linear bearings

### Linear ball bearings – LBBR

The LBBR linear ball bearing is a unique Ewellix design. The compact bearing is excellent for integration of a linear guide function into other machine parts. It consists of a plastic cage with hardened steel raceway plates to guide the ball sets. The bearing dimensions are in line with ISO 10285 series 1. The LBBR raceway plates have been designed to fully utilize the entire length of the loaded zone to increase load ratings and extend bearing rating life. The plastic cage is designed to incorporate optimum functionality and performance. Well-designed ball recirculations offer nearly frictionless and low noise linear guiding function. Sealed variants with integral double lip seals keep the lubricant inside the bearing and provide optimum protection for contamination from outside. Sealed bearings in normal environments and applications are lubricated for life and nearly maintenance free. Bearings for almost frictionless guiding functions are fitted with non-contacting shields to protect the bearing from large particles. The cage itself provides self-holding functions of the bearings in an appropriate housing and under normal conditions. No additional axial fixation of the LBBR bearings is necessary. LBBR bearings are factory pre-lubricated with bearing grease. With suffix HV6, the linear bearings are available with stainless steel balls and raceway plates for corrosive or harsh environment applications.

### Linear plain bearings – LPBR

Ewellix linear plain bearings have the same dimensions as LBBR linear ball bearings. They are made of copolymer polyoxymethylene with a special polyethylene to provide smooth and stick-slip-free operation. Linear plain bearings are self-lubricating under normal conditions and are nearly maintenance free. They offer high static load ratings and are resistant to shock loads. Ewellix recommends a light coating of lubricant during installation to improve its performance during the running-in period. LPBR linear plain bearings are intended for high shock loads or shock load applications where motion speed is limited. The same as LBBR linear bearings, they are self-holding in an appropriate housing.

### External shaft seals - SP

Compact linear bearings in very harsh conditions can be equipped with additional external shaft seals to improve the service life of the bearing. SP seals have a steel insert covered by rubber material. Shaft seals are also self-holding inside an appropriate housing and require extra housing length to fit in. The high seal lip pressure on the shaft surface provides excellent functionality against contamination, when friction force is less important.



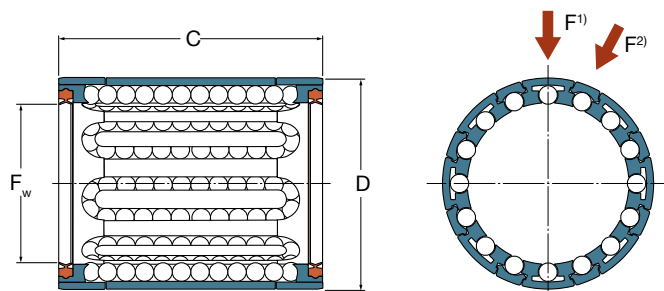
### 3.1.1 Compact linear ball bearings - LBBR

- Closed design

- Sizes from 3 mm to 50 mm
- Self-holding in appropriate housing <sup>3)</sup>
- Factory pre-lubricated with SKF LGEP 2 grease <sup>5)</sup>
- Lubricated for life under normal conditions
- Available in variants of 2 seals, 2 shields or seal and shield
- Available as bearing steel (standard) or stainless-steel variant
- Clearance or preload determined by shaft and housing bore tolerance



Pictured is LBBR 30-2LS



Picture shows LBBR with 2 double lip seals

Dimensions			No. of ball rows
$F_w$ mm	$D$ <sup>3)</sup>	C	–
3	7	10	4
4	8	12	4
5	10	15	4
6	12	22 <sup>4)</sup>	4
8	15	24	4
10	17	26	5
12	19	28	5
14	21	28	5
16	24	30	5
20	28	30	6
25	35	40	7
30	40	50	8
40	52	60	8
50	62	70	9

<sup>1)</sup> Direction for max. static load ratings of all sizes and max. dynamic load ratings of sizes 3 to 20 and 50

<sup>2)</sup> Direction for max. dynamic load ratings for size 25, 30, 40. For these 3 sizes, the directions of max. static and max. dynamic load ratings differ

<sup>3)</sup> The linear ball bearing requires no additional axial fixation when fitted into a bore with tolerance J7 or J6

<sup>4)</sup> Width 22 does not correspond to series 1 standards in ISO 10285

<sup>5)</sup> Can be re-lubricated in appropriate housings

## LBBR

Designations			Mass	Basic load ratings <sup>1)</sup>			
with shields	with 2 double lip seals	with 1 double lip seal		dynamic C	max	static C <sub>0</sub>	max
–			kg	min <sup>2)</sup>		min <sup>2)</sup>	
LBBR 3 <sup>3)</sup>	LBBR 3-2LS <sup>3)</sup>	LBBR 3-LS <sup>3) s)</sup>	0,0007	60	67	44	63
LBBR 4 <sup>3)</sup>	LBBR 4-2LS <sup>3)</sup>	LBBR 4-LS <sup>3) s)</sup>	0,001	75	85	60	85
LBBR 5 <sup>3)</sup>	LBBR 5-2LS <sup>3)</sup>	LBBR 5-LS <sup>3) s)</sup>	0,002	170	193	129	183
LBBR 6 A <sup>4)</sup>	LBBR 6 A-2LS <sup>4)</sup>	LBBR 6 A-LS <sup>4) s)</sup>	0,006	335	390	270	380
LBBR 8	LBBR 8-2LS	LBBR 8-LS <sup>s)</sup>	0,007	490	560	355	500
LBBR 10	LBBR 10-2LS	LBBR 10-LS <sup>s)</sup>	0,011	585	695	415	600
LBBR 12	LBBR 12-2LS	LBBR 12-LS <sup>s)</sup>	0,012	695	815	510	750
LBBR 14	LBBR 14-2LS	LBBR 14-LS <sup>s)</sup>	0,013	710	850	530	765
LBBR 16	LBBR 16-2LS	LBBR 16-LS <sup>s)</sup>	0,018	930	1 100	630	915
LBBR 20	LBBR 20-2LS	LBBR 20-LS <sup>s)</sup>	0,021	1 160	1 220	800	1 020
LBBR 25	LBBR 25-2LS	LBBR 25-LS <sup>s)</sup>	0,047	2 080	2 120	1 560	1 800
LBBR 30	LBBR 30-2LS	LBBR 30-LS <sup>s)</sup>	0,07	3 100	3 150	2 700	3 050
LBBR 40	LBBR 40-2LS	LBBR 40-LS <sup>s)</sup>	0,13	5 400	5 500	4 500	5 000
LBBR 50	LBBR 50-2LS	LBBR 50-LS <sup>s)</sup>	0,18	6 950	7 100	6 300	6 950

## LBBR in stainless steel

Designations			Mass	Basic load ratings <sup>1)</sup>			
with shields	with 2 double lip seals	with 1 double lip seal		dynamic C	max	static C <sub>0</sub>	max
–			kg	min <sup>2)</sup>		min <sup>2)</sup>	
LBBR 3/HV6 <sup>3)</sup>	LBBR 3-2LS/HV6 <sup>3)</sup>	LBBR 3-LS/HV6 <sup>3) n)</sup>	0,0007	60	67	44	63
LBBR 4/HV6 <sup>3)</sup>	LBBR 4-2LS/HV6 <sup>3)</sup>	LBBR 4-LS/HV6 <sup>3) n)</sup>	0,001	75	85	60	85
LBBR 5/HV6 <sup>3)</sup>	LBBR 5-2LS/HV6 <sup>3)</sup>	LBBR 5-LS/HV6 <sup>3) n)</sup>	0,002	170	193	129	183
LBBR 6 A/HV6 <sup>4)</sup>	LBBR 6 A-2LS/HV6 <sup>4)</sup>	LBBR 6 A-LS/HV6 <sup>4) n)</sup>	0,006	335	390	270	380
LBBR 8/HV6	LBBR 8-2LS/HV6	LBBR 8-LS/HV6 <sup>n)</sup>	0,007	490	560	355	500
LBBR 10/HV6	LBBR 10-2LS/HV6	LBBR 10-LS/HV6 <sup>n)</sup>	0,011	585	695	415	600
LBBR 12/HV6	LBBR 12-2LS/HV6	LBBR 12-LS/HV6 <sup>n)</sup>	0,012	695	815	510	750
LBBR 14/HV6	LBBR 14-2LS/HV6	LBBR 14-LS/HV6 <sup>n)</sup>	0,013	710	850	530	765
LBBR 16/HV6	LBBR 16-2LS/HV6	LBBR 16-LS/HV6 <sup>n)</sup>	0,018	930	1 100	630	915
LBBR 20/HV6	LBBR 20-2LS/HV6	LBBR 20-LS/HV6 <sup>n)</sup>	0,021	1 160	1 220	800	1020
LBBR 25/HV6	LBBR 25-2LS/HV6	LBBR 25-LS/HV6 <sup>n)</sup>	0,047	2 080	2 120	1 560	1 800
LBBR 30/HV6	LBBR 30-2LS/HV6	LBBR 30-LS/HV6 <sup>n)</sup>	0,07	3 100	3 150	2 700	3 050
LBBR 40/HV6	LBBR 40-2LS/HV6	LBBR 40-LS/HV6 <sup>n)</sup>	0,13	5 400	5 500	4 500	5 000
LBBR 50/HV6	LBBR 50-2LS/HV6	LBBR 50-LS/HV6 <sup>n)</sup>	0,18	6 950	7 100	6 300	6 950

Items without letter footnote are usually available from stock.

<sup>3)</sup> Delivery time on request

<sup>4)</sup> Delivery time usually 10 days for max. quantity of 4; larger quantities on request

<sup>1)</sup> Basic load ratings are valid for bearing steel and stainless steel variants, but they must be reduced if stainless steel shafts are used

<sup>2)</sup> To be used if mounted randomly and the direction of max. load rating and the main load are not aligned

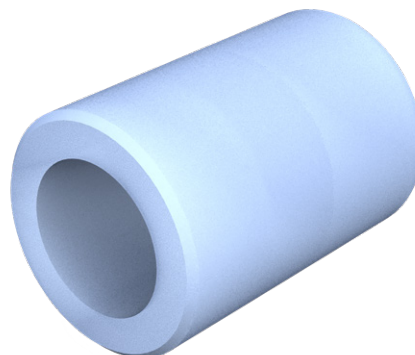
<sup>3)</sup> Delivered and packaged in units of 4 (always suffix -C004) preserved bearings which need lubrication before mounting

<sup>4)</sup> Factory pre-lubricated with lubricant Klueber Paraliq P460

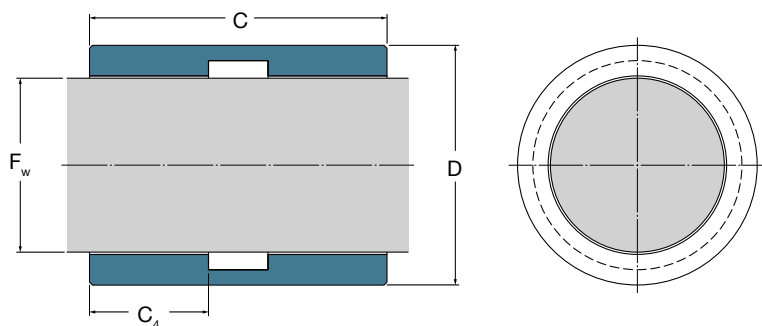
### 3.1.2 Compact linear plain bearings - LPBR

- Closed design

- Sizes from 12 mm to 50 mm
- Self-holding in appropriate housing <sup>1)</sup>
- Self-lubricating material
- Dimensionally interchangeable with LBBR linear bearings



*Pictured is LPBR 40*



Dimensions					Basic load ratings			Mass	Designations Linear plain bearings
$F_w$	$D^{1)}$ -0,1	$D_{housing}$	C	$C_4$	dyn. at 0,1 m/s	4 m/s	stat.		
mm					C		$C_0$	kg	
12	19,19	19	28	10	965	24	3 350	0,006	LPBR 12 <sup>3)</sup>
14	21,21	21	28	12	1 340	34	4 750	0,007	LPBR 14 <sup>3)</sup>
16	24,23	24	30	12	1 530	38	5 400	0,009	LPBR 16 <sup>3)</sup>
20	28,24	28	30	13	2 080	52	7 350	0,011	LPBR 20 <sup>3)</sup>
25	35,25	35	40	17	3 400	85	12 000	0,024	LPBR 25 <sup>3)</sup>
30	40,27	40	50	20	4 800	120	17 000	0,033	LPBR 30 <sup>3)</sup>
40	52,32	52	60	24	7 650	193	27 000	0,064	LPBR 40 <sup>3)</sup>
50	62,35	62	70	27	10 800	270	38 000	0,089	LPBR 50 <sup>3)</sup>

<sup>1)</sup>The linear plain bearing requires no additional axial fixation when fitted into a housing with bore diameter  $D_{housing}$  in tolerance J7 or J6

<sup>3)</sup>Delivery time usually 10 days for max. quantity of 4; larger quantities on request

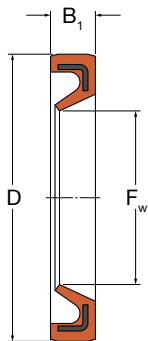
### 3.1.3 External shaft seals for compact bearings

- Sizes from 6 mm to 50 mm
- Self-holding in appropriate housing
- Request housings with longer length
- Excellent for high contamination environments

Find further details about sealing possibilities in **chapter 4.1.5**.



*Pictured is SP-30x40x04/SEAL*



Dimensions			Mass	Designations <sup>1)2)</sup>
F <sub>w</sub> mm	D	B <sub>1</sub>	Kg	–
6	12	2	0,0004	SP-06×12×02/SEAL
8	15	3	0,0007	SP-08×15×03/SEAL <sup>1)</sup>
10	17	3	0,0009	SP-10×17×03/SEAL
12	19	3	0,001	SP-12×19×03/SEAL
14	21	3	0,0011	SP-14×21×03/SEAL
16	24	3	0,0013	SP-16×24×03/SEAL
20	28	4	0,0021	SP-20×28×04/SEAL
25	35	4	0,0026	SP-25×35×04/SEAL
30	40	4	0,0036	SP-30×40×04/SEAL
40	52	5	0,0048	SP-40×52×05/SEAL
50	62	5	0,0105	SP-50×62×05/SEAL

Items without letter footnote are usually available from stock.

<sup>1)</sup> Delivery time on request

<sup>1)</sup> Max. speed 3 m/s

<sup>2)</sup> The designation of the shaft seal in catalogue and on the seal can differ. Eg. SP-10×17×3 (catalogue) and SP-10 17 3-4 (on the seal)

## 3.2 Compact linear units

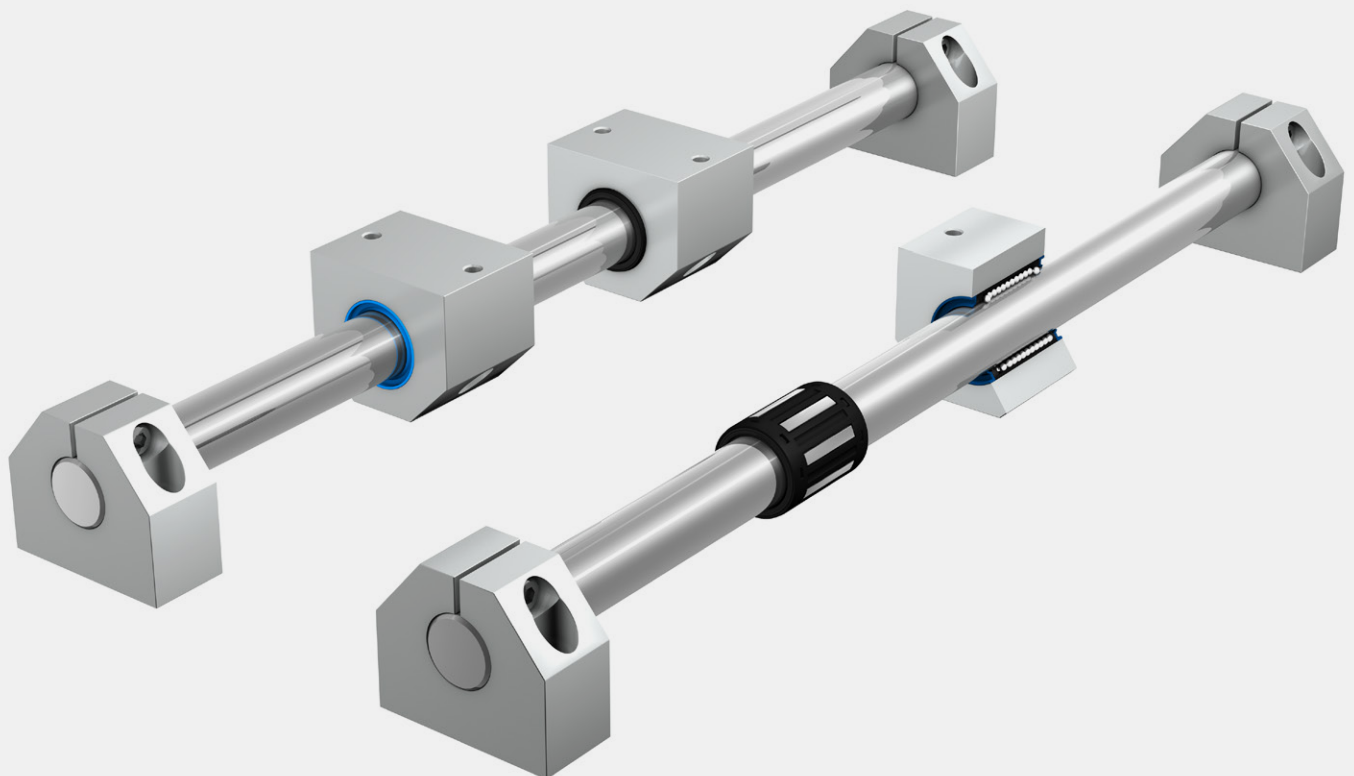
The combination of a linear bearing and housing is called a unit. The housing defines the clearance of the bearing and is essential for the linear function. Ewellix offers several types of linear bearing units to meet the demand for flexible slide design options with regard to width and length with modular standard products.

Linear bearing units of the compact range consist of a linear bearing and an aluminium housing. These units are extremely compact, cost-effective and lightweight. All linear bearing units are factory pre-lubricated for direct use. Thanks to factory pre-lubrication and the integral double lip seals, these units can operate without relubrication, under normal operating conditions. Therefore, the compact units have no grease fitting for relubrication.

If re-greasing is required by the application, please contact Ewellix for support.

For corrosive or humid environments, Ewellix offers different units with the stainless steel variant of the LBBR bearing. This is identified by a HV6 suffix in the designation, e.g. LUHR 20-2LS/HV6. Additionally, the units are available with plain bearings too.

To complete the linear guiding system, precision shafts and shaft blocks are needed. Please find suitable shaft blocks in **chapter 3.6** and precision shafts in different materials and designs in **chapter 3.7**.





**LUHR/LUJR**

LUHR and LUJR compact linear units are single units and consist of a closed aluminium housing and a LBBR linear ball bearing, with or without seals. LUJR are of the same design as LUHR but have an extended housing length for two additional external shaft seals for highly contaminated environments. LUHR and LUJR are also available with LPBR linear plain bearings. LUHR/LUJR units can be used to build any flexible design or configuration of compact linear slide systems. They can be bolted from the bottom and top side and are greased for life under normal conditions. Both designs are available for shaft diameters from 12 to 50 mm. Please find suitable shaft blocks in **chapter 3.6**.

**LTBR**

LTBR compact tandem units consist of two mounted LBBR linear ball bearings in an aluminium housing. The bearings of a tandem unit with designation -2LS have seals towards the outside of the housing. They are also available with LPBR linear plain bearings. LTBR units are particularly suitable for tables or slides of any width and can be bolted from the bottom and top side. They are greased for life under normal conditions. These units are available for shaft diameters ranging from 12 to 50 mm. Please find suitable shaft blocks in **chapter 3.6**.

**LTDR**

LTDR compact duo units are characterised by a defined shaft distance and contain two parallel LBBR linear ball bearings in an aluminium housing. The bearings can be with or without seals. They are also available with a LPBR linear plain bearing. LTDR units are suitable for slides of flexible length. The space between the two bearings of the duo configuration permits easy fitting of a linear drive. The units can be bolted from the bottom and top side and are greased for life under normal conditions. The units are available for shaft diameters from 12 to 50 mm. Please find suitable shaft blocks in **chapter 3.6**.

**LQBR**

LQBR compact quadro units contain four LBBR linear ball bearings within an aluminium housing. The bearings of a quadro unit with designation -2LS are sealed towards the outside of the housing. Quadro units can also be equipped with LPBR linear plain bearings. Such quadro units are perfectly suited to build slide systems and the space between the bearings permits easy fitting of a linear drive. Quadro linear bearing units are greased for life under normal conditions. The units can be bolted from the bottom and top side. Please find suitable shaft blocks in **chapter 3.6**.

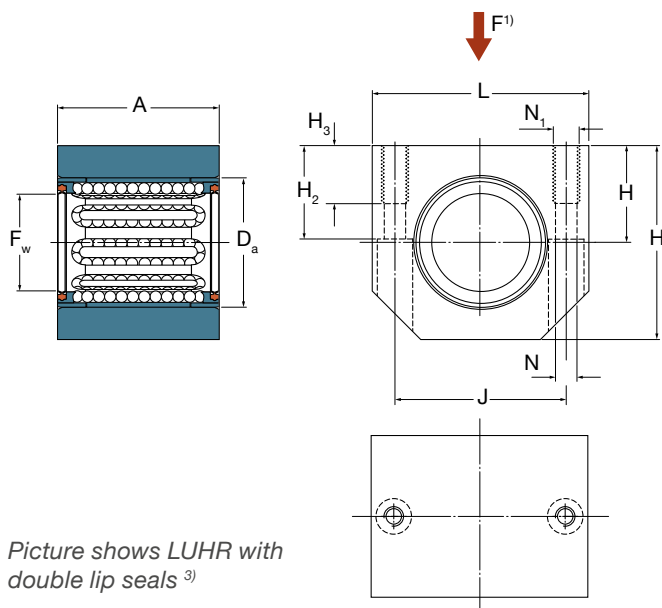
### 3.2.1 Compact linear units – LUHR

- LUHR with LBBR bearing
- LUHR PB with LPBR linear plain bearing

- Sizes from 12 mm to 50 mm, for flexible slide design
- Aluminium housing covers the entire bearing length
- Pre-lubricated units, greased for life under normal conditions
- Available as sealed or shielded variant for low friction
- Standard or stainless steel linear ball bearings are available
- Units can be bolted from the bottom and top side



Pictured is LUHR 20-2LS <sup>3)</sup>



Picture shows LUHR with double lip seals <sup>3)</sup>

Dimensions										
$F_w$	A	$D_a$	H $\pm 0,01$	$H_1$	$H_2$	$H_3$	L	J	$N^{2)}$	$N_1$
mm										-
12	28	19	17	33	16	11	40	29	4,3	M5
16	30	24	19	38	18	11	45	34	4,3	M5
20	30	28	23	45	22	13	53	40	5,3	M6
25	40	35	27	54	26	18	62	48	6,6	M8
30	50	40	30	60	29	18	67	53	6,6	M8
40	60	52	39	76	38	22	87	69	8,4	M10
50	70	62	47	92	46	26	103	82	10,5	M12

<sup>1)</sup> Direction for max. load ratings

<sup>2)</sup> For cylinder head screws with internal hexagon according to ISO 4762

<sup>3)</sup> Picture with shields or plain bearing differs

## LUHR

Designations				Mass kg	Basic load ratings <sup>1)</sup>			
LBBR bearing inside with shields		Stainless steel variant of LBBR bearing inside with double lip seals			dynamic C min		static C <sub>0</sub> min	
				max		max		
				N				
LUHR 12 <sup>s)</sup>	LUHR 12-2LS	LUHR 12/HV6 <sup>n)</sup>	LUHR 12-2LS/HV6 <sup>n)</sup>	0,08	695	815	510	750
LUHR 16 <sup>s)</sup>	LUHR 16-2LS	LUHR 16/HV6 <sup>n)</sup>	LUHR 16-2LS/HV6 <sup>n)</sup>	0,1	930	1 100	630	915
LUHR 20 <sup>s)</sup>	LUHR 20-2LS	LUHR 20/HV6 <sup>n)</sup>	LUHR 20-2LS/HV6 <sup>n)</sup>	0,14	1 160	1 220	800	1 020
LUHR 25 <sup>s)</sup>	LUHR 25-2LS	LUHR 25/HV6 <sup>n)</sup>	LUHR 25-2LS/HV6 <sup>n)</sup>	0,25	2 120	2 080	1 560	1 800
LUHR 30 <sup>s)</sup>	LUHR 30-2LS	LUHR 30/HV6 <sup>n)</sup>	LUHR 30-2LS/HV6 <sup>n)</sup>	0,37	3 150	3 100	2 700	3 050
LUHR 40 <sup>s)</sup>	LUHR 40-2LS	LUHR 40/HV6 <sup>n)</sup>	LUHR 40-2LS/HV6 <sup>n)</sup>	0,74	5 500	5 400	4 500	5 000
LUHR 50 <sup>s)</sup>	LUHR 50-2LS	LUHR 50/HV6 <sup>n)</sup>	LUHR 50-2LS/HV6 <sup>n)</sup>	1,19	6 950	7 100	6 300	6 950

## LUHR PB

Designations LPBR linear plain bearing inside	Mass kg	Basic load ratings		static <sup>2)</sup> C <sub>0</sub>
		dynamic C at 0,1 m/s N	at 4 m/s	
LUHR 12 PB <sup>s)</sup>	0,074	965	24	3 350
LUHR 16 PB <sup>s)</sup>	0,091	1 530	38	5 400
LUHR 20 PB <sup>s)</sup>	0,130	2 080	52	7 350
LUHR 25 PB <sup>s)</sup>	0,227	3 400	85	12 000
LUHR 30 PB <sup>s)</sup>	0,333	4 800	120	17 000
LUHR 40 PB <sup>s)</sup>	0,674	7 650	193	27 000
LUHR 50 PB <sup>s)</sup>	1,099	10 800	270	38 000

Items without letter footnote are usually available from stock.

<sup>s)</sup> Delivery time on request

<sup>n)</sup> Delivery time usually 10 days for max. quantity of 4; larger quantities on request

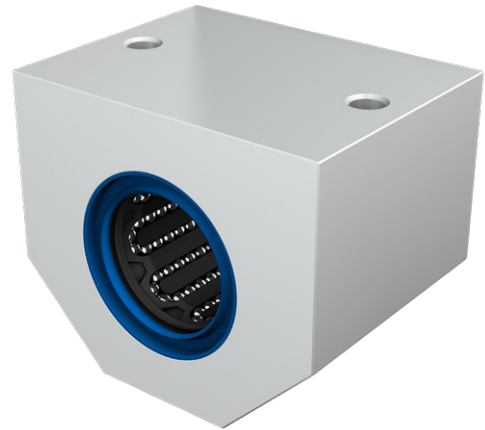
<sup>1)</sup> Basic load ratings are valid for bearing steel and stainless steel variants, but they must be reduced if stainless steel shafts are used

<sup>2)</sup> Valid if the loads onto the housing are exclusively in direction of red arrow, see dimensional drawing on left page

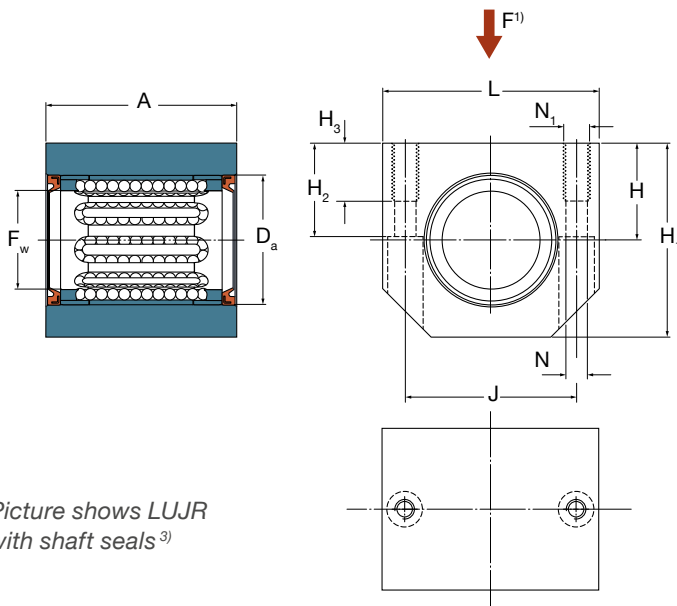
### 3.2.2 Compact linear units – LUJR

- LUJR with LBBR bearing and external shaft seals
- LUJR PB with LPBR linear plain bearing and external shaft seals

- Sizes from 12 mm to 50 mm, for flexible slide design
- Aluminium housing covers bearing and 2 shaft seals
- Pre-lubricated units, greased for life under normal conditions
- Equipped with two external seals for harsh environments
- Available as sealed (double sealed) or shielded variant
- Standard or stainless steel linear ball bearings are available
- Units can be bolted from the bottom and top side



Pictured is LUJR 20 <sup>3)</sup>



Picture shows LUJR with shaft seals <sup>3)</sup>

Dimensions										
$F_w$	A	$D_a$	H $\pm 0,01$	$H_1$	$H_2$	$H_3$	L	J	$N^2$	$N_1$
mm										-
12	35	19	17	33	16	11	40	29	4,3	M5
16	37	24	19	38	18	11	45	34	4,3	M5
20	39	28	23	45	22	13	53	40	5,3	M6
25	49	35	27	54	26	18	62	48	6,6	M8
30	59	40	30	60	29	18	67	53	6,6	M8
40	71	52	39	76	38	22	87	69	8,4	M10
50	81	62	47	92	46	26	103	82	10,5	M12

<sup>1)</sup> Direction for max. load ratings

<sup>2)</sup> For cylinder head screws with internal hexagon according to ISO 4762

<sup>3)</sup> Picture with double lip seals or plain bearing differs

## LUJR 2)

Designations				Mass kg	Basic load ratings <sup>1)</sup>			
with shields	with double lip seals	with shields	with double lip seals		dynamic C min N	max	static C <sub>0</sub> min	max
LBBR bearing inside plus shaft seals		Stainless steel variant of LBBR bearing inside plus shaft seals						
–								
LUJR 12	LUJR 12-2LS <sup>n)</sup>	LUJR 12/HV6 <sup>n)</sup>	LUJR 12-2LS/HV6 <sup>n)</sup>	0,10	695	815	510	750
LUJR 16	LUJR 16-2LS <sup>n)</sup>	LUJR 16/HV6 <sup>n)</sup>	LUJR 16-2LS/HV6 <sup>n)</sup>	0,12	930	1 100	630	915
LUJR 20	LUJR 20-2LS <sup>n)</sup>	LUJR 20/HV6 <sup>n)</sup>	LUJR 20-2LS/HV6 <sup>n)</sup>	0,18	1 160	1 220	800	1 020
LUJR 25	LUJR 25-2LS <sup>n)</sup>	LUJR 25/HV6 <sup>n)</sup>	LUJR 25-2LS/HV6 <sup>n)</sup>	0,30	2 120	2 080	1 560	1 800
LUJR 30	LUJR 30-2LS <sup>n)</sup>	LUJR 30/HV6 <sup>n)</sup>	LUJR 30-2LS/HV6 <sup>n)</sup>	0,44	3 150	3 100	2 700	3 050
LUJR 40	LUJR 40-2LS <sup>n)</sup>	LUJR 40/HV6 <sup>n)</sup>	LUJR 40-2LS/HV6 <sup>n)</sup>	0,86	5 500	5 400	4 500	5 000
LUJR 50	LUJR 50-2LS <sup>n)</sup>	LUJR 50/HV6 <sup>n)</sup>	LUJR 50-2LS/HV6 <sup>n)</sup>	1,37	6 950	7 100	6 300	6 950

## LUJR PB 2)

Designations	Mass kg	Basic load ratings		static <sup>3)</sup> C <sub>0</sub>
LPBR linear plain bearing inside plus shaft seals		dynamic C at 0,1 m/s N	at 4 m/s	
–				
LUJR 12 PB <sup>n)</sup>	0,09	965	24	3 350
LUJR 16 PB <sup>n)</sup>	0,11	1 530	38	5 400
LUJR 20 PB <sup>n)</sup>	0,17	2 080	52	7 350
LUJR 25 PB <sup>n)</sup>	0,28	3 400	85	12 000
LUJR 30 PB <sup>n)</sup>	0,40	4 800	120	17 000
LUJR 40 PB <sup>n)</sup>	0,79	7 650	193	27 000
LUJR 50 PB <sup>n)</sup>	1,28	10 800	270	38 000

Items without letter footnote are usually available from stock.

<sup>n)</sup> Delivery time on request

<sup>o)</sup> Delivery time usually 10 days for max. quantity of 4; larger quantities on request

<sup>1)</sup> Basic load ratings are valid for bearing steel and stainless steel variants, but they must be reduced if stainless steel shafts are used

<sup>2)</sup> Max. speed 3 m/s

<sup>3)</sup> Valid if the loads onto the housing are exclusively in direction of red arrow, see dimensional drawing on left page

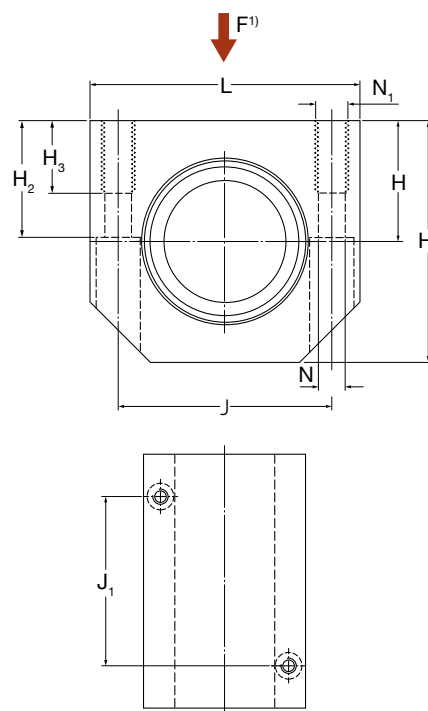
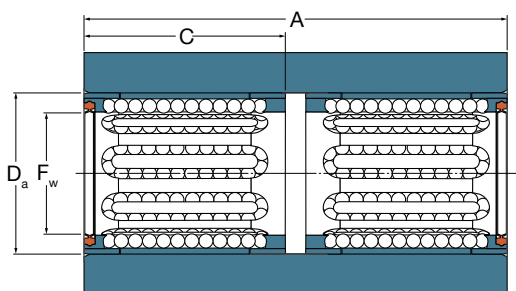
### 3.2.3 Compact tandem units - LTBR

- LTBR with LBBR bearings
- LTBR PB with LPBR linear plain bearings

- Sizes from 12 mm to 50 mm for flexible slide width
- Aluminium housing with 2 mounted bearings
- Pre-lubricated units, greased for life under normal conditions
- Available as sealed or shielded variant for low friction
- Standard or stainless steel linear ball bearings are available
- Units can be bolted from the bottom and top side



Pictured is LTBR 20-2LS <sup>3)</sup>



Picture shows LTBR with double lip seals on the outside <sup>3)</sup>

Dimensions												
F <sub>w</sub>	A	C	D <sub>a</sub>	H ±0,01	H <sub>1</sub>	H <sub>2</sub>	H <sub>3</sub>	J	J <sub>1</sub>	L	N <sup>2)</sup>	N <sub>1</sub>
mm												-
12	60	28	19	17	33	16	11	29	35	40	4,3	M5
16	65	30	24	19	38	18	11	34	40	45	4,3	M5
20	65	30	28	23	45	22	13	40	45	53	5,3	M6
25	85	40	35	27	54	26	18	48	55	62	6,6	M8
30	105	50	40	30	60	29	18	53	70	67	6,6	M8
40	125	60	52	39	76	38	22	69	85	87	8,4	M10
50	145	70	62	47	92	46	26	82	100	103	10,5	M12

<sup>1)</sup> Direction for max. load ratings

<sup>2)</sup> For 2 cylinder head screws with internal hexagon according to ISO 4762

<sup>3)</sup> Picture with shields or plain bearing differs

## LTBR

Designations			Mass kg	Basic load ratings <sup>1)</sup>			
LBRR bearing inside with shields	with double lip seals	Stainless steel variant of LBRR bearing inside with double lip seals		dynamic C		static C <sub>0</sub>	
–				min	max	min	max
LTBR 12 <sup>s)</sup>	LTBR 12-2LS <sup>s)</sup>	LTBR 12-2LS/HV6 <sup>n)</sup>	0,17	1 140	1 340	1 020	1 500
LTBR 16 <sup>s)</sup>	LTBR 16-2LS <sup>s)</sup>	LTBR 16-2LS/HV6 <sup>n)</sup>	0,22	1 530	1 800	1 270	1 830
LTBR 20 <sup>s)</sup>	LTBR 20-2LS <sup>s)</sup>	LTBR 20-2LS/HV6 <sup>n)</sup>	0,31	1 900	2 000	1 600	2 040
LTBR 25 <sup>s)</sup>	LTBR 25-2LS <sup>s)</sup>	LTBR 25-2LS/HV6 <sup>n)</sup>	0,54	3 450	3 400	3 150	3 600
LTBR 30 <sup>s)</sup>	LTBR 30-2LS <sup>s)</sup>	LTBR 30-2LS/HV6 <sup>n)</sup>	0,80	5 200	5 100	5 400	6 100
LTBR 40 <sup>s)</sup>	LTBR 40-2LS <sup>s)</sup>	LTBR 40-2LS/HV6 <sup>n)</sup>	1,57	9 000	8 800	9 000	10 000
LTBR 50 <sup>s)</sup>	LTBR 50-2LS <sup>s)</sup>	LTBR 50-2LS/HV6 <sup>n)</sup>	2,51	11 400	11 600	12 700	14 000

## LTBR PB

Designations LPBR linear plain bearing inside	Mass kg	Basic load ratings		static <sup>2)</sup> C <sub>0</sub>
		dynamic C at 0,1 m/s N	at 4 m/s	
–				
LTBR 12 PB <sup>n)</sup>	0,16	1 930	48	6 700
LTBR 16 PB <sup>n)</sup>	0,21	3 060	76	10 800
LTBR 20 PB <sup>n)</sup>	0,29	4 160	104	14 700
LTBR 25 PB <sup>n)</sup>	0,52	6 800	170	24 000
LTBR 30 PB <sup>n)</sup>	0,75	9 600	240	34 000
LTBR 40 PB <sup>n)</sup>	1,50	15 300	386	54 000
LTBR 50 PB <sup>n)</sup>	2,38	21 600	540	76 000

<sup>n)</sup> Delivery time on request

<sup>s)</sup> Delivery time usually 10 days for max. quantity of 4; larger quantities on request

<sup>1)</sup> Basic load ratings are valid for bearing steel and stainless steel variants, but they must be reduced if stainless steel shafts are used

<sup>2)</sup> Valid if the loads onto the housing are exclusively in direction of red arrow, see dimensional drawing on left page

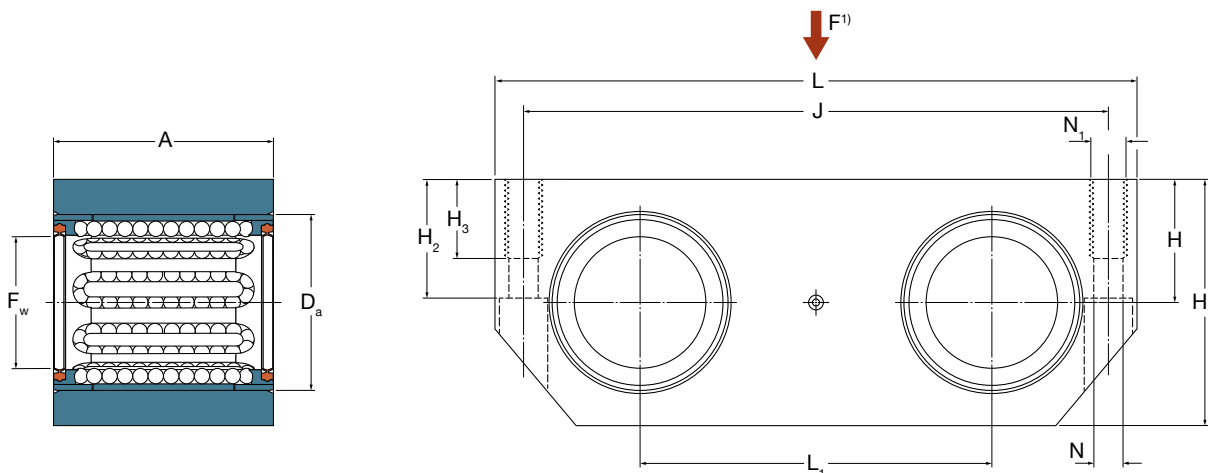
### 3.2.4 Compact duo units - LTDR

- LTDR with LBBR bearings
- LTDR PB with LPBR linear plain bearings

- Sizes from 12 mm to 50 mm, for flexible slide length
- Aluminium housing with 2 mounted bearings
- Pre-lubricated units, greased for life under normal conditions
- Available as sealed or shielded variant for low friction
- Standard or stainless steel linear ball bearings are available
- Units can be bolted from the bottom and top side



Pictured is LTDR 20-2LS <sup>3)</sup>



Picture shows LTDR with double lip seals <sup>3)</sup>

Dimensions											
F <sub>w</sub>	A	D <sub>a</sub>	H ±0,01	H <sub>1</sub>	H <sub>2</sub>	H <sub>3</sub>	J	L	L <sub>1</sub>	N <sup>2)</sup>	N <sub>1</sub>
mm											-
12	28	19	15	30	14	11	69	80	40	4,3	M5
16	30	24	17,5	35	16,5	11	86	96	52	4,3	M5
20	30	28	20	40	19	13	103	115	63	5,3	M6
25	40	35	25	50	24	18	123	136	75	6,6	M8
30	50	40	28	56	27	18	133	146	80	6,6	M8
40	60	52	35	70	34	22	166	184	97	8,4	M10
50	70	62	40	80	39	26	189	210	107	11	M12

<sup>1)</sup> Direction for max. load ratings

<sup>2)</sup> For 2 cylinder head screws with internal hexagon to ISO 4762 at the centre (0,5 A) of the linear bearing unit

<sup>3)</sup> Picture with shields or plain bearing differs



## LTDR

Designations			Mass kg	Basic load ratings <sup>1)</sup>			
LBBR bearing inside with shields	with double lip seals	Stainless steel variant of LBBR bearing inside with double lip seals		dynamic C		static C <sub>0</sub>	
–				min	max	min	max
LTDR 12 <sup>n)</sup>	LTDR 12-2LS <sup>s)</sup>	LTDR 12-2LS/HV6 <sup>n)</sup>	0,15	1 140	1 340	1 020	1 500
LTDR 16 <sup>n)</sup>	LTDR 16-2LS <sup>s)</sup>	LTDR 16-2LS/HV6 <sup>n)</sup>	0,22	1 530	1 800	1 270	1 830
LTDR 20 <sup>n)</sup>	LTDR 20-2LS <sup>s)</sup>	LTDR 20-2LS/HV6 <sup>n)</sup>	0,30	1 900	2 000	1 600	2 040
LTDR 25 <sup>n)</sup>	LTDR 25-2LS <sup>s)</sup>	LTDR 25-2LS/HV6 <sup>n)</sup>	0,58	3 450	3 400	3 150	3 600
LTDR 30 <sup>n)</sup>	LTDR 30-2LS <sup>s)</sup>	LTDR 30-2LS/HV6 <sup>n)</sup>	0,85	5 200	5 100	5 400	6 100
LTDR 40 <sup>n)</sup>	LTDR 40-2LS <sup>s)</sup>	LTDR 40-2LS/HV6 <sup>n)</sup>	1,56	9 000	8 800	9 000	10 000
LTDR 50 <sup>n)</sup>	LTDR 50-2LS <sup>s)</sup>	LTDR 50-2LS/HV6 <sup>n)</sup>	2,21	11 400	11 600	12 700	14 000

## LTDR PB

Designations LPBR linear plain bearing inside	Mass kg	Basic load ratings		static <sup>2)</sup> C <sub>0</sub>
		dynamic C at 0,1 m/s N	at 4 m/s	
–				
LTDR 12 PB <sup>n)</sup>	0,14	1 930	48	6 700
LTDR 16 PB <sup>n)</sup>	0,21	30 60	76	10 800
LTDR 20 PB <sup>n)</sup>	0,28	4 160	104	14 700
LTDR 25 PB <sup>n)</sup>	0,56	6 800	170	24 000
LTDR 30 PB <sup>n)</sup>	0,80	9 600	240	34 000
LTDR 40 PB <sup>n)</sup>	1,49	15 300	386	54 000
LTDR 50 PB <sup>n)</sup>	2,08	21 600	540	76 000

<sup>n)</sup> Delivery time on request

<sup>s)</sup> Delivery time usually 10 days for max. quantity of 4; larger quantities on request

<sup>1)</sup> Basic load ratings are valid for bearing steel and stainless steel variants, but they must be reduced if stainless steel shafts are used

<sup>2)</sup> Valid if the loads onto the housing are exclusively in direction of red arrow, see dimensional drawing on left page

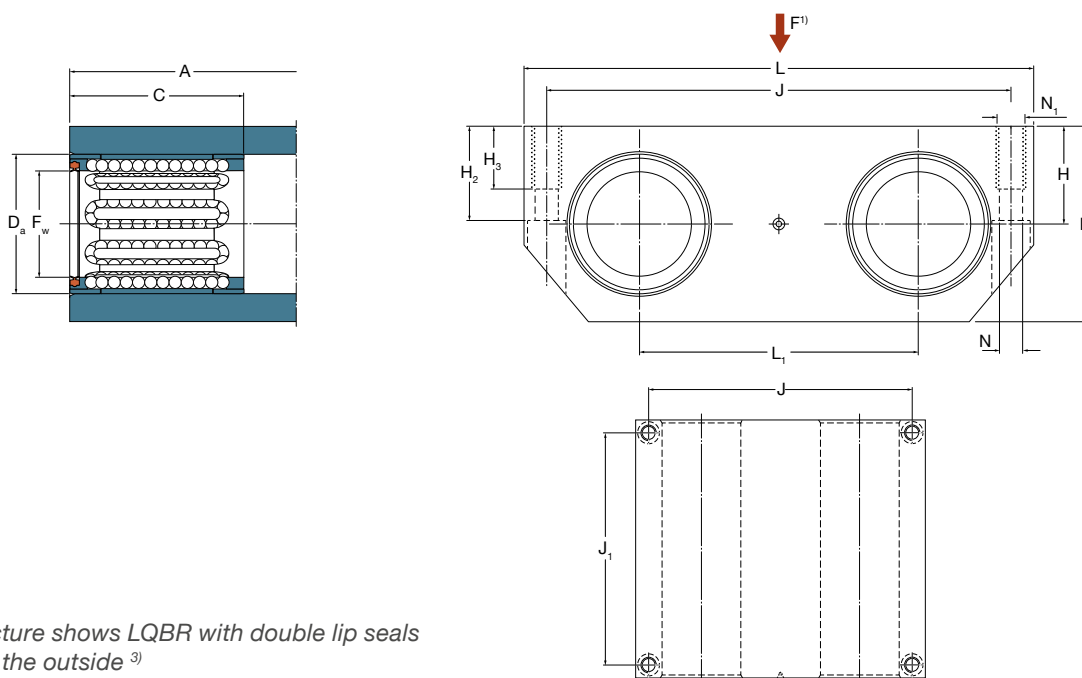
### 3.2.5 Compact quadro units - LQBR

- LQBR with LBBR bearings
- LQBR PB with LPBR linear plain bearings

- Sizes from 12 mm to 50 mm, a compact slide ready to use
- Aluminium housing with 4 mounted bearings
- Pre-lubricated units, greased for life under normal conditions
- Available as sealed or shielded variant for low friction
- Standard or stainless steel linear ball bearings are available
- Units can be bolted from the bottom and top side



Pictured is LQBR 20-2LS<sup>3)</sup>



Picture shows LQBR with double lip seals on the outside<sup>3)</sup>

Dimensions													
F <sub>w</sub>	A	C	D <sub>a</sub>	H ±0,01	H <sub>1</sub>	H <sub>2</sub>	H <sub>3</sub>	J	J <sub>1</sub>	L	L <sub>1</sub>	N <sup>2)</sup>	N <sub>1</sub>
mm													-
12	70	28	19	15	30	14	11	69	59	80	40	4,3	M5
16	80	30	24	17,5	35	16,5	11	86	70	96	52	4,3	M5
20	85	30	28	20	40	19	13	103	73	115	63	5,3	M6
25	100	40	35	25	50	24	18	123	87	136	75	6,6	M8
30	130	50	40	28	56	27	18	133	117	146	80	6,6	M8
40	150	60	52	35	70	34	22	166	132	184	97	8,4	M10
50	175	70	62	40	80	39	26	189	154	210	107	10,5	M12

<sup>1)</sup> Direction for max. load ratings

<sup>2)</sup> For 4 cylinder head screws with internal hexagon according to ISO 4762

<sup>3)</sup> Picture with shields or plain bearing differs

## LQBR

Designations			Mass kg	Basic load ratings <sup>1)</sup>			
LBBR bearing inside with shields	with double lip seals	Stainless steel variant of LBBR bearing inside with double lip seals		dynamic C		static C <sub>0</sub>	
–				min	max	min	max
LQBR 12 <sup>n)</sup>	LQBR 12-2LS <sup>s)</sup>	LQBR 12-2LS/HV6 <sup>n)</sup>	0,38	1 860	2 160	2 040	3 000
LQBR 16 <sup>n)</sup>	LQBR 16-2LS <sup>s)</sup>	LQBR 16-2LS/HV6 <sup>n)</sup>	0,57	2 500	2 900	2 550	3 650
LQBR 20 <sup>n)</sup>	LQBR 20-2LS <sup>s)</sup>	LQBR 20-2LS/HV6 <sup>n)</sup>	0,82	3 100	3 250	3 200	4 150
LQBR 25 <sup>n)</sup>	LQBR 25-2LS <sup>s)</sup>	LQBR 25-2LS/HV6 <sup>n)</sup>	1,43	5 600	5 500	6 300	7 200
LQBR 30 <sup>n)</sup>	LQBR 30-2LS <sup>s)</sup>	LQBR 30-2LS/HV6 <sup>n)</sup>	2,15	8 500	8 300	10 800	12 200
LQBR 40 <sup>n)</sup>	LQBR 40-2LS <sup>s)</sup>	LQBR 40-2LS/HV6 <sup>n)</sup>	3,83	14 600	14 300	18 000	20 000
LQBR 50 <sup>n)</sup>	LQBR 50-2LS <sup>s)</sup>	LQBR 50-2LS/HV6 <sup>n)</sup>	5,40	18 600	19 000	25 500	28 000

## LQBR PB

Designations LPBR linear plain bearing inside	Mass kg	Basic load ratings		static <sup>2)</sup> C <sub>0</sub>
		dynamic C at 0,1 m/s N	at 4 m/s	
–				
LQBR 12 PB <sup>n)</sup>	0,36	3 860	96	13 400
LQBR 16 PB <sup>n)</sup>	0,55	6 120	152	21 600
LQBR 20 PB <sup>n)</sup>	0,78	8 320	208	29 400
LQBR 25 PB <sup>n)</sup>	1,39	13 600	340	48 000
LQBR 30 PB <sup>n)</sup>	2,06	19 200	480	68 000
LQBR 40 PB <sup>n)</sup>	3,68	30 600	772	108 000
LQBR 50 PB <sup>n)</sup>	5,14	43 200	1 080	152 000

<sup>n)</sup> Delivery time on request<sup>s)</sup> Delivery time usually 10 days for max. quantity of 4; larger quantities on request<sup>1)</sup> Basic load ratings are valid for bearing steel and stainless steel variants, but they must be reduced if stainless steel shafts are used<sup>2)</sup> Valid if the loads onto the housing are exclusively in direction of red arrow, see dimensional drawing on left page

# 3.3 Standard linear ball bearings

## Linear ball bearings - LBC

Standard linear ball bearings type LBC are well established in the market and the best choice for a variety of applications. High load ratings combined with silent and smooth motion behaviour is provided by this high quality product. The range from diameter 5 mm to 80 mm is in line with ISO 10285 series 3 dimensions.

LBC bearings consist of a plastic cage with hardened steel raceway plates, balls and seals. The cage design and ball recirculation is optimised for low noise and nearly no maintenance. Our enormous experience in raceway technology is utilised for these linear ball bearings resulting in outstanding performance.

All Ewellix LBC bearings are available with double lip seals or with non-contacting shields. By using suffix -LS, the bearing is equipped with one shield and one seal on the right hand side of the bearing (→fig.1).

The linear bearings are factory pre-lubricated and the sizes from 12 mm to 80 mm have a lubrication port to regrease directly into the bearings. Ewellix grease fittings have double functionality and are used as axial as well as rotational fixation for the bearing inside the housing, which is mandatory. Please find additional information about fixation in **chapter 3.3.7** and **chapter 4.1.4**.

Different sizes come in different designs, to cover the whole range of LBC bearings. For each diameter from 5 mm to 80 mm, Ewellix offers the bearings either in the A-type (black) design or the D-type design (blue). Linear ball bearings of the D-design have a "D" after the size in the designation, e.g. LBCD 16D-2LS. For harsh environments, each LBC bearing is also available as a stainless steel variant identified by suffix /HV6 in the designation.

## Open type linear ball bearings - LBC

Ewellix offers closed bearings for unsupported shafts and open bearings for supported shafts. Supported shaft solutions are used for long linear travel distances where shaft bending of closed designs would be too high. LBC bearings from size 12 to 80 mm in open design are available with shields or seals and additionally are equipped with a longitudinal gap seal along the shaft sides. For longest life or demanding load applications, a heavy duty type bearing named LBHT is expanding the range. The LBHT bearing is equipped with the maximum number of raceway plates to reach the highest load rating per size.

## Self-aligning linear ball bearings - LBC

The open and closed types both are available with the self-aligning feature. Inaccurate machining of the mounting surfaces, misaligned shafts, or high load shaft bending can lead to internal stresses when the bearing system is bolted. For such applications, the use of a self-aligning linear ball bearing is recommended.

These bearings have a raceway plate with a special profile on the outside. A spherical elevation is ground in the centre of the raceway plate, which allows tilting of the whole bearing up to an angle of ±30 minutes of arc. Self-aligning bearings can significantly reduce stress and noise in many applications. The result is less peak loads and an extended bearing life at lower maintenance cost.

In order to ensure proper sealing functionality of the linear bearing, the outside diameter of the cage is reduced slightly. That allows the entire bearing including the seals to follow the tilting position exactly concentric around the shaft. Ewellix self-aligning bearings have proven to achieve good sealing and low friction performance in many applications. (→fig.2).

## Linear plain bearings - LPA

Ewellix linear plain bearings are interchangeable with LBC linear ball bearings in closed and open design. They are made from special polyoxymethylene plastic to provide smooth and stick-slip-free operation. Linear plain bearings are self-lubricating under normal conditions and are nearly maintenance free. They are used in high static load or shock load applications. Ewellix recommends a light lubrication during installation to improve the performance when running-in. LPA linear plain bearings must be fixed in appropriate housings.

Fig. 1

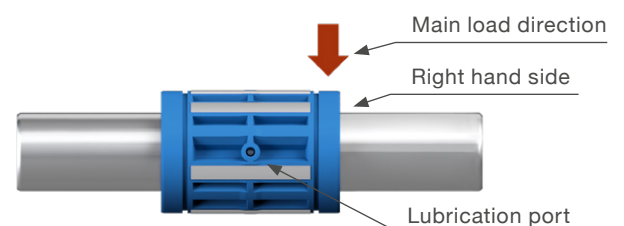
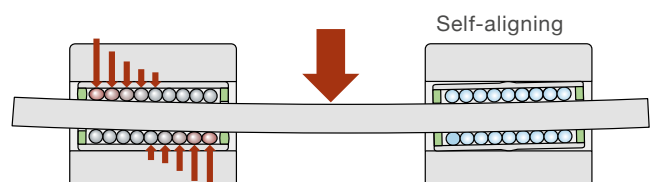


Fig. 2



**LBCR**

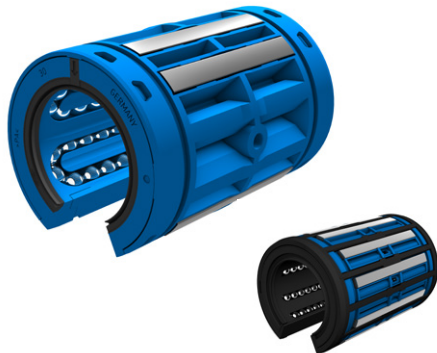
LBCR standard linear ball bearings with their optimised raceway length and the precisely shaped osculation are made for high loads. The straight design of the raceway plate is best for rigid linear bearing applications. The available variants and sizes from 5mm to 80 mm make it suitable for nearly every linear slide solution.

The operating clearance is determined by the housing and the shaft tolerance. When mounted into a slotted housing, the clearance can be adjusted to the needs of the machine. LBCR linear ball bearings must be fixed in an axial direction either via the Ewellix grease fittings or retaining rings according to DIN 471.

**LBCD - self-aligning**

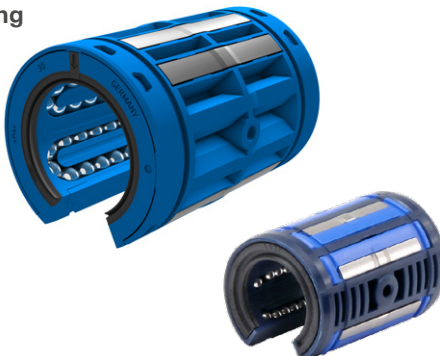
LBCD is the self-aligning type of the closed LBCR standard linear bearing. The self-aligning raceway plate allows bearing adjustments of maximum  $\pm 30$  minutes of arc. During a self-aligning process, the bearing seal always stays in optimum contact with the shaft. The LBCD is best for applications which require silent linear motion and smooth running performance. Ewellix offers them from size 12 mm to 50 mm.

Same as with LBCR bearings, the operating clearance is determined by the housing and the shaft tolerance while it can be adjusted in slotted housings towards the machine's needs. LBCD linear ball bearings must be fixed in axial direction either via the Ewellix grease fittings or retaining rings according to DIN 471.

**LBCT / LBHT**

LBCT and LBHT are open type standard linear ball bearings used for supported shaft solutions. They are best for long linear travel distance applications, where the shaft bending on closed types has its limitations. The straight raceway plates support solutions requiring high rigidity. The LBCT type is available from size 12 mm to 80 mm, where the heavy duty type LBHT is from size 20 mm to 50 mm. The LBHT linear ball bearing is equipped with the maximum number of raceway plates and is perfect for the highest loads. Both bearing types have a gap seal along the shaft side to avoid contamination.

In appropriate housings, like Ewellix housing LHCT, the clearance can be adjusted. Open type LBCT/LBHT linear ball bearings must be fixed to prevent axial and radial moves inside the housing.

**LBCF - self-aligning**

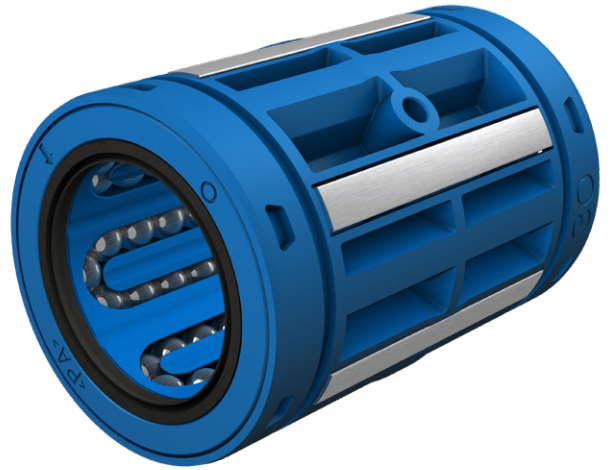
LBCF is the self-aligning variant of the open LBCT type. With the possible bearing adjustment of maximum  $\pm 30$  minutes of arc, it is best for silent linear motion and smooth running performance. With supported shafts, nearly unlimited stroke of linear slides is possible. The LBCF type is available from size 12 mm to 50 mm.

In appropriate housings, like Ewellix housing LHCT, the clearance can be adjusted. Open type LBCF linear ball bearings must be fixed to prevent axial and radial moves inside the housing. The fixation can be easily done with Ewellix grease fittings. For more information on grease fittings, see **chapter 3.3.7**.

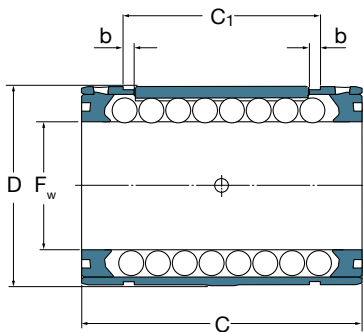
### 3.3.1 Standard linear ball bearings - LBCR

- Closed design

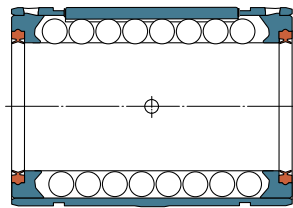
- Sizes from 5 mm to 80 mm
- Straight raceway design to support high loads
- Available in variants of 2 seals, 2 shields or seal and shield
- Available as bearing steel (standard) or stainless steel variant
- Factory pre-lubricated with SKF LGEP 2 grease, ready for use
- Clearance or preload determined by shaft and housing bore tolerance, in slotted housings adjustable
- Suitable grease fittings for axial fixation are in **chapter 3.3.7**



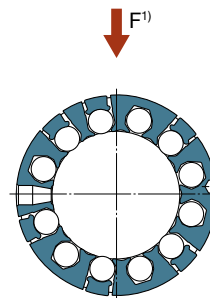
Pictured is LBCR 30 D-2LS <sup>2)</sup>



Picture shows LBCR D with shields <sup>2)</sup>



Picture shows LBCR D with 2 double lip seals <sup>2)</sup>



Dimensions					No. of ball rows
F <sub>w</sub>	D	C	C <sub>1</sub>	b min	
mm					–
5	12	22	14,2	1,1	4
8	16	25	16,2	1,1	4
12	22	32	22,6	1,3	5
16	26	36	24,6	1,3	5
20	32	45	31,2	1,6	6
25	40	58	43,7	1,85	6
30	47	68	51,7	1,85	6
40	62	80	60,3	2,15	6
50	75	100	78,5	2,65	7
60	90	125	102,1	3,15	7
80	120	165	133	4,15	7

<sup>1)</sup> Direction for max. load ratings

<sup>2)</sup> Picture of non D-series bearing differs

## LBCR

Designations			Mass	Basic load ratings <sup>1)</sup>			
with shields	with 2 double lip seals	with 1 double lip seal		dynamic C min <sup>2)</sup>	max	static C <sub>0</sub> min <sup>2)</sup>	max
–			kg	N			
LBCR 5 <sup>3) 4)</sup>	LBCR 5-2LS <sup>3) 4)</sup>	LBCR 5-LS <sup>3) 4) s)</sup>	0,005	280	320	210	300
LBCR 8 <sup>4)</sup>	LBCR 8-2LS <sup>4)</sup>	LBCR 8-LS <sup>4) s)</sup>	0,009	490	570	355	500
LBCR 12 D	LBCR 12 D-2LS	LBCR 12 D-LS <sup>s)</sup>	0,02	930	1 370	695	1 120
LBCR 16 D	LBCR 16 D-2LS	LBCR 16 D-LS <sup>s)</sup>	0,026	1 080	1 600	800	1 290
LBCR 20 D	LBCR 20 D-2LS	LBCR 20 D-LS <sup>s)</sup>	0,056	2 200	3 250	1 630	2 650
LBCR 25 D	LBCR 25 D-2LS	LBCR 25 D-LS <sup>s)</sup>	0,108	3 100	4 550	2 360	3 800
LBCR 30 D	LBCR 30 D-2LS	LBCR 30 D-LS <sup>s)</sup>	0,168	4 800	7 100	3 550	5 700
LBCR 40 D	LBCR 40 D-2LS	LBCR 40 D-LS <sup>s)</sup>	0,323	7 650	11 200	5 100	8 300
LBCR 50 A	LBCR 50 A-2LS	LBCR 50 A-LS <sup>s)</sup>	0,46	9 650	13 400	7 200	12 200
LBCR 60 A	LBCR 60 A-2LS	LBCR 60 A-LS <sup>s)</sup>	0,82	14 600	20 400	11 200	18 000
LBCR 80 A	LBCR 80 A-2LS	LBCR 80 A-LS <sup>s)</sup>	1,9	26 500	37 500	19 600	32 000

## LBCR in stainless steel

Designations			Mass	Basic load ratings <sup>1)</sup>			
with shields	with 2 double lip seals	with 1 double lip seal		dynamic C min <sup>2)</sup>	max	static C <sub>0</sub> min <sup>2)</sup>	max
–			kg	N			
LBCR 5/HV6 <sup>3) 4) n)</sup>	LBCR 5-2LS/HV6 <sup>3) 4) s)</sup>	LBCR 5-LS/HV6 <sup>3) 4) n)</sup>	0,005	280	320	210	300
LBCR 8/HV6 <sup>4) n)</sup>	LBCR 8-2LS/HV6 <sup>4) s)</sup>	LBCR 8-LS/HV6 <sup>4) n)</sup>	0,009	490	570	355	500
LBCR 12 D/HV6 <sup>n)</sup>	LBCR 12 D-2LS/HV6 <sup>s)</sup>	LBCR 12 D-LS/HV6 <sup>n)</sup>	0,02	930	1 370	695	1 120
LBCR 16 D/HV6 <sup>n)</sup>	LBCR 16 D-2LS/HV6 <sup>s)</sup>	LBCR 16 D-LS/HV6 <sup>n)</sup>	0,026	1 080	1 600	800	1 290
LBCR 20 D/HV6 <sup>n)</sup>	LBCR 20 D-2LS/HV6 <sup>s)</sup>	LBCR 20 D-LS/HV6 <sup>n)</sup>	0,056	2 200	3 250	1 630	2 650
LBCR 25 D/HV6 <sup>n)</sup>	LBCR 25 D-2LS/HV6 <sup>s)</sup>	LBCR 25 D-LS/HV6 <sup>n)</sup>	0,108	3 100	4 550	2 360	3 800
LBCR 30 D/HV6 <sup>n)</sup>	LBCR 30 D-2LS/HV6 <sup>s)</sup>	LBCR 30 D-LS/HV6 <sup>n)</sup>	0,168	4 800	7 100	3 550	5 700
LBCR 40 D/HV6 <sup>n)</sup>	LBCR 40 D-2LS/HV6 <sup>s)</sup>	LBCR 40 D-LS/HV6 <sup>n)</sup>	0,323	7 650	11 200	5 100	8 300
LBCR 50 A/HV6 <sup>n)</sup>	LBCR 50 A-2LS/HV6 <sup>s)</sup>	LBCR 50 A-LS/HV6 <sup>n)</sup>	0,46	9 650	13 400	7 200	12 200
LBCR 60 A/HV6 <sup>n)</sup>	LBCR 60 A-2LS/HV6 <sup>n)</sup>	LBCR 60 A-LS/HV6 <sup>n)</sup>	0,82	14 600	20 400	11 200	18 000
LBCR 80 A/HV6 <sup>n)</sup>	LBCR 80 A-2LS/HV6 <sup>n)</sup>	LBCR 80 A-LS/HV6 <sup>n)</sup>	1,9	26 500	37 500	19 600	32 000

Items without letter footnote are usually available from stock.

<sup>n)</sup> Delivery time on request

<sup>s)</sup> Delivery time usually 10 days for max. quantity of 4; larger quantities on request

<sup>1)</sup> Basic load ratings are valid for bearing steel and stainless steel variants, but they must be reduced if stainless steel shafts are used

<sup>2)</sup> To be used if mounted randomly and the direction of max. load rating and the main load are not aligned

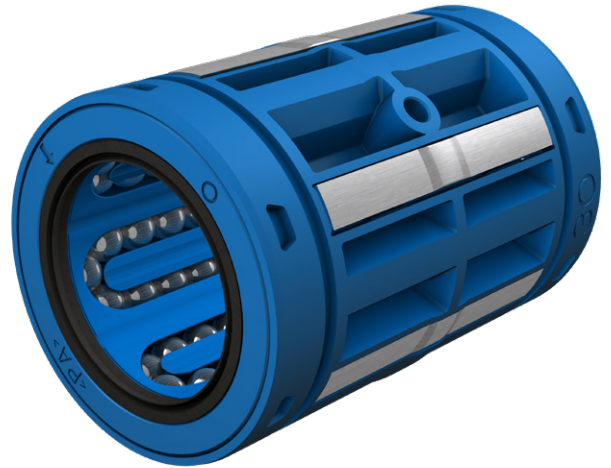
<sup>3)</sup> Factory pre-lubricated with lubricant Klueber Paraliq P460

<sup>4)</sup> Linear ball bearings LBCR 5 and LBCR 8 are without fixation hole

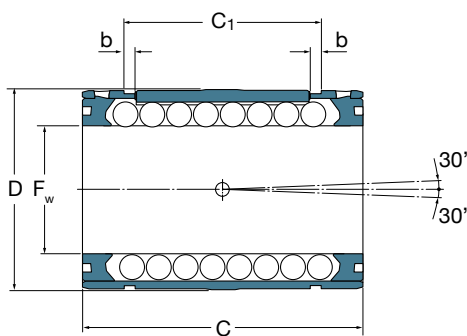
### 3.3.2 Standard linear ball bearings - LBCD

- Closed design, self-aligning

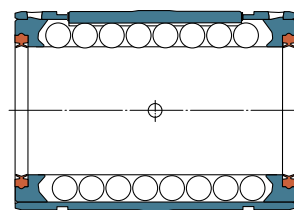
- Sizes from 12 mm to 50 mm
- Possible tilting angle of  $\pm 30$  minutes of arc (self-aligning)
- Available in variants of 2 seals, 2 shields or seal and shield
- Available as bearing steel (standard) or stainless steel variant
- Factory pre-lubricated with SKF LGEP 2 grease, ready for use
- Clearance or preload determined by shaft and housing bore tolerance, in slotted housings adjustable
- Suitable grease fittings for axial fixation are in **chapter 3.3.7**



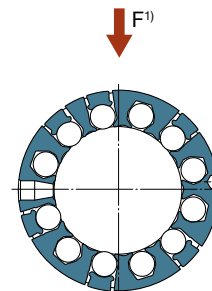
*Pictured is LBCD 30 D-2LS <sup>2)</sup>*



*Picture shows LBCD D with shields <sup>2)</sup>*



*Picture shows LBCD D with 2 double lip seals <sup>2)</sup>*



Dimensions						No. of ball rows
$F_w$	D	C	$C_1$	b min		
mm					–	
12	22	32	22,6	1,3	5	
16	26	36	24,6	1,3	5	
20	32	45	31,2	1,6	6	
25	40	58	43,7	1,85	6	
30	47	68	51,7	1,85	6	
40	62	80	60,3	2,15	6	
50	75	100	78,5	2,65	7	

<sup>1)</sup> Direction for max. load ratings

<sup>2)</sup> Picture of non D-series bearing differs



## LBCD

Designations			Mass	Basic load ratings <sup>1)</sup>			
with shields	with 2 double lip seals	with 1 double lip seal		dynamic C min <sup>2)</sup>	max	static C <sub>0</sub> min <sup>2)</sup>	max
–			kg	N			
LBCD 12 D	LBCD 12 D-2LS	LBCD 12 D-LS <sup>s)</sup>	0,02	800	1 220	570	930
LBCD 16 D	LBCD 16 D-2LS	LBCD 16 D-LS <sup>s)</sup>	0,025	950	1 400	655	1 060
LBCD 20 D	LBCD 20 D-2LS	LBCD 20 D-LS <sup>s)</sup>	0,055	1 730	2 550	1 120	1 800
LBCD 25 D	LBCD 25 D-2LS	LBCD 25 D-LS <sup>s)</sup>	0,106	2 600	3 800	1 430	2 320
LBCD 30 D	LBCD 30 D-2LS	LBCD 30 D-LS <sup>s)</sup>	0,166	3 800	5 600	2 320	3 750
LBCD 40 D	LBCD 40 D-2LS	LBCD 40 D-LS <sup>s)</sup>	0,316	6 550	9 650	3 350	5 700
LBCD 50 A	LBCD 50 A-2LS	LBCD 50 A-LS <sup>s)</sup>	0,44	8 000	11 200	4 150	6 950

## LBCD in stainless steel

Designations			Mass	Basic load ratings <sup>1)</sup>			
with shields	with 2 double lip seals	with 1 double lip seal		dynamic C min <sup>2)</sup>	max	static C <sub>0</sub> min <sup>2)</sup>	max
–			kg	N			
LBCD 12 D/HV6 <sup>n)</sup>	LBCD 12 D-2LS/HV6 <sup>s)</sup>	LBCD 12 D-LS/HV6 <sup>n)</sup>	0,02	800	1 220	570	930
LBCD 16 D/HV6 <sup>n)</sup>	LBCD 16 D-2LS/HV6 <sup>s)</sup>	LBCD 16 D-LS/HV6 <sup>n)</sup>	0,025	950	1 400	655	1 060
LBCD 20 D/HV6 <sup>n)</sup>	LBCD 20 D-2LS/HV6 <sup>s)</sup>	LBCD 20 D-LS/HV6 <sup>n)</sup>	0,055	1 730	2 550	1 120	1 800
LBCD 25 D/HV6 <sup>n)</sup>	LBCD 25 D-2LS/HV6 <sup>s)</sup>	LBCD 25 D-LS/HV6 <sup>n)</sup>	0,106	2 600	3 800	1 430	2 320
LBCD 30 D/HV6 <sup>n)</sup>	LBCD 30 D-2LS/HV6 <sup>s)</sup>	LBCD 30 D-LS/HV6 <sup>n)</sup>	0,166	3 800	5 600	2 320	3 750
LBCD 40 D/HV6 <sup>n)</sup>	LBCD 40 D-2LS/HV6 <sup>s)</sup>	LBCD 40 D-LS/HV6 <sup>n)</sup>	0,316	6 550	9 650	3 350	5 700
LBCD 50 A/HV6 <sup>n)</sup>	LBCD 50 A-2LS/HV6 <sup>s)</sup>	LBCD 50 A-LS/HV6 <sup>n)</sup>	0,44	8 000	11 200	4 150	6 950

Items without letter footnote are usually available from stock.

<sup>n)</sup> Delivery time on request

<sup>s)</sup> Delivery time usually 10 days for max. quantity of 4; larger quantities on request

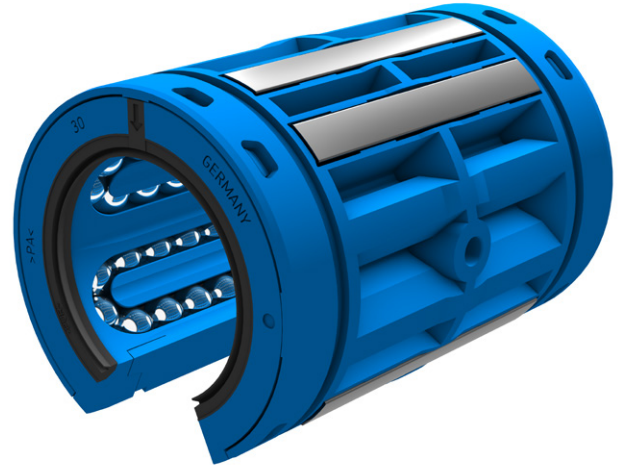
<sup>1)</sup> Basic load ratings are valid for bearing steel and stainless steel variants, but they must be reduced if stainless steel shafts are used

<sup>2)</sup> To be used if mounted randomly and the direction of max. load rating and the main load are not aligned

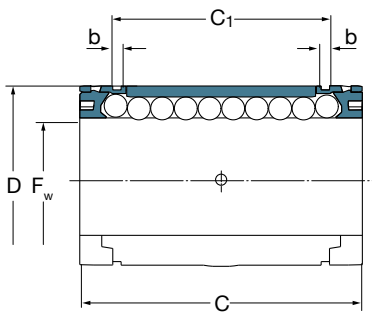
### 3.3.3 Standard linear ball bearings - LBCT

- Open design

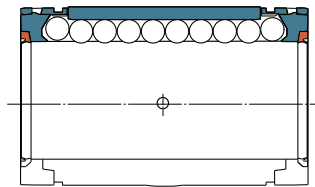
- Sizes from 12 mm to 80 mm
- Open design for long strokes together with supported shafts
- Straight raceway design to support high loads
- Available in variants of 2 seals, 2 shields or seal and shield
- Available as bearing steel (standard) or stainless steel variant
- Factory pre-lubricated with SKF LGEP 2 grease, ready for use
- Clearance or preload determined by shaft and housing bore tolerance, adjustable in Ewellix units
- Suitable grease fittings for axial fixation are in **chapter 3.3.7**



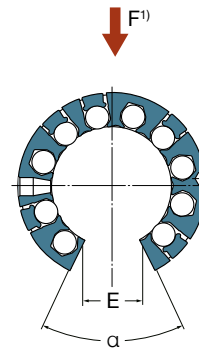
Pictured is LBCT 30 D-2LS <sup>2)</sup>



Picture shows LBCT D with shields <sup>2)</sup>



Picture shows LBCT D with 2 double lip seals <sup>2)</sup>



Dimensions							No. of ball rows
$F_w$	D	C	$C_1$	b min	$E^{3)}$	$\alpha$	
mm						Deg.	-
12	22	32	22,6	1,3	7,6	78	4
16	26	36	24,6	1,3	10,4	78	4
20	32	45	31,2	1,6	10,8	60	5
25	40	58	43,7	1,85	13,2	60	5
30	47	68	51,7	1,85	14,2	50	5
40	62	80	60,3	2,15	18,7	50	5
50	75	100	78,5	2,65	23,6	50	6
60	90	125	102,1	3,15	29,6	54	6
80	120	165	133	4,15	38,4	54	6

<sup>1)</sup> Direction for max. load ratings

<sup>2)</sup> Picture of non D-series bearing differs

<sup>3)</sup> Minimum sector width at diameter  $F_w$

## LBCT

Designations			Mass	Basic load ratings <sup>1)</sup>			
with shields	with 2 double lip seals	with 1 double lip seal		dynamic C	max	static C <sub>0</sub>	max
–			kg	min <sup>2)</sup>		min <sup>2)</sup>	
LBCT 12 D	LBCT 12 D-2LS	LBCT 12 D-LS <sup>s)</sup>	0,016	695	1 220	510	1 020
LBCT 16 D	LBCT 16 D-2LS	LBCT 16 D-LS <sup>s)</sup>	0,020	765	1 500	585	1 370
LBCT 20 D	LBCT 20 D-2LS	LBCT 20 D-LS <sup>s)</sup>	0,046	1 860	3 200	1 340	2 700
LBCT 25 D	LBCT 25 D-2LS	LBCT 25 D-LS <sup>s)</sup>	0,090	2 700	4 650	2 000	4 000
LBCT 30 D	LBCT 30 D-2LS	LBCT 30 D-LS <sup>s)</sup>	0,142	4 150	7 200	3 000	6 000
LBCT 40 D <sup>u)</sup>	LBCT 40 D-2LS <sup>u)</sup>	LBCT 40 D-LS <sup>u)</sup>	0,272	6 400	11 000	4 250	8 500
LBCT 50 A	LBCT 50 A-2LS	LBCT 50 A-LS <sup>s)</sup>	0,39	5 850	13 400	5 300	12 200
LBCT 60 A	LBCT 60 A-2LS	LBCT 60 A-LS <sup>s)</sup>	0,72	8 650	20 400	8 000	18 000
LBCT 80 A	LBCT 80 A-2LS	LBCT 80 A-LS <sup>s)</sup>	1,67	16 000	37 500	14 000	32 000

## LBCT in stainless steel

Designations			Mass	Basic load ratings <sup>1)</sup>			
with shields	with 2 double lip seals	with 1 double lip seal		dynamic C	max	static C <sub>0</sub>	max
–			kg	min <sup>2)</sup>		min <sup>2)</sup>	
LBCT 12 D/HV6 <sup>n)</sup>	LBCT 12 D-2LS/HV6 <sup>s)</sup>	LBCT 12 D-LS/HV6 <sup>n)</sup>	0,016	695	1 220	510	1 020
LBCT 16 D/HV6 <sup>n)</sup>	LBCT 16 D-2LS/HV6 <sup>s)</sup>	LBCT 16 D-LS/HV6 <sup>n)</sup>	0,020	765	1 500	585	1 370
LBCT 20 D/HV6 <sup>n)</sup>	LBCT 20 D-2LS/HV6 <sup>s)</sup>	LBCT 20 D-LS/HV6 <sup>n)</sup>	0,046	1 860	3 200	1 340	2 700
LBCT 25 D/HV6 <sup>n)</sup>	LBCT 25 D-2LS/HV6 <sup>s)</sup>	LBCT 25 D-LS/HV6 <sup>n)</sup>	0,090	2 700	4 650	2 000	4 000
LBCT 30 D/HV6 <sup>n)</sup>	LBCT 30 D-2LS/HV6 <sup>s)</sup>	LBCT 30 D-LS/HV6 <sup>n)</sup>	0,142	4 150	7 200	3 000	6 000
LBCT 40 D/HV6 <sup>u)</sup>	LBCT 40 D-2LS/HV6 <sup>u)</sup>	LBCT 40 D-LS/HV6 <sup>u)</sup>	0,272	6 400	11 000	4 250	8 500
LBCT 50 A/HV6 <sup>n)</sup>	LBCT 50 A-2LS/HV6 <sup>s)</sup>	LBCT 50 A-LS/HV6 <sup>n)</sup>	0,39	5 850	13 400	5 300	12 200
LBCT 60 A/HV6 <sup>n)</sup>	LBCT 60 A-2LS/HV6 <sup>s)</sup>	LBCT 60 A-LS/HV6 <sup>n)</sup>	0,72	8 650	20 400	8 000	18 000
LBCT 80 A/HV6 <sup>n)</sup>	LBCT 80 A-2LS/HV6 <sup>s)</sup>	LBCT 80 A-LS/HV6 <sup>n)</sup>	1,67	16 000	37 500	14 000	32 000

Items without letter footnote are usually available from stock.

<sup>n)</sup> Delivery time on request

<sup>s)</sup> Delivery time usually 10 days for max. quantity of 4; larger quantities on request

<sup>u)</sup> Size 40 under development; A-design linear ball bearing is available until replacement

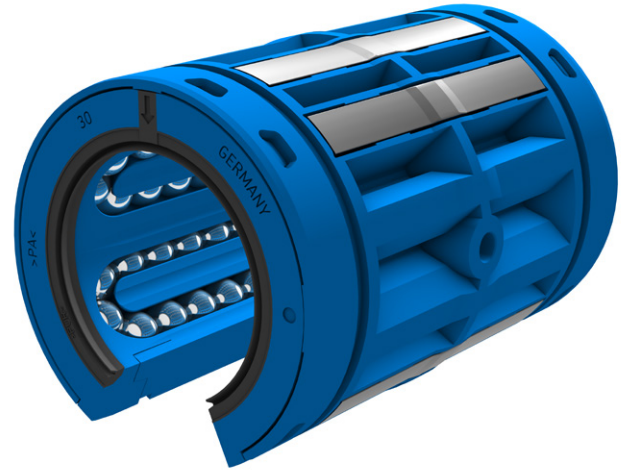
<sup>1)</sup> Basic load ratings are valid for bearing steel and stainless steel variants, but they must be reduced if stainless steel shafts are used

<sup>2)</sup> To be used if the direction of max. load rating and the main load are not aligned

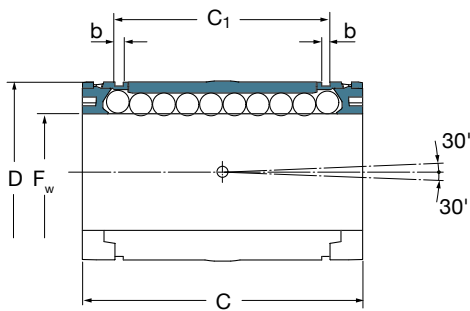
### 3.3.4 Standard linear ball bearings - LBCF

- Open design, self-aligning

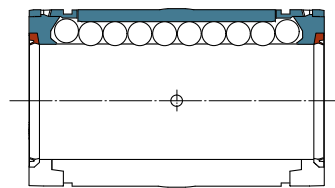
- Sizes from 12 mm to 50 mm
- Open design for long strokes together with supported shafts
- Possible tilting angle of  $\pm 30$  minutes of arc (self-aligning)
- Available in variants of 2 seals, 2 shields or seal and shield
- Available as bearing steel (standard) or stainless steel variant
- Factory pre-lubricated with SKF LGEP 2 grease, ready for use
- Clearance or preload determined by shaft and housing bore tolerance, adjustable in Ewellix units
- Suitable grease fittings for axial fixation are in **chapter 3.3.7**



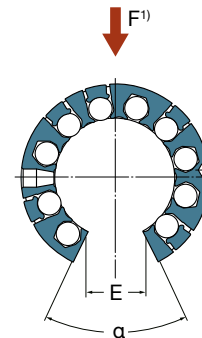
Pictured is LBCF 30 D-2LS <sup>2)</sup>



Picture shows LBCF D with shields <sup>2)</sup>



Picture shows LBCF D with 2 double lip seals <sup>2)</sup>



Dimensions							No. of ball rows
$F_w$	D	C	$C_1$	b min	$E^{3)}$	$\alpha$	
mm						Deg.	-
12	22	32	22,6	1,3	7,6	78	4
16	26	36	24,6	1,3	10,4	78	4
20	32	45	31,2	1,6	10,8	60	5
25	40	58	43,7	1,85	13,2	60	5
30	47	68	51,7	1,85	14,2	50	5
40	62	80	60,3	2,15	18,7	50	5
50	75	100	78,5	2,65	23,6	50	6

<sup>1)</sup> Direction for max. load ratings

<sup>2)</sup> Picture of non D-series bearing differs

<sup>3)</sup> Minimum sector width at diameter  $F_w$

## LBCF

Designations			Mass	Basic load ratings <sup>1)</sup>			
with shields	with 2 double lip seals	with 1 double lip seal		dynamic C	max	static C <sub>0</sub>	max
–			kg	min <sup>2)</sup>		min <sup>2)</sup>	
LBCF 12 D	LBCF 12 D-2LS	LBCF 12 D-LS <sup>n)</sup>	0,016	600	1 080	415	850
LBCF 16 D	LBCF 16 D-2LS	LBCF 16 D-LS <sup>n)</sup>	0,020	670	1 320	480	1 120
LBCF 20 D	LBCF 20 D-2LS	LBCF 20 D-LS <sup>n)</sup>	0,045	1 460	2 500	915	1 830
LBCF 25 D	LBCF 25 D-2LS	LBCF 25 D-LS <sup>n)</sup>	0,088	2 280	3 900	1 220	2 450
LBCF 30 D	LBCF 30 D-2LS	LBCF 30 D-LS <sup>n)</sup>	0,140	3 250	5 700	1 960	3 900
LBCF 40 D <sup>u)</sup>	LBCF 40 D-2LS <sup>u)</sup>	LBCF 40 D-LS <sup>u)</sup>	0,268	5 500	9 500	3 000	5 850
LBCF 50 A	LBCF 50 A-2LS	LBCF 50 A-LS <sup>n)</sup>	0,37	4 900	11 200	3 000	6 950

## LBCF in stainless steel

Designations			Mass	Basic load ratings <sup>1)</sup>			
with shields	with 2 double lip seals	with 1 double lip seal		dynamic C	max	static C <sub>0</sub>	max
–			kg	min <sup>2)</sup>		min <sup>2)</sup>	
LBCF 12 D/HV6 <sup>n)</sup>	LBCF 12 D-2LS/HV6 <sup>n)</sup>	LBCF 12 D-LS/HV6 <sup>n)</sup>	0,016	600	1080	415	850
LBCF 16 D/HV6 <sup>n)</sup>	LBCF 16 D-2LS/HV6 <sup>n)</sup>	LBCF 16 D-LS/HV6 <sup>n)</sup>	0,020	670	1 320	480	1 120
LBCF 20 D/HV6 <sup>n)</sup>	LBCF 20 D-2LS/HV6 <sup>n)</sup>	LBCF 20 D-LS/HV6 <sup>n)</sup>	0,045	1 460	2 500	915	1 830
LBCF 25 D/HV6 <sup>n)</sup>	LBCF 25 D-2LS/HV6 <sup>n)</sup>	LBCF 25 D-LS/HV6 <sup>n)</sup>	0,088	2 280	3 900	1 220	2 450
LBCF 30 D/HV6 <sup>n)</sup>	LBCF 30 D-2LS/HV6 <sup>n)</sup>	LBCF 30 D-LS/HV6 <sup>n)</sup>	0,140	3 250	5 700	1 960	3 900
LBCF 40 D/HV6 <sup>u)</sup>	LBCF 40 D-2LS/HV6 <sup>u)</sup>	LBCF 40 D-LS/HV6 <sup>u)</sup>	0,268	5 500	9 500	3 000	5 850
LBCF 50 A/HV6 <sup>n)</sup>	LBCF 50 A-2LS/HV6 <sup>n)</sup>	LBCF 50 A-LS/HV6 <sup>n)</sup>	0,37	4 900	11 200	3 000	6 950

Items without letter footnote are usually available from stock.

<sup>n)</sup> Delivery time on request

<sup>o)</sup> Delivery time usually 10 days for max. quantity of 4; larger quantities on request

<sup>u)</sup> Size 40 under development; A-design linear ball bearing is available until replacement

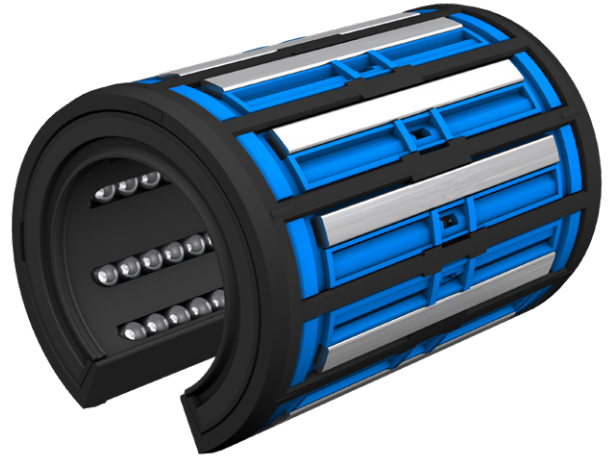
<sup>1)</sup> Basic load ratings are valid for bearing steel and stainless steel variants, but they must be reduced if stainless steel shafts are used

<sup>2)</sup> To be used if the direction of max. load rating and the main load are not aligned

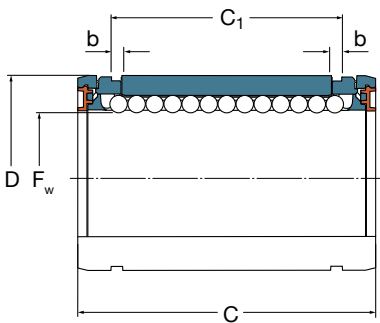
### 3.3.5 Standard linear ball bearings - LBHT

- Open design, heavy duty type

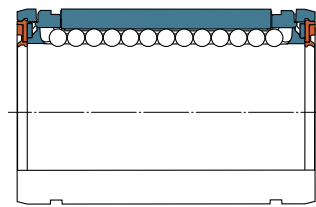
- Sizes from 20 mm to 50 mm
- Heavy duty type for maximum load ratings
- Open design for long strokes together with supported shafts
- Straight raceway design to support the high loads
- Available in variants of 2 seals, 2 shields or seal and shield
- Available as bearing steel (standard) or stainless-steel variant
- Factory pre-lubricated with SKF LGEP 2 grease, ready for use
- Relubrication via ring-groove in the housing, see LUCT BH unit
- Clearance or preload determined by shaft and housing bore tolerance, adjustable in Ewellix units



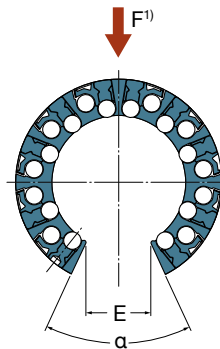
*Pictured is LBHT 30 A-2LS*



*Picture shows LBHT with shields*



*Picture shows LBHT with 2 double lip seals*



Dimensions							No. of ball rows
$F_w$	D	C	$C_1$	b min	$E^{2)}$	$\alpha$	
mm						Deg.	-
20	32	45	31,2	1,6	10,8	60	8
25	40	58	43,7	1,85	13,2	60	9
30	47	68	51,7	1,85	14,2	50	10
40	62	80	60,3	2,15	18,7	50	10
50	75	100	78,5	2,65	23,6	50	10

<sup>1)</sup> Direction for max. load ratings

<sup>2)</sup> Minimum sector width at diameter  $F_w$

## LBHT

Designations			Mass	Basic load ratings <sup>1)</sup>			
with shields	with 2 double lip seals	with 1 double lip seal		dynamic C	max	static C <sub>0</sub>	max
–			kg	min <sup>2)</sup>	N	min <sup>2)</sup>	
LBHT 20 A <sup>s)</sup>	LBHT 20 A-2LS	LBHT 20 A-LS <sup>n)</sup>	0,043	1 460	2 650	1 430	2 650
LBHT 25 A <sup>s)</sup>	LBHT 25 A-2LS	LBHT 25 A-LS <sup>n)</sup>	0,095	2 200	4 900	2 240	5 100
LBHT 30 A <sup>s)</sup>	LBHT 30 A-2LS	LBHT 30 A-LS <sup>n)</sup>	0,16	4 250	7 200	4 300	8 000
LBHT 40 A <sup>s)</sup>	LBHT 40 A-2LS	LBHT 40 A-LS <sup>n)</sup>	0,33	6 950	11 600	6 300	11 400
LBHT 50 A <sup>s)</sup>	LBHT 50 A-2LS	LBHT 50 A-LS <sup>n)</sup>	0,56	10 200	17 300	9 300	17 000

## LBHT in stainless steel

Designations			Mass	Basic load ratings <sup>1)</sup>			
with shields	with 2 double lip seals	with 1 double lip seal		dynamic C	max	static C <sub>0</sub>	max
–			kg	min <sup>2)</sup>	N	min <sup>2)</sup>	
LBHT 20 A/HV6 <sup>n)</sup>	LBHT 20 A-2LS/HV6 <sup>n)</sup>	LBHT 20 A-LS/HV6 <sup>n)</sup>	0,043	1 460	2 650	1 430	2 650
LBHT 25 A/HV6 <sup>n)</sup>	LBHT 25 A-2LS/HV6 <sup>n)</sup>	LBHT 25 A-LS/HV6 <sup>n)</sup>	0,095	2 200	4 900	2 240	5 100
LBHT 30 A/HV6 <sup>n)</sup>	LBHT 30 A-2LS/HV6 <sup>n)</sup>	LBHT 30 A-LS/HV6 <sup>n)</sup>	0,16	4 250	7 200	4 300	8 000
LBHT 40 A/HV6 <sup>n)</sup>	LBHT 40 A-2LS/HV6 <sup>n)</sup>	LBHT 40 A-LS/HV6 <sup>n)</sup>	0,33	6 950	11 600	6 300	11 400
LBHT 50 A/HV6 <sup>n)</sup>	LBHT 50 A-2LS/HV6 <sup>n)</sup>	LBHT 50 A-LS/HV6 <sup>n)</sup>	0,56	10 200	17 300	9 300	17 000

Items without letter footnote are usually available from stock.

<sup>n)</sup> Delivery time on request

<sup>s)</sup> Delivery time usually 10 days for max. quantity of 4; larger quantities on request

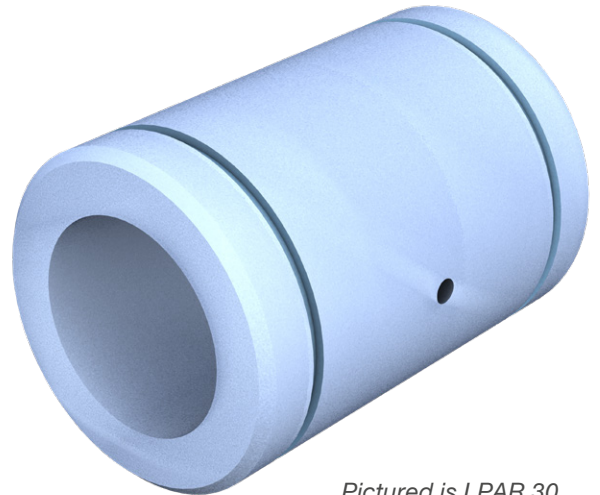
<sup>1)</sup> Basic load ratings are valid for bearing steel and stainless steel variants, but they must be reduced if stainless steel shafts are used

<sup>2)</sup> To be used if the direction of max. load rating and the main load are not aligned

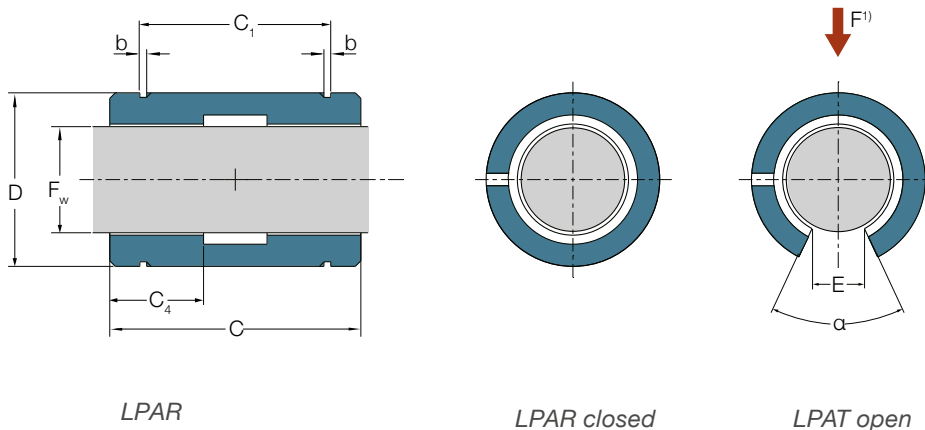
### 3.3.6 Standard linear plain bearings - LPAR/LPAT

- Closed and open design

- Sizes from 5 mm to 80 mm in closed design and from 12 mm to 80 mm in open design
- Dimensionally interchangeable with LBC linear bearings
- Self-lubricating material
- Equipped with lubrication hole
- Suitable grease fittings for axial fixation are in **chapter 3.3.7**



Pictured is LPAR 30



Dimensions							
$F_w$	D	C	$C_1$	b	$C_4$	$E^{2)}$	$\alpha$
mm	-0,1			min			Deg.
5	12	22	14,2	1,1	8	–	–
8	16	25	16,2	1,1	9	–	–
12	22	32	22,6	1,3	11	7,6	78
16	26	36	24,6	1,3	13	10,4	78
20	32	45	31,2	1,6	17	10,8	60
25	40	58	43,7	1,85	22	13,2	60
30	47	68	51,7	1,85	25	14,2	50
40	62	80	60,3	2,15	27	18,7	50
50	75	100	77,3	2,65	32	23,6	50
60	90	125	101,3	3,15	40	29,6	54
80	120	165	133,3	4,15	52	38,4	54

<sup>1)</sup> Direction for max. load ratings

<sup>2)</sup> Minimum sector width at diameter  $F_w$



## LPAR LPAT

Designations		Mass		Basic load ratings		
closed	open	closed	open	dynamic C at 0,1 m/s N	at 4 m/s	static C <sub>0</sub>
–		kg				
LPAR 5 <sup>s) 1)</sup>	–	0,003	–	320	8	1 120
LPAR 8 <sup>s) 1)</sup>	–	0,005	–	570	14	2 000
LPAR 12 <sup>s)</sup>	LPAT 12 <sup>s)</sup>	0,01	0,008	1 060	26	3 650
LPAR 16 <sup>s)</sup>	LPAT 16 <sup>s)</sup>	0,015	0,012	1 680	43	5 850
LPAR 20 <sup>s)</sup>	LPAT 20 <sup>s)</sup>	0,028	0,023	2 700	68	9 500
LPAR 25 <sup>s)</sup>	LPAT 25 <sup>s)</sup>	0,055	0,046	4 400	110	15 300
LPAR 30 <sup>s)</sup>	LPAT 30 <sup>s)</sup>	0,086	0,074	6 000	150	20 800
LPAR 40 <sup>s)</sup>	LPAT 40 <sup>s)</sup>	0,18	0,155	8 650	216	30 000
LPAR 50 <sup>s)</sup>	LPAT 50 <sup>s)</sup>	0,31	0,27	12 700	320	45 000
LPAR 60 <sup>s)</sup>	LPAT 60 <sup>s)</sup>	0,56	0,48	19 300	480	67 000
LPAR 80 <sup>s)</sup>	LPAT 80 <sup>s)</sup>	1,32	1,12	33 500	830	116 000

<sup>s)</sup> Delivery time on request

<sup>s)</sup> Delivery time usually 10 days for max. quantity of 4; larger quantities on request

<sup>1)</sup> Linear plain bearings LPAR 5 and LPAR 8 are without lubrication hole

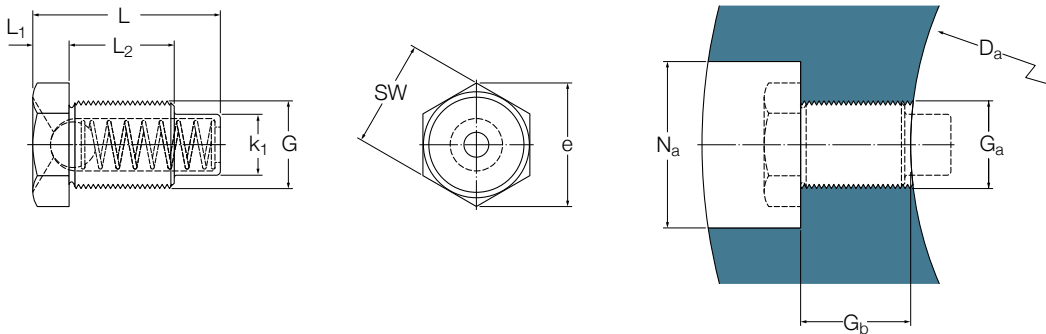
### 3.3.7 Grease fittings - VN-LHC

- For axial and radial fixation of LBC and LPA linear bearings inside units
- For easy and suitable bearing regreasing
- Funnel lubrication fitting according to DIN 3405
- For grease guns with pointed or pin-pointed nozzles



Please find appropriate grease fittings per bearing size in table below. For more details about axial and rotational fixation, please see **chapter 4.1.4**.

*Pictured is VN-LHC40*



Dimensions								Designations Grease fitting	Recommended attachment dimensions				
Bearing $F_w$	Grease fitting G	L	$L_1$	$L_2$	$k_1$	e	SW		Housings				Recommended tightening torque Nm
mm	-	mm						$D_a$	$G_a$	$G_b \pm 0,2$ mm	$N_a$ <sup>1)</sup>		
12	M4	7,7	1,5	3,5	3	5,5	5	VN-LHC 20	22	M4	3,8	13	1,0
16	M4	7,7	1,5	3,5	3	5,5	5	VN-LHC 20	26	M4	3,8	13	1,0
20	M4	7,7	1,5	3,5	3	5,5	5	VN-LHC 20	32	M4	3,8	13	1,0
25	M5	11,1	2	5	3,5	6,6	6	VN-LHC 40	40	M5	5,2	15	2,2
30	M5	11,1	2	5	3,5	6,6	6	VN-LHC 40	47	M5	5,2	15	2,2
40	M5	11,1	2	5	3,5	6,6	6	VN-LHC 40	62	M5	5,2	15	2,2
50	M6	14,8	2,5	7	4,5	7,8	7	VN-LHC 50	75	M6	7,2	15	3,7
60	M8	20,5	3,5	10,5	6	11,1	10	VN-LHC 80	90	M8	11,2	18	9,3
80	M8	20,5	3,5	10,5	6	11,1	10	VN-LHC 80	120	M8	5,2	18	9,3

Items are usually available from stock.

<sup>1)</sup>The bore diameter  $N_a$  of LUC and LUN housings in size 12,16 and 20 differs

## 3.4 Standard linear units

For flexible slide design, a comprehensive range of single linear bearing units is available. If flexible shaft distance and slide length is required, they are the best choice for the application. An easier slide setup can be reached with tandem units with two bearings and quadro units with four bearings. To support different mounting possibilities, a flanged unit is available as well. All units are factory pre-greased and ready for immediate use.

Ewellix offers units with die-cast housings LUC and housings LUN. All open and closed units except the flanged ones are made from aluminium. The high precision unit design is optimised to provide high strength and rigidity. The Ewellix LUC unit type is extremely lightweight and keeps acceleration and inertia forces at a minimum. For applications that require preload, slotted units are offered. Open type single bearing units have adjustable preload functionality.

Depending on the diameter, units in closed and open design are equipped with linear bearings from A- or D-design linear ball bearings. The housing design of open single units differs from A- to D-design. If the adjustable preload function of an open unit is used, an A-design bearing cannot be replaced by a D-design bearing.

For the utmost flexibility in design, the following variants can be chosen with all units: sealed or shielded, standard steel or stainless linear ball bearing, or plain bearing.

Each linear bearing unit is explained on the next pages with details about product data and designations.

For more information on shaft blocks or shaft supports, please see **chapter 3.6**.



**LUCR/LUCD**



Standard LUCR/LUCD linear units offer flexible design options to create economical linear slide systems. They are extremely lightweight and a perfect fit for low inertia and high acceleration. LUCR units from size 8 mm to 80 mm are equipped with rigid LBCR linear ball bearings or plain bearings, while LUCD units from size 12 mm to 50 mm are supplied with self-aligning LBCD linear ball bearings. All units are factory pre-greased and can be relubricated if necessary via the grease fitting. The grease fitting is also used for the fixation of the bearing in the housing. Exception is the size 8 mm unit, as it has bearings axially fixed with retaining rings.

**LUCS/LUCE**



Standard LUCS/LUCE linear units have a similar design as LUCR/LUCD units. They offer adjustable clearance or preload of the units via the slotted housing functionality. Please use the clearance adjustment carefully as it has an impact on service life. LUCS units from size 8 mm to 80 mm are equipped with rigid LBCR linear ball bearings or plain bearings, while LUCE units from size 12 mm to 50 mm are supplied with self-aligning LBCD linear ball bearings. All units are factory pre-greased and can be relubricated if necessary via the grease fitting. The grease fitting is also used for the fixation of the bearing in the housing. Exception is the size 8 mm unit as it has bearings axially fixed with retaining rings.

**LUCT/LUCF**

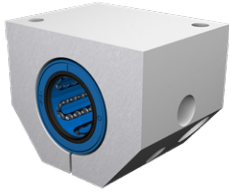


Standard LUCT/LUCF linear units have an open design and are made for applications with heavy loads and long travel distances. LUCT units from size 12 mm to 80 mm are equipped with rigid LBCT linear ball bearings or plain bearings, while LUCF units from size 12 mm to 50 mm are supplied with self-aligning LBCF linear ball bearings. All units are factory pre-greased and can be relubricated if necessary via the grease fitting. The grease fitting is also used for the fixation of the bearing in the housing. In addition, the clearance can be adjusted via the internal hexagon screw close to the opening of the housing.

**LUCT BH**



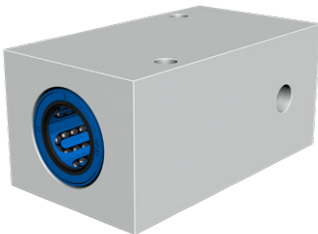
For maximum load rating, the open LUCT BH unit is equipped with the heavy duty type LBHT bearing. The LBHT bearing is equipped with the maximum number of raceway plates to reach the highest load ratings per size. These units from size 20 mm to 50 mm are factory pre-greased and can be relubricated if necessary using the grease fitting. The fixation of the bearing inside the housing is done by an internal hexagon screw.

**LUN**

Different to the die-cast LUC units, the standard linear bearing units LUN are made out of aluminium. The units can be bolted from both sides with appropriate screws. LUN units cover the linear bearing for its entire length by the housing. The LUN types are available in closed, slotted and open design. LUN units from 12 mm to 50 mm are equipped either with rigid linear ball bearings LBCR/LBCT, self-aligning bearings LBCD/LBCF or with plain bearings. They are factory pre-greased and can be relubricated if necessary via the grease fitting, which also keeps the bearing in axial and radial position. The slotted design offers adjustable clearance or preload of the units.

**LVCR/LVCD**

For flexible mounting purposes, the flanged linear bearing units are part of our range. The closed flange housing is made from cast iron. LVCR flanged units from size 12 mm to 80 mm are fitted with a rigid LBCR linear bearing or plain bearing, while LVCD flanged units from size 12 mm to 50 mm are equipped with self-aligning LBCD linear ball bearings. The bearings are axially located by a dowel pin. The flange is machined on both faces to enable mounting on the front or rear side in either direction. Flanged linear bearing units are factory pre-lubricated and are not made for relubrication.

**LTC**

Tandem linear units LTC consist of a solid aluminium housing with two linear ball bearings mounted one behind the other. Tandem linear units are a perfect fit for linear guiding systems of any required width. The units can be attached to a supporting surface from both sides using the appropriate screws and are available in closed and open design. The LTC units from size 12 mm to 50 mm are equipped either with rigid linear ball bearings LBCR/LBCT, self-aligning bearings LBCD/LBCF or with plain bearings. Tandem units are factory pre-greased and can be relubricated if necessary via the grease fitting, which also keeps the bearing in axial and radial position.

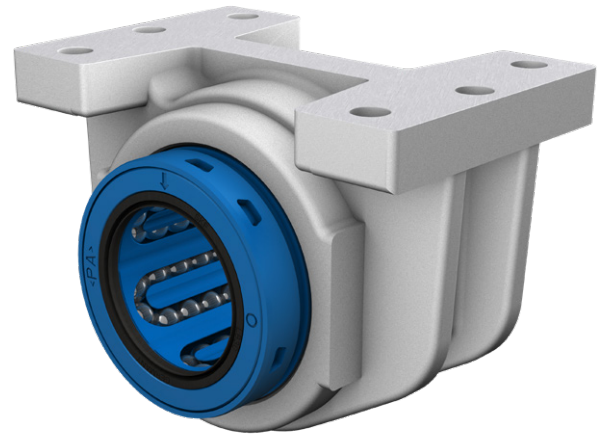
**LQC**

Quadro linear units LQC are linear slides ready to use with Ewellix shafts and shaft blocks. They consist of a one-piece aluminium housing with two parallel rows of two linear ball bearings. Quadro units can be attached to a supporting surface from both sides using the appropriate screws and are available in open and closed design. The LQC units from size 12 mm to 50 mm are equipped either with rigid linear ball bearings LBCR/LBCT, self-aligning bearings LBCD/LBCF or with plain bearings. Quadro units are factory pre-greased and can be relubricated if necessary via the grease fitting, which also keeps the bearing in axial and radial position. LQC in size 8 mm cannot be relubricated and can only be equipped with LBCR linear bearings and plain bearings.

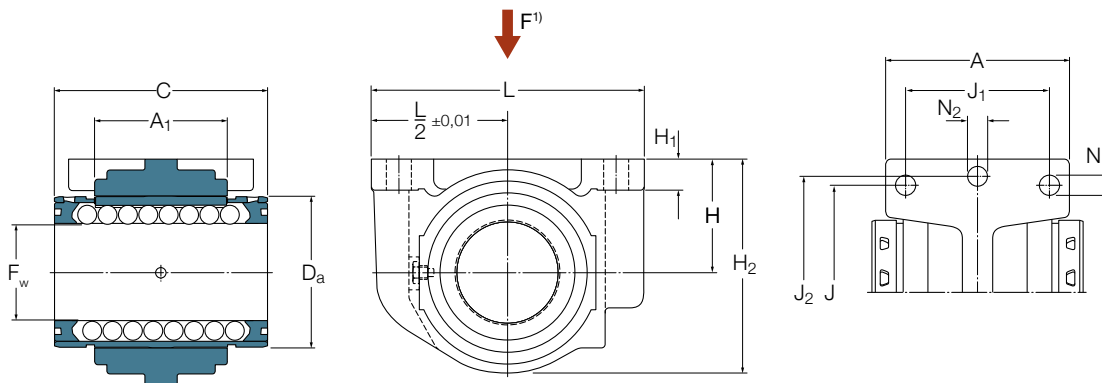
### 3.4.1 Standard linear units - LUCR/LUCD

- LUCR with rigid LBCR bearing
  - LUCD with self-aligning LBCD bearing
  - LUCR PA with LPAR linear plain bearing
- Closed design in sizes from 8 mm to 80 mm
  - Lightweight die-cast aluminium housing
  - Available in variants of 2 seals or 2 shields
  - Available as bearing steel (standard) or stainless steel variant
  - Factory pre-lubricated with SKF LGEP 2 grease, ready for use
  - Equipped with grease fitting
  - Able to bolt from top or bottom side

Please find suitable shaft blocks or shaft supports in **chapter3.6** and shafts in **chapter3.7**



*Pictured is LUCD 30 D-2LS 2)*



*Picture shows LUCD D with shields 2)*

Dimensions													
$F_w$	A	$A_1$	C	$D_a$	$H_{\pm 0,01}$	$H_1$	$H_2$	J	$J_1$	$J_2$	$L^{3)}$	$N^{4)}$	$N_2^{4)}$
mm													
8	27	14	25	16	15	5,5	28	25	20	35	45	3,2	5,3
12	31	20	32	22	18	6	34,5	32	23	42	52	4,3	5,3
16	34,5	22	36	26	22	7	40,5	40	26	46	56	4,3	5,3
20	41	28	45	32	25	8	48	45	32	58	70	4,3	6,4
25	52	40	58	40	30	10	58	60	40	68	80	5,3	6,4
30	59	48	68	47	35	10	67	68	45	76	88	6,4	6,4
40	74	56	80	62	45	12	85	86	58	94	108	8,4	8,4
50	66	72	100	75	50	14	99	108	50	116	135	8,4	10,5
60	84	95	125	90	60	18	118	132	65	138	160	10,5	13
80	113	125	165	120	80	22	158	170	90	180	205	13	13

<sup>1)</sup> Direction for max. load ratings  
<sup>2)</sup> Picture with non D-series bearing or plain bearing differs  
<sup>3)</sup> For units from size 50 to 80: Tolerance  $L/2 \pm 0,02$   
<sup>4)</sup> For cylinder head screws with internal hexagon according to ISO 4762

## LUCR

Designations				Mass kg	Basic load ratings <sup>1)</sup>			
LBCR bearing inside with shields		Stainless steel variant of LBCR bearing inside with 2 double lip seals			dynamic C		static C <sub>0</sub>	
-		-		min		max		
LUCR 8 <sup>2) s)</sup>	LUCR 8-2LS <sup>2) s)</sup>	LUCR 8/HV6 <sup>2) n)</sup>	LUCR 8 -2LS/HV6 <sup>n) 2)</sup>	0,027	490	570	355	500
LUCR 12 D <sup>s)</sup>	LUCR 12 D-2LS	LUCR 12 D/HV6 <sup>n)</sup>	LUCR 12 D-2LS/HV6 <sup>n)</sup>	0,058	930	1 370	695	1 120
LUCR 16 D <sup>s)</sup>	LUCR 16 D-2LS	LUCR 16 D/HV6 <sup>n)</sup>	LUCR 16 D-2LS/HV6 <sup>n)</sup>	0,076	1 080	1 600	800	1 290
LUCR 20 D <sup>s)</sup>	LUCR 20 D-2LS	LUCR 20 D/HV6 <sup>n)</sup>	LUCR 20 D-2LS/HV6 <sup>n)</sup>	0,157	2 200	3 250	1 630	2 650
LUCR 25 D <sup>s)</sup>	LUCR 25 D-2LS	LUCR 25 D/HV6 <sup>n)</sup>	LUCR 25 D-2LS/HV6 <sup>n)</sup>	0,308	3 100	4 550	2 360	3 800
LUCR 30 D <sup>s)</sup>	LUCR 30 D-2LS	LUCR 30 D/HV6 <sup>n)</sup>	LUCR 30 D-2LS/HV6 <sup>n)</sup>	0,450	4 800	7 100	3 550	5 700
LUCR 40 D <sup>s)</sup>	LUCR 40 D-2LS	LUCR 40 D/HV6 <sup>n)</sup>	LUCR 40 D-2LS/HV6 <sup>n)</sup>	0,799	7 650	11 200	5 100	8 300
LUCR 50 <sup>s)</sup>	LUCR 50-2LS	LUCR 50/HV6 <sup>n)</sup>	LUCR 50-2LS/HV6 <sup>n)</sup>	1,215	9 650	13 400	7 200	12 200
LUCR 60 <sup>s)</sup>	LUCR 60-2LS <sup>s)</sup>	LUCR 60/HV6 <sup>n)</sup>	LUCR 60-2LS/HV6 <sup>n)</sup>	2,160	14 600	20 400	11 200	18 000
LUCR 80 <sup>s)</sup>	LUCR 80-2LS <sup>s)</sup>	LUCR 80/HV6 <sup>n)</sup>	LUCR 80-2LS/HV6 <sup>n)</sup>	5,155	26 500	37 500	19 600	32 000

## LUCD

Designations				Mass kg	Basic load ratings <sup>1)</sup>			
Self-aligning LBCD bearing inside with shields		Stainless steel variant of self-aligning LBCD bearing inside with 2 double lip seals			dynamic C		static C <sub>0</sub>	
-		-		min		max		
LUCD 12 D <sup>s)</sup>	LUCD 12 D-2LS	LUCD 12 D/HV6 <sup>n)</sup>	LUCD 12 D-2LS/HV6 <sup>n)</sup>	0,058	800	1 220	570	930
LUCD 16 D <sup>s)</sup>	LUCD 16 D-2LS	LUCD 16 D/HV6 <sup>n)</sup>	LUCD 16 D-2LS/HV6 <sup>n)</sup>	0,075	950	1 400	655	1 060
LUCD 20 D <sup>s)</sup>	LUCD 20 D-2LS	LUCD 20 D/HV6 <sup>n)</sup>	LUCD 20 D-2LS/HV6 <sup>n)</sup>	0,156	1 730	2 550	1 120	1 800
LUCD 25 D <sup>s)</sup>	LUCD 25 D-2LS	LUCD 25 D/HV6 <sup>n)</sup>	LUCD 25 D-2LS/HV6 <sup>n)</sup>	0,306	2 600	3 800	1 430	2 320
LUCD 30 D <sup>s)</sup>	LUCD 30 D-2LS	LUCD 30 D/HV6 <sup>n)</sup>	LUCD 30 D-2LS/HV6 <sup>n)</sup>	0,448	3 800	5 600	2 320	3 750
LUCD 40 D <sup>s)</sup>	LUCD 40 D-2LS	LUCD 40 D/HV6 <sup>n)</sup>	LUCD 40 D-2LS/HV6 <sup>n)</sup>	0,792	6 550	9 650	3 350	5 700
LUCD 50 <sup>s)</sup>	LUCD 50-2LS	LUCD 50/HV6 <sup>n)</sup>	LUCD 50-2LS/HV6 <sup>n)</sup>	1,195	8 000	11 200	4 150	6 950

## LUCR PA

Designations	Mass kg	Basic load ratings		static <sup>3)</sup> C <sub>0</sub>
		dynamic C at 0,1 m/s	at 4 m/s	
LUCR 8 PA <sup>n) 2)</sup>	0,023	570	14	2 000
LUCR 12 PA <sup>n)</sup>	0,048	1 060	26	3 650
LUCR 16 PA <sup>n)</sup>	0,065	1 680	43	5 850
LUCR 20 PA <sup>n)</sup>	0,129	2 700	68	9 500
LUCR 25 PA <sup>n)</sup>	0,255	4 400	110	15 300
LUCR 30 PA <sup>n)</sup>	0,368	6 000	150	20 800
LUCR 40 PA <sup>n)</sup>	0,656	8 650	216	30 000
LUCR 50 PA <sup>n)</sup>	1,065	12 700	320	45 000
LUCR 60 PA <sup>n)</sup>	1,900	19 300	480	67 000
LUCR 80 PA <sup>n)</sup>	4,575	33 500	830	116 000

Items without letter footnote are usually available from stock.

<sup>n)</sup> Delivery time on request

<sup>s)</sup> Delivery time usually 10 days for max. quantity of 4; larger quantities on request

<sup>1)</sup> Basic load ratings are valid for bearing steel and stainless steel variants, but they must be reduced if stainless steel shafts are used

<sup>2)</sup> Linear bearings fitted to these units are secured with retaining rings according to DIN 471, cannot be relubricated and are not self-aligning

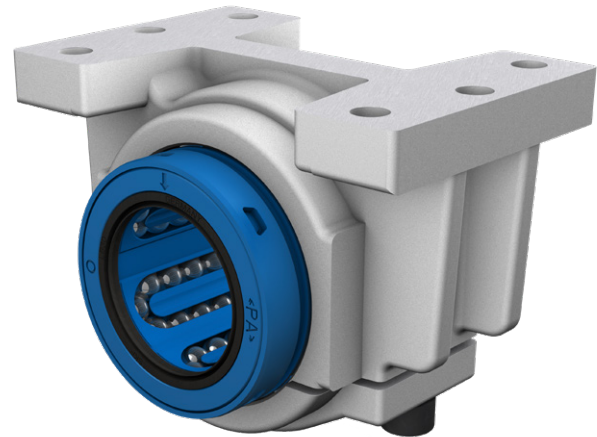
<sup>3)</sup> Valid if the loads on the housing are exclusively in direction of red arrow. See dimensional drawing on left page

### 3.4.2 Standard linear units - LUCS/LUCE

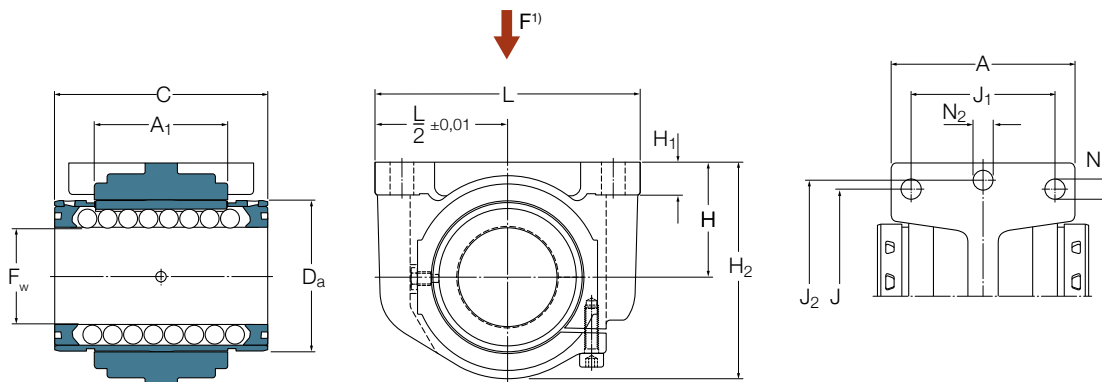
- LUCS with rigid LBCR bearing
- LUCE with self-aligning LBCD bearing

- Slotted design for adjustable clearance in sizes from 8 mm to 80 mm
- Lightweight die-cast aluminium housing
- Available in variants of 2 seals or 2 shields
- Available as bearing steel (standard) or stainless steel variant
- Factory pre-lubricated with SKF LGEP 2 grease, ready for use
- Equipped with grease fitting
- Able to bolt from top or bottom side

Please find suitable shaft blocks or shaft supports in **chapter3.6** and shafts in **chapter3.7**



Pictured is LUCE 30 D-2LS <sup>2)</sup>



Picture shows LUCE D with shields <sup>2)</sup>

Dimensions													
F <sub>w</sub>	A	A <sub>1</sub>	C	D <sub>a</sub>	H ±0,01	H <sub>1</sub>	H <sub>2</sub>	J	J <sub>1</sub>	J <sub>2</sub>	L <sup>3)</sup>	N <sup>4)</sup>	N <sub>2</sub> <sup>4)</sup>
mm													
8	27	14	25	16	15	5,5	28	25	20	35	45	3,2	5,3
12	31	20	32	22	18	6	34,5	32	23	42	52	4,3	5,3
16	34,5	22	36	26	22	7	40,5	40	26	46	56	4,3	5,3
20	41	28	45	32	25	8	48	45	32	58	70	4,3	6,4
25	52	40	58	40	30	10	58	60	40	68	80	5,3	6,4
30	59	48	68	47	35	10	67	68	45	76	88	6,4	6,4
40	74	56	80	62	45	12	85	86	58	94	108	8,4	8,4
50	66	72	100	75	50	14	99	108	50	116	135	8,4	10,5
60	84	95	125	90	60	18	118	132	65	138	160	10,5	13
80	113	125	165	120	80	22	158	170	90	180	205	13	13

<sup>1)</sup> Direction for max. load ratings

<sup>2)</sup> Picture with non D-series bearing or plain bearing differs

<sup>3)</sup> For units from size 50 to 80: Tolerance L/2 ±0,02

<sup>4)</sup> For cylinder head screws with internal hexagon according to ISO 4762



## LUCS

Designations				Mass kg	Basic load ratings <sup>1)</sup>			
LBCR bearing inside with shields		Stainless steel variant of LBCR bearing inside with 2 double lip seals			dynamic C		static C <sub>0</sub>	
-		-		min		max		
LUCS 8 <sup>2) s)</sup>	LUCS 8-2LS <sup>2) s)</sup>	LUCS 8/HV6 <sup>2) n)</sup>	LUCS 8-2LS/HV6 <sup>2) n)</sup>	0,028	490	570	355	500
LUCS 12 D <sup>s)</sup>	LUCS 12 D-2LS <sup>s)</sup>	LUCS 12 D/HV6 <sup>n)</sup>	LUCS 12 D-2LS/HV6 <sup>n)</sup>	0,058	930	1 370	695	1 120
LUCS 16 D <sup>s)</sup>	LUCS 16 D-2LS <sup>s)</sup>	LUCS 16 D/HV6 <sup>n)</sup>	LUCS 16 D-2LS/HV6 <sup>n)</sup>	0,077	1 080	1 600	800	1 290
LUCS 20 D <sup>s)</sup>	LUCS 20 D-2LS <sup>s)</sup>	LUCS 20 D/HV6 <sup>n)</sup>	LUCS 20 D-2LS/HV6 <sup>n)</sup>	0,160	2 200	3 250	1 630	2 650
LUCS 25 D <sup>s)</sup>	LUCS 25 D-2LS <sup>s)</sup>	LUCS 25 D/HV6 <sup>n)</sup>	LUCS 25 D-2LS/HV6 <sup>n)</sup>	0,310	3 100	4 550	2 360	3 800
LUCS 30 D <sup>s)</sup>	LUCS 30 D-2LS <sup>s)</sup>	LUCS 30 D/HV6 <sup>n)</sup>	LUCS 30 D-2LS/HV6 <sup>n)</sup>	0,452	4 800	7 100	3 550	5 700
LUCS 40 D <sup>s)</sup>	LUCS 40 D-2LS <sup>s)</sup>	LUCS 40 D/HV6 <sup>n)</sup>	LUCS 40 D-2LS/HV6 <sup>n)</sup>	0,795	7 650	11 200	5 100	8 300
LUCS 50 <sup>s)</sup>	LUCS 50-2LS <sup>s)</sup>	LUCS 50/HV6 <sup>n)</sup>	LUCS 50-2LS/HV6 <sup>n)</sup>	1,217	9 650	13 400	7 200	12 200
LUCS 60 <sup>s)</sup>	LUCS 60-2LS <sup>s)</sup>	LUCS 60/HV6 <sup>n)</sup>	LUCS 60-2LS/HV6 <sup>n)</sup>	2,191	14 600	20 400	11 200	18 000
LUCS 80 <sup>s)</sup>	LUCS 80-2LS <sup>s)</sup>	LUCS 80/HV6 <sup>n)</sup>	LUCS 80-2LS/HV6 <sup>n)</sup>	5,110	26 500	37 500	19 600	32 000

## LUCE

Designations				Mass kg	Basic load ratings <sup>1)</sup>			
Self-aligning LBCD bearing inside with shields		Stainless steel variant of self-aligning LBCD bearing inside with 2 double lip seals			dynamic C		static C <sub>0</sub>	
-		-		min		max		
LUCE 12 D <sup>s)</sup>	LUCE 12 D-2LS <sup>s)</sup>	LUCE 12 D/HV6 <sup>n)</sup>	LUCE 12 D-2LS/HV6 <sup>n)</sup>	0,058	800	1 220	570	930
LUCE 16 D <sup>s)</sup>	LUCE 16 D-2LS <sup>s)</sup>	LUCE 16 D/HV6 <sup>n)</sup>	LUCE 16 D-2LS/HV6 <sup>n)</sup>	0,076	950	1 400	655	1 060
LUCE 20 D <sup>s)</sup>	LUCE 20 D-2LS <sup>s)</sup>	LUCE 20 D/HV6 <sup>n)</sup>	LUCE 20 D-2LS/HV6 <sup>n)</sup>	0,159	1 730	2 550	1 120	1 800
LUCE 25 D <sup>s)</sup>	LUCE 25 D-2LS <sup>s)</sup>	LUCE 25 D/HV6 <sup>n)</sup>	LUCE 25 D-2LS/HV6 <sup>n)</sup>	0,308	2 600	3 800	1 430	2 320
LUCE 30 D <sup>s)</sup>	LUCE 30 D-2LS <sup>s)</sup>	LUCE 30 D/HV6 <sup>n)</sup>	LUCE 30 D-2LS/HV6 <sup>n)</sup>	0,450	3 800	5 600	2 320	3 750
LUCE 40 D <sup>s)</sup>	LUCE 40 D-2LS <sup>s)</sup>	LUCE 40 D/HV6 <sup>n)</sup>	LUCE 40 D-2LS/HV6 <sup>n)</sup>	0,788	6 550	9 650	3 350	5 700
LUCE 50 <sup>s)</sup>	LUCE 50-2LS <sup>s)</sup>	LUCE 50/HV6 <sup>n)</sup>	LUCE 50-2LS/HV6 <sup>n)</sup>	1,197	8 000	11 200	4 150	6 950

<sup>2)</sup> Delivery time on request<sup>3)</sup> Delivery time usually 10 days for max. quantity of 4; larger quantities on request<sup>1)</sup> Basic load ratings are valid for bearing steel and stainless steel variants, but they must be reduced if stainless steel shafts are used<sup>2)</sup> Linear ball bearings fitted to these units are secured with retaining rings according to DIN 471, cannot be relubricated and are not self-aligning

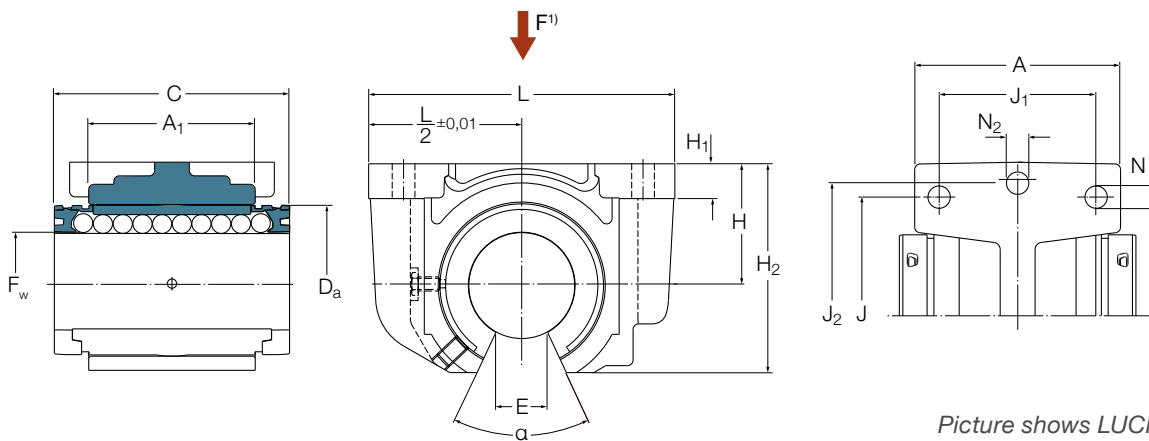
### 3.4.3 Standard linear units - LUCT/LUCF

- LUCT with rigid LBCT bearing
  - LUCF with self-aligning LBCF bearing
  - LUCT PA with LPAT linear plain bearing
- Open design in sizes from 12 mm to 80 mm with adjustable clearance
  - Lightweight die-cast aluminium housing
  - Available in variants of 2 seals or 2 shields
  - Available as bearing steel (standard) or stainless steel variant
  - Factory pre-lubricated with SKF LGEP 2 grease, ready for use
  - Equipped with grease fitting
  - Able to bolt from top or bottom side

Please find suitable shaft blocks or shaft supports in **chapter3.6** and shafts in **chapter3.7**



Pictured is LUCF 30 D-2LS <sup>2)</sup>



Picture shows LUCF D with shields <sup>2)</sup>

#### Dimensions

$F_w$	A	$A_1$	C	$D_a$	$H_{\pm 0,01}$	$H_1$	$H_2$	J	$J_1$	$J_2$	$L^{3)}$	$N^{4)}$	$N_2^{4)}$	$E^{5)}$	$\alpha$
mm															Deg.
12	31	20	32	22	18	6	28	32	23	42	52	4,3	5,3	7,6	78
16	34,5	22	36	26	22	7	35	40	26	46	56	4,3	5,3	10,4	78
20	41	28	45	32	25	8	42	45	32	58	70	4,3	6,4	10,8	60
25	52	40	58	40	30	10	51	60	40	68	80	5,3	6,4	13,2	60
30	59	48	68	47	35	10	60	68	45	76	88	6,4	6,4	14,2	50
40	74	56	80	62	45	12	77	86	58	94	108	8,4	8,4	18,7	50
50	66	72	100	75	50	14	88	108	50	116	135	8,4	10,5	23,6	50
60	84	95	125	90	60	18	105	132	65	138	160	10,5	13,0	29,6	54
80	113	125	165	120	80	22	140	170	90	180	205	13,0	13,0	38,4	54

<sup>1)</sup> Direction for max. load ratings

<sup>2)</sup> Picture with non D-series bearing or plain bearing differs

<sup>3)</sup> For units from size 50 to 80: Tolerance  $L/2 \pm 0,02$

<sup>4)</sup> For cylinder head screws with internal hexagon according to ISO 4762

<sup>5)</sup> Minimum sector width at diameter  $F_w$

## LUCT

Designations				Mass	Basic load ratings <sup>1)</sup>			
LBCT bearing inside		Stainless steel variant of LBCT bearing inside			dynamic C	static C <sub>0</sub>		
with shields	with 2 double lip seals	with shields	with 2 double lip seals	kg	min	max	min	max
–	–	–	–		N	–	–	–
LUCT 12 D <sup>s)</sup>	LUCT 12 D-2LS	LUCT 12 D/HV6 <sup>n)</sup>	LUCT 12 D-2LS/HV6 <sup>n)</sup>	0,050	695	1 220	510	1 020
LUCT 16 D <sup>s)</sup>	LUCT 16 D-2LS	LUCT 16 D/HV6 <sup>n)</sup>	LUCT 16 D-2LS/HV6 <sup>n)</sup>	0,065	765	1 500	585	1 370
LUCT 20 D <sup>s)</sup>	LUCT 20 D-2LS	LUCT 20 D/HV6 <sup>n)</sup>	LUCT 20 D-2LS/HV6 <sup>n)</sup>	0,138	1 860	3 200	1 340	2 700
LUCT 25 D <sup>s)</sup>	LUCT 25 D-2LS	LUCT 25 D/HV6 <sup>n)</sup>	LUCT 25 D-2LS/HV6 <sup>n)</sup>	0,269	2 700	4 650	2 000	4 000
LUCT 30 D <sup>s)</sup>	LUCT 30 D-2LS	LUCT 30 D/HV6 <sup>n)</sup>	LUCT 30 D-2LS/HV6 <sup>n)</sup>	0,396	4 150	7 200	3 000	6 000
LUCT 40 D <sup>u)</sup>	LUCT 40 D-2LS <sup>u)</sup>	LUCT 40 D/HV6 <sup>u)</sup>	LUCT 40 D-2LS/HV6 <sup>u)</sup>	0,681	6 400	11000	4 250	8 500
LUCT 50 <sup>s)</sup>	LUCT 50-2LS	LUCT 50/HV6 <sup>n)</sup>	LUCT 50-2LS/HV6 <sup>n)</sup>	1,055	5 850	13 400	5 300	12 200
LUCT 60 <sup>s)</sup>	LUCT 60-2LS <sup>s)</sup>	LUCT 60/HV6 <sup>n)</sup>	LUCT 60-2LS/HV6 <sup>n)</sup>	1,903	8 650	20 400	8 000	18 000
LUCT 80 <sup>s)</sup>	LUCT 80-2LS <sup>s)</sup>	LUCT 80/HV6 <sup>n)</sup>	LUCT 80-2LS/HV6 <sup>n)</sup>	4,531	16 000	37 500	14 000	32 000

## LUCF

Designations				Mass	Basic load ratings <sup>1)</sup>			
Self-aligning LBCF bearing inside		Stainless steel variant of self-aligning LBCF bearing inside			dynamic C	static C <sub>0</sub>		
with shields	with 2 double lip seals	with shields	with 2 double lip seals	kg	min	max	min	max
–	–	–	–		N	–	–	–
LUCF 12 D <sup>s)</sup>	LUCF 12 D-2LS	LUCF 12 D/HV6 <sup>n)</sup>	LUCF 12 D-2LS/HV6 <sup>n)</sup>	0,050	600	1 080	415	850
LUCF 16 D <sup>s)</sup>	LUCF 16 D-2LS	LUCF 16 D/HV6 <sup>n)</sup>	LUCF 16 D-2LS/HV6 <sup>n)</sup>	0,065	670	1 320	480	1 120
LUCF 20 D <sup>s)</sup>	LUCF 20 D-2LS	LUCF 20 D/HV6 <sup>n)</sup>	LUCF 20 D-2LS/HV6 <sup>n)</sup>	0,137	1 460	2 500	915	1 830
LUCF 25 D <sup>s)</sup>	LUCF 25 D-2LS	LUCF 25 D/HV6 <sup>n)</sup>	LUCF 25 D-2LS/HV6 <sup>n)</sup>	0,267	2 280	3 900	1 220	2 450
LUCF 30 D <sup>s)</sup>	LUCF 30 D-2LS	LUCF 30 D/HV6 <sup>n)</sup>	LUCF 30 D-2LS/HV6 <sup>n)</sup>	0,394	3 250	5 700	1 960	3 900
LUCF 40 D <sup>u)</sup>	LUCF 40 D-2LS <sup>u)</sup>	LUCF 40 D/HV6 <sup>u)</sup>	LUCF 40 D-2LS/HV6 <sup>u)</sup>	0,677	5 500	9 500	3 000	5 850
LUCF 50 <sup>s)</sup>	LUCF 50-2LS	LUCF 50/HV6 <sup>n)</sup>	LUCF 50-2LS/HV6 <sup>n)</sup>	1,035	4 900	11 200	3 000	6 950

## LUCT PA

Designations	Mass	Basic load ratings		static <sup>2)</sup> C <sub>0</sub>
		dynamic C	dynamic C	
LPAT linear plain bearing inside		at 0,1 m/s	at 4 m/s	
–	kg	N		
LUCT 12 PA <sup>n)</sup>	0,042	1 060	26	3 650
LUCT 16 PA <sup>n)</sup>	0,057	1 680	43	5 850
LUCT 20 PA <sup>n)</sup>	0,115	2 700	68	9 500
LUCT 25 PA <sup>n)</sup>	0,225	4 400	110	15 300
LUCT 30 PA <sup>n)</sup>	0,328	6 000	150	20 800
LUCT 40 PA <sup>n)</sup>	0,564	8 650	216	30 000
LUCT 50 PA <sup>n)</sup>	0,935	12 700	320	45 000
LUCT 60 PA <sup>n)</sup>	1,663	19 300	480	67 000
LUCT 80 PA <sup>n)</sup>	3,981	33 500	830	116 000

Items without letter footnote are usually available from stock.

<sup>n)</sup> Delivery time on request

<sup>s)</sup> Delivery time usually 10 days for max. quantity of 4; larger quantities on request

<sup>u)</sup> Size 40 under development; A-design unit is available until replacement

<sup>1)</sup> Basic load ratings are valid for bearing steel and stainless steel variants, but they must be reduced if stainless steel shafts are used

<sup>2)</sup> Valid if the loads onto the housing are exclusively in direction of red arrow. See dimensional drawing on left page

### 3.4.4 Standard linear units - LUCT BH

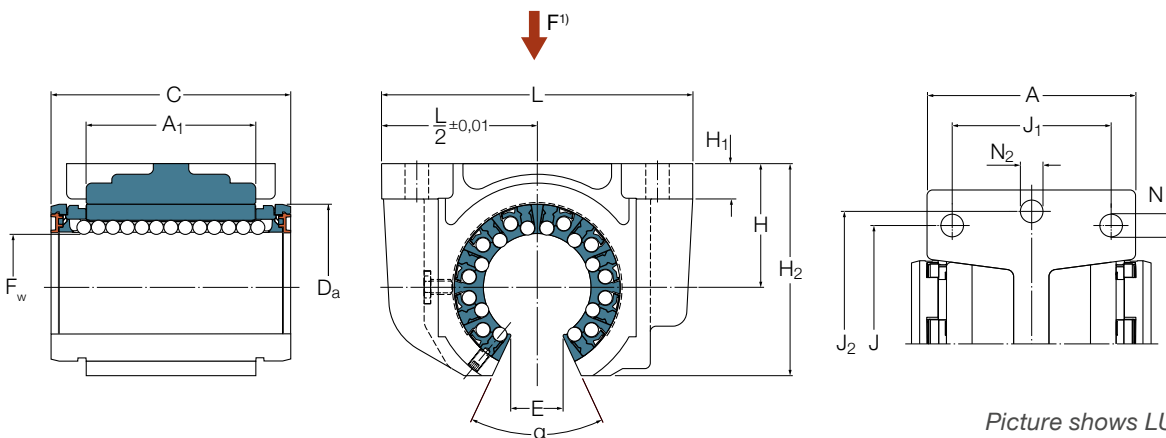
- LUCT BH with rigid LBHT heavy duty bearing

- Open heavy duty design in sizes from 20 mm to 50 mm
- Lightweight die-cast aluminium housing
- Available in variants of 2 seals or 2 shields
- Available as bearing steel (standard) or stainless steel variant
- Factory pre-lubricated with SKF LGEP 2 grease, ready for use
- Equipped with grease fitting
- Able to bolt from top or bottom side

Please find suitable shaft blocks or shaft supports in **chapter3.6** and shafts in **chapter3.7**



Pictured is LUCT 30 BH-2LS <sup>2)</sup>



Picture shows LUCT BH with shields

Dimensions															
F <sub>w</sub>	A	A <sub>1</sub>	C	D <sub>a</sub>	H ±0,01	H <sub>1</sub>	H <sub>2</sub>	J	J <sub>1</sub>	J <sub>2</sub>	L <sup>2)</sup>	N <sup>3)</sup>	N <sub>2</sub> <sup>3)</sup>	E <sup>4)</sup>	α
mm															Deg.
20	41	28	45	32	25	8	42	45	32	58	70	4,3	6,4	10,8	60,0
25	52	40	58	40	30	10	51	60	40	68	80	5,3	6,4	13,2	60,0
30	59	48	68	47	35	10	60	68	45	76	88	6,4	6,4	14,2	50,0
40	74	56	80	62	45	12	77	86	58	94	108	8,4	8,4	18,7	50,0
50	66	72	100	75	50	14	88	108	50	116	135	8,4	10,5	23,6	50,0

<sup>1)</sup> Direction for max. load ratings

<sup>2)</sup> For units from size 50: Tolerance L/2 ± 0,02

<sup>3)</sup> For cylinder head screws with internal hexagon according to ISO 4762

<sup>4)</sup> Minimum sector width at diameter F<sub>w</sub>

## LUCT BH

Designations				Mass	Basic load ratings <sup>1)</sup>			
LBHT bearing inside		Stainless steel variant of LBHT bearing inside			dynamic C	static C <sub>0</sub>		
with shields	with 2 double lip seals	with shields	with 2 double lip seals	kg	min	max	min	max
–					N			
LUCT 20 BH <sup>n)</sup>	LUCT 20 BH-2LS <sup>s)</sup>	LUCT 20 BH/HV6 <sup>n)</sup>	LUCT 20 BH-2LS/HV6 <sup>n)</sup>	0,14	1 460	2 650	1 430	2 650
LUCT 25 BH <sup>n)</sup>	LUCT 25 BH-2LS <sup>s)</sup>	LUCT 25 BH/HV6 <sup>n)</sup>	LUCT 25 BH-2LS/HV6 <sup>n)</sup>	0,275	2 200	4 900	2 240	5 100
LUCT 30 BH <sup>n)</sup>	LUCT 30 BH-2LS <sup>s)</sup>	LUCT 30 BH/HV6 <sup>n)</sup>	LUCT 30 BH-2LS/HV6 <sup>n)</sup>	0,48	4 250	7 200	4 300	8 000
LUCT 40 BH <sup>n)</sup>	LUCT 40 BH-2LS <sup>s)</sup>	LUCT 40 BH/HV6 <sup>n)</sup>	LUCT 40 BH-2LS/HV6 <sup>n)</sup>	0,86	6 950	11 600	6 300	11 400
LUCT 50 BH <sup>n)</sup>	LUCT 50 BH-2LS <sup>s)</sup>	LUCT 50 BH/HV6 <sup>n)</sup>	LUCT 50 BH-2LS/HV6 <sup>n)</sup>	1,44	10 200	17 300	9 300	17 000

Items without letter footnote are usually available from stock.

<sup>n)</sup> Delivery time on request

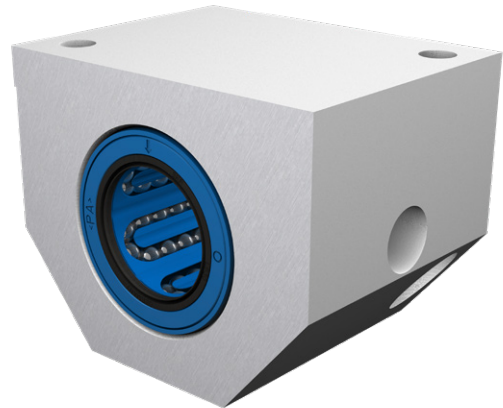
<sup>s)</sup> Delivery time usually 10 days for max. quantity of 4; larger quantities on request

<sup>1)</sup> Basic load ratings are valid for bearing steel and stainless steel variants, but they must be reduced if stainless steel shafts are used

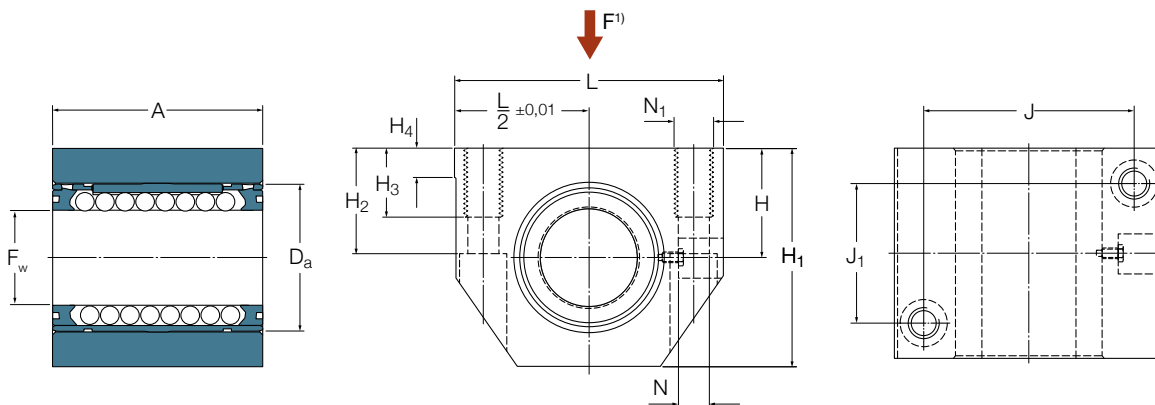
### 3.4.5 Standard linear units - LUNR/LUND

- LUNR with rigid LBCR bearing
  - LUND with self-aligning LBCD bearing
  - LUNR PA with LPAR linear plain bearing
- Closed design in sizes from 12 mm to 50 mm
  - Aluminium housing covers the entire bearing length
  - Available in variants of 2 seals or 2 shields
  - Available as bearing steel (standard) or stainless steel variant
  - Factory pre-lubricated with SKF LGEP 2 grease, ready for use
  - Equipped with grease fitting
  - Able to bolt from top or bottom side

Please find suitable shaft blocks or shaft supports in **chapter3.6** and shafts in **chapter3.7**



Pictured is LUND 30 D-2LS <sup>2)</sup>



Picture shows LUND D with shields <sup>2)</sup>

Dimensions												
F <sub>w</sub>	A	D <sub>a</sub>	H ±0,01	H <sub>1</sub>	H <sub>2</sub>	H <sub>3</sub>	H <sub>4</sub>	J	J <sub>1</sub>	L	N <sup>3)</sup>	N <sub>1</sub>
mm												-
12	32	22	18	35	16,5	11	6	32	23	43	4,3	M5
16	37	26	22	42	21	13	7	40	26	53	5,3	M6
20	45	32	25	50	24	18	7,5	45	32	60	6,6	M8
25	58	40	30	61	29	22	8,5	60	40	78	8,4	M10
30	68	47	35	70	34	22	9,5	68	45	87	8,4	M10
40	80	62	45	90	44	26	11	86	58	108	10,5	M12
50	100	75	50	105	49	35	11	108	50	132	13,5	M16

<sup>1)</sup> Direction for max. load ratings

<sup>2)</sup> Picture with non D-series bearing or plain bearing differs

<sup>3)</sup> For cylinder head screws with internal hexagon according to ISO 4762

## LUNR

Designations				Mass kg	Basic load ratings <sup>1)</sup>			
LBCR bearing inside with shields		Stainless steel variant of LBCR bearing inside with 2 double lip seals			dynamic C		static C <sub>0</sub>	
-		-		min N		max		
LUNR 12 D <sup>n)</sup>	LUNR 12 D-2LS <sup>n)</sup>	LUNR 12 D/HV6 <sup>n)</sup>	LUNR 12 D-2LS/HV6 <sup>n)</sup>	0,100	930	1 370	695	1 120
LUNR 16 D <sup>n)</sup>	LUNR 16 D-2LS <sup>n)</sup>	LUNR 16 D/HV6 <sup>n)</sup>	LUNR 16 D-2LS/HV6 <sup>n)</sup>	0,170	1 080	1 600	800	1 290
LUNR 20 D <sup>n)</sup>	LUNR 20 D-2LS <sup>n)</sup>	LUNR 20 D/HV6 <sup>n)</sup>	LUNR 20 D-2LS/HV6 <sup>n)</sup>	0,273	2 200	3 250	1 630	2 650
LUNR 25 D <sup>n)</sup>	LUNR 25 D-2LS <sup>n)</sup>	LUNR 25 D/HV6 <sup>n)</sup>	LUNR 25 D-2LS/HV6 <sup>n)</sup>	0,554	3 100	4 550	2 360	3 800
LUNR 30 D <sup>n)</sup>	LUNR 30 D-2LS <sup>n)</sup>	LUNR 30 D/HV6 <sup>n)</sup>	LUNR 30 D-2LS/HV6 <sup>n)</sup>	0,827	4 800	7 100	3 550	5 700
LUNR 40 D <sup>n)</sup>	LUNR 40 D-2LS <sup>n)</sup>	LUNR 40 D/HV6 <sup>n)</sup>	LUNR 40 D-2LS/HV6 <sup>n)</sup>	1,501	7 650	11 200	5 100	8 300
LUNR 50 <sup>n)</sup>	LUNR 50-2LS <sup>n)</sup>	LUNR 50/HV6 <sup>n)</sup>	LUNR 50-2LS/HV6 <sup>n)</sup>	2,498	9 650	13 400	7 200	12 200

## LUND

Designations				Mass kg	Basic load ratings <sup>1)</sup>			
Self-aligning LBCD bearing inside with shields		Stainless steel variant of self-aligning LBCD bearing inside with 2 double lip seals			dynamic C		static C <sub>0</sub>	
-		-		min N		max		
LUND 12 D <sup>s)</sup>	LUND 12 D-2LS	LUND 12 D/HV6 <sup>n)</sup>	LUND 12 D-2LS/HV6 <sup>n)</sup>	0,100	800	1 220	570	930
LUND 16 D <sup>s)</sup>	LUND 16 D-2LS	LUND 16D/HV6 <sup>n)</sup>	LUND 16 D-2LS/HV6 <sup>n)</sup>	0,169	950	1 400	655	1 060
LUND 20 D <sup>s)</sup>	LUND 20 D-2LS	LUND 20D/HV6 <sup>n)</sup>	LUND 20 D-2LS/HV6 <sup>n)</sup>	0,272	1 730	2 550	1 120	1 800
LUND 25 D <sup>s)</sup>	LUND 25 D-2LS	LUND 25D/HV6 <sup>n)</sup>	LUND 25 D-2LS/HV6 <sup>n)</sup>	0,552	2 600	3 800	1 430	2 320
LUND 30 D <sup>s)</sup>	LUND 30 D-2LS	LUND 30 D/HV6 <sup>n)</sup>	LUND 30 D-2LS/HV6 <sup>n)</sup>	0,825	3 800	5 600	2 320	3 750
LUND 40 D <sup>s)</sup>	LUND 40 D-2LS	LUND 40 D/HV6 <sup>n)</sup>	LUND 40 D-2LS/HV6 <sup>n)</sup>	1,494	6 550	9 650	3 350	5 700
LUND 50 <sup>s)</sup>	LUND 50-2LS	LUND 50/HV6 <sup>n)</sup>	LUND 50-2LS/HV6 <sup>n)</sup>	2,478	8 000	11 200	4 150	6 950

## LUNR PA

Designations	Mass kg	Basic load ratings		static <sup>2)</sup> C <sub>0</sub>
		dynamic C at 0,1 m/s N	at 4 m/s	
LUNR 12 PA <sup>n)</sup>	0,09	1 060	26	3 650
LUNR 16 PA <sup>n)</sup>	0,159	1 680	43	5 850
LUNR 20 PA <sup>n)</sup>	0,245	2 700	68	9 500
LUNR 25 PA <sup>n)</sup>	0,501	4 400	110	15 300
LUNR 30 PA <sup>n)</sup>	0,745	6 000	150	20 800
LUNR 40 PA <sup>n)</sup>	1,358	8 650	216	30 000
LUNR 50 PA <sup>n)</sup>	2,348	12 700	320	45 000

Items without letter footnote are usually available from stock.

<sup>n)</sup> Delivery time on request

<sup>s)</sup> Delivery time usually 10 days for max. quantity of 4; larger quantities on request

<sup>1)</sup> Basic load ratings are valid for bearing steel and stainless steel variants, but they must be reduced if stainless steel shafts are used

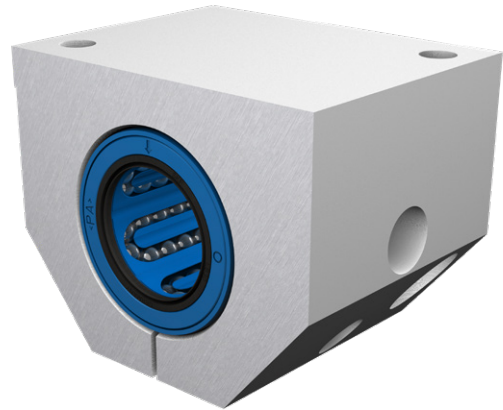
<sup>2)</sup> Valid if the loads onto the housing are exclusively in direction of red arrow. See dimensional drawing on left page

### 3.4.6 Standard linear units - LUNS/LUNE

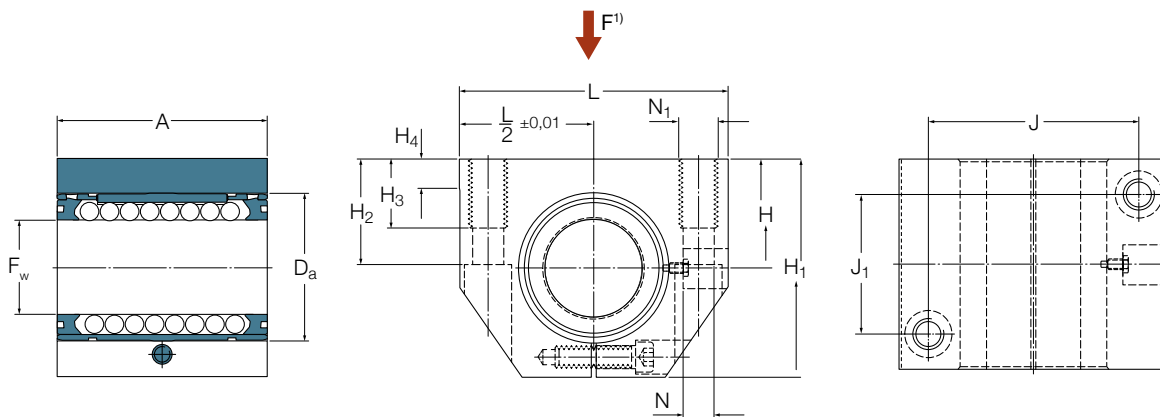
- LUNS with rigid LBCR bearing
- LUNE with self-aligning LBCD bearing

- Slotted design for adjustable clearance in sizes from 12 mm to 50 mm
- Aluminium housing covers the entire bearing length
- Available in variants of 2 seals or 2 shields
- Available as bearing steel (standard) or stainless-steel variant
- Factory pre-lubricated with SKF LGEP 2 grease, ready for use
- Equipped with grease fitting
- Able to bolt from top or bottom side

Please find suitable shaft blocks or shaft supports in **chapter3.6** and shafts in **chapter3.7**



Pictured is LUNE 30 D-2LS <sup>2)</sup>



Picture shows LUNE D with shields <sup>2)</sup>

Dimensions												
F <sub>w</sub>	A	D <sub>a</sub>	H ±0,01	H <sub>1</sub>	H <sub>2</sub>	H <sub>3</sub>	H <sub>4</sub>	J	J <sub>1</sub>	L	N <sup>3)</sup>	N <sub>1</sub>
mm												-
12	32	22	18	35	16,5	11	6	32	23	43	4,3	M5
16	37	26	22	42	21	13	7	40	26	53	5,3	M6
20	45	32	25	50	24	18	7,5	45	32	60	6,6	M8
25	58	40	30	61	29	22	8,5	60	40	78	8,4	M10
30	68	47	35	70	34	22	9,5	68	45	87	8,4	M10
40	80	62	45	90	44	26	11	86	58	108	10,5	M12
50	100	75	50	105	49	35	11	108	50	132	13,5	M16

<sup>1)</sup> Direction for max. load ratings

<sup>2)</sup> Picture with non D-series bearing or plain bearing differs

<sup>3)</sup> For cylinder head screws with internal hexagon according to ISO 4762



## LUNS

Designations				Mass kg	Basic load ratings <sup>1)</sup>			
LBCR bearing inside with shields		Stainless steel variant of LBCR bearing inside with 2 double lip seals			dynamic C		static C <sub>0</sub>	
with shields	with 2 double lip seals	with shields	with 2 double lip seals	min	max	min	max	
–								
LUNS 12 D <sup>n)</sup>	LUNS 12 D-2LS <sup>n)</sup>	LUNS 12 D/HV6 <sup>n)</sup>	LUNS 12 D-2LS/HV6 <sup>n)</sup>	0,100	930	1 370	695	1 120
LUNS 16 D <sup>n)</sup>	LUNS 16 D-2LS <sup>n)</sup>	LUNS 16 D/HV6 <sup>n)</sup>	LUNS 16 D-2LS/HV6 <sup>n)</sup>	0,170	1 080	1 600	800	1 290
LUNS 20 D <sup>n)</sup>	LUNS 20 D-2LS <sup>n)</sup>	LUNS 20 D/HV6 <sup>n)</sup>	LUNS 20 D-2LS/HV6 <sup>n)</sup>	0,273	2 200	3 250	1 630	2 650
LUNS 25 D <sup>n)</sup>	LUNS 25 D-2LS <sup>n)</sup>	LUNS 25 D/HV6 <sup>n)</sup>	LUNS 25 D-2LS/HV6 <sup>n)</sup>	0,554	3 100	4 550	2 360	3 800
LUNS 30 D <sup>n)</sup>	LUNS 30 D-2LS <sup>n)</sup>	LUNS 30 D/HV6 <sup>n)</sup>	LUNS 30 D-2LS/HV6 <sup>n)</sup>	0,827	4 800	7 100	3 550	5 700
LUNS 40 D <sup>n)</sup>	LUNS 40 D-2LS <sup>n)</sup>	LUNS 40 D/HV6 <sup>n)</sup>	LUNS 40 D-2LS/HV6 <sup>n)</sup>	1,501	7 650	11 200	5 100	8 300
LUNS 50 <sup>n)</sup>	LUNS 50-2LS <sup>n)</sup>	LUNS 50/HV6 <sup>n)</sup>	LUNS 50-2LS/HV6 <sup>n)</sup>	2,498	9 650	13 400	7 200	12 200

## LUNE

Designations				Mass kg	Basic load ratings <sup>1)</sup>			
Self-aligning LBCD bearing inside with shields		Stainless steel variant of self-aligning LBCD bearing inside with 2 double lip seals			dynamic C		static C <sub>0</sub>	
with shields	with 2 double lip seals	with shields	with 2 double lip seals	min	max	min	max	
–								
LUNE 12 D <sup>s)</sup>	LUNE 12 D-2LS	LUNE 12 D/HV6 <sup>n)</sup>	LUNE 12 D-2LS/HV6 <sup>n)</sup>	0,100	800	1 220	570	930
LUNE 16 D <sup>s)</sup>	LUNE 16 D-2LS	LUNE 16 D/HV6 <sup>n)</sup>	LUNE 16 D-2LS/HV6 <sup>n)</sup>	0,169	950	1 400	655	1 060
LUNE 20 D <sup>s)</sup>	LUNE 20 D-2LS	LUNE 20 D/HV6 <sup>n)</sup>	LUNE 20 D-2LS/HV6 <sup>n)</sup>	0,272	1 730	2 550	1 120	1 800
LUNE 25 D <sup>s)</sup>	LUNE 25 D-2LS	LUNE 25 D/HV6 <sup>n)</sup>	LUNE 25 D-2LS/HV6 <sup>n)</sup>	0,552	2 600	3 800	1 430	2 320
LUNE 30 D <sup>s)</sup>	LUNE 30 D-2LS	LUNE 30 D/HV6 <sup>n)</sup>	LUNE 30 D-2LS/HV6 <sup>n)</sup>	0,825	3 800	5 600	2 320	3 750
LUNE 40 D <sup>s)</sup>	LUNE 40 D-2LS	LUNE 40 D/HV6 <sup>n)</sup>	LUNE 40 D-2LS/HV6 <sup>n)</sup>	1,494	6 550	9 650	3 350	5 700
LUNE 50 <sup>s)</sup>	LUNE 50-2LS	LUNE 50/HV6 <sup>n)</sup>	LUNE 50-2LS/HV6 <sup>n)</sup>	2,478	8 000	11 200	4 150	6 950

Items without letter footnote are usually available from stock.

<sup>n)</sup> Delivery time on request

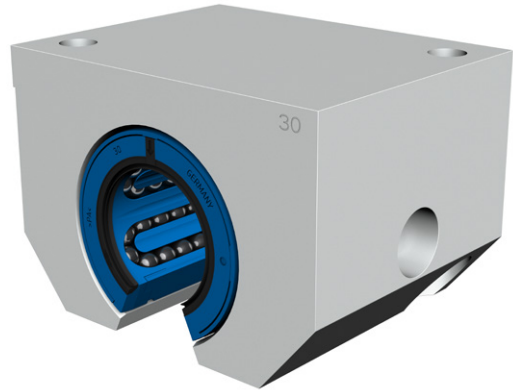
<sup>s)</sup> Delivery time usually 10 days for max. quantity of 4; larger quantities on request

<sup>1)</sup> Basic load ratings are valid for bearing steel and stainless steel variants, but they must be reduced if stainless steel shafts are used

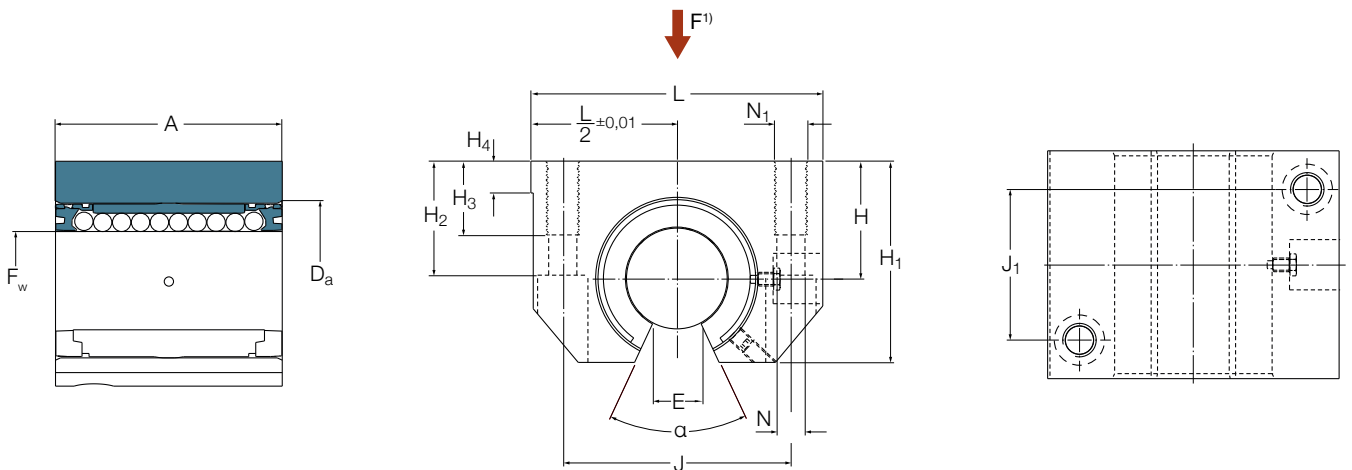
### 3.4.7 Standard linear units - LUNT/LUNF

- LUNT with rigid LBCT bearing
  - LUNF with self-aligning LBCF bearing
  - LUNT PA with LPAT linear plain bearing
- Open design in sizes from 12 mm to 50 mm
  - Aluminium housing covers the entire bearing length
  - Available in variants of 2 seals or 2 shields
  - Available as bearing steel (standard) or stainless steel variant
  - Factory pre-lubricated with SKF LGEP 2 grease, ready for use
  - Equipped with grease fitting
  - Able to bolt from top or bottom side

Please find suitable shaft blocks or shaft supports in **chapter3.6** and shafts in **chapter3.7**



Pictured is LUNF 30 D-2LS <sup>2)</sup>



Picture shows LUNF D with shields <sup>2)</sup>

Dimensions														
F <sub>w</sub>	A	D <sub>a</sub>	H ±0,01	H <sub>1</sub>	H <sub>2</sub>	H <sub>3</sub>	H <sub>4</sub>	J	J <sub>1</sub>	L	N <sup>3)</sup>	N <sub>1</sub>	E <sup>4)</sup>	α
mm												-	mm	Deg.
12	32	22	18	28	16,5	11	6	32	23	43	4,3	M5	7,6	78
16	37	26	22	35	21	13	7	40	26	53	5,3	M6	10,4	78
20	45	32	25	42	24	18	7,5	45	32	60	6,6	M8	10,8	60
25	58	40	30	51	29	22	8,5	60	40	78	8,4	M10	13,2	60
30	68	47	35	60	34	22	9,5	68	45	87	8,4	M10	14,2	50
40	80	62	45	77	44	26	11	86	58	108	10,5	M12	18,7	50
50	100	75	50	88	49	35	11	108	50	132	13,5	M16	23,6	50

<sup>1)</sup> Direction for max. load ratings

<sup>2)</sup> Picture with non D-series bearing or plain bearing differs

<sup>3)</sup> For cylinder head screws with internal hexagon according to ISO 4762

<sup>4)</sup> Minimum sector width at diameter F<sub>w</sub>

## LUNT

Designations				Mass kg	Basic load ratings <sup>1)</sup>			
LBCT bearing inside with shields		Stainless steel variant of LBCT bearing inside with 2 double lip seals			dynamic C		static C <sub>0</sub>	
-		-		min N		max		
LUNT 12 D <sup>n)</sup>	LUNT 12 D-2LS <sup>n)</sup>	LUNT 12 D/HV6 <sup>n)</sup>	LUNT 12 D-2LS/HV6 <sup>n)</sup>	0,080	695	1 220	510	1 020
LUNT 16 D <sup>n)</sup>	LUNT 16 D-2LS <sup>n)</sup>	LUNT 16 D/HV6 <sup>n)</sup>	LUNT 16 D-2LS/HV6 <sup>n)</sup>	0,138	765	1 500	585	1 370
LUNT 20 D <sup>n)</sup>	LUNT 20 D-2LS <sup>n)</sup>	LUNT 20 D/HV6 <sup>n)</sup>	LUNT 20 D-2LS/HV6 <sup>n)</sup>	0,225	1 860	3 200	1 340	2 700
LUNT 25 D <sup>n)</sup>	LUNT 25 D-2LS <sup>n)</sup>	LUNT 25 D/HV6 <sup>n)</sup>	LUNT 25 D-2LS/HV6 <sup>n)</sup>	0,462	2 700	4 650	2 000	4 000
LUNT 30 D <sup>n)</sup>	LUNT 30 D-2LS <sup>n)</sup>	LUNT 30 D/HV6 <sup>n)</sup>	LUNT 30 D-2LS/HV6 <sup>n)</sup>	0,696	4 150	7 200	3 000	6 000
LUNT 40 D <sup>u)</sup>	LUNT 40 D-2LS <sup>u)</sup>	LUNT 40 D/HV6 <sup>u)</sup>	LUNT 40 D-2LS/HV6 <sup>u)</sup>	1,260	6 400	11 000	4 250	8 500
LUNT 50 <sup>n)</sup>	LUNT 50-2LS <sup>n)</sup>	LUNT 50/HV6 <sup>n)</sup>	LUNT 50-2LS/HV6 <sup>n)</sup>	2,041	5 850	13 400	5 300	12 200

## LUNF

Designations				Mass kg	Basic load ratings <sup>1)</sup>			
Self-aligning LBCF bearing inside with shields		Stainless steel variant of self-aligning LBCF bearing inside with 2 double lip seals			dynamic C		static C <sub>0</sub>	
-		-		min N		max		
LUNF 12 D <sup>s)</sup>	LUNF 12 D-2LS	LUNF 12 D/HV6 <sup>s)</sup>	LUNF 12 D-2LS/HV6 <sup>s)</sup>	0,080	600	1 080	415	850
LUNF 16 D <sup>s)</sup>	LUNF 16 D-2LS	LUNF 16 D/HV6 <sup>s)</sup>	LUNF 16 D-2LS/HV6 <sup>s)</sup>	0,138	670	1 320	480	1 120
LUNF 20 D <sup>s)</sup>	LUNF 20 D-2LS	LUNF 20 D/HV6 <sup>s)</sup>	LUNF 20 D-2LS/HV6 <sup>s)</sup>	0,224	1 460	2 500	915	1 830
LUNF 25 D <sup>s)</sup>	LUNF 25 D-2LS	LUNF 25 D/HV6 <sup>s)</sup>	LUNF 25 D-2LS/HV6 <sup>s)</sup>	0,460	2 280	3 900	1 220	2 450
LUNF 30 D <sup>s)</sup>	LUNF 30 D-2LS	LUNF 30 D/HV6 <sup>s)</sup>	LUNF 30 D-2LS/HV6 <sup>s)</sup>	0,694	3 250	5 700	1 960	3 900
LUNF 40 D <sup>u)</sup>	LUNF 40 D-2LS <sup>u)</sup>	LUNF 40 D/HV6 <sup>u)</sup>	LUNF 40 D-2LS/HV6 <sup>u)</sup>	1,256	5 500	9 500	3 000	5 850
LUNF 50 <sup>s)</sup>	LUNF 50-2LS	LUNF 50/HV6 <sup>s)</sup>	LUNF 50-2LS/HV6 <sup>s)</sup>	2,021	4 900	11 200	3 000	6 950

## LUNT PA

Designations	Mass kg	Basic load ratings		static <sup>2)</sup> C <sub>0</sub>
		dynamic C at 0,1 m/s N	at 4 m/s	
LPAT linear plain bearing inside				
-				
LUNT 12 PA <sup>n)</sup>	0,072	1 060	26	3 650
LUNT 16 PA <sup>n)</sup>	0,130	1 680	43	5 850
LUNT 20 PA <sup>n)</sup>	0,202	2 700	68	9 500
LUNT 25 PA <sup>n)</sup>	0,418	4 400	110	15 300
LUNT 30 PA <sup>n)</sup>	0,628	6 000	150	20 800
LUNT 40 PA <sup>n)</sup>	1,143	8 650	216	30 000
LUNT 50 PA <sup>n)</sup>	1,921	12 700	320	45 000

Items without letter footnote are usually available from stock.

<sup>n)</sup> Delivery time on request

<sup>s)</sup> Delivery time usually 10 days for max. quantity of 4; larger quantities on request

<sup>u)</sup> Size 40 under development; A-design unit is available until replacement

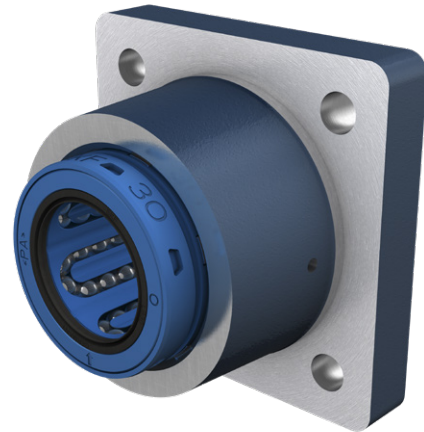
<sup>1)</sup> Basic load ratings are valid for bearing steel and stainless steel variants, but they must be reduced if stainless steel shafts are used

<sup>2)</sup> Valid if the loads onto the housing are exclusively in direction of red arrow. See dimensional drawing on left page

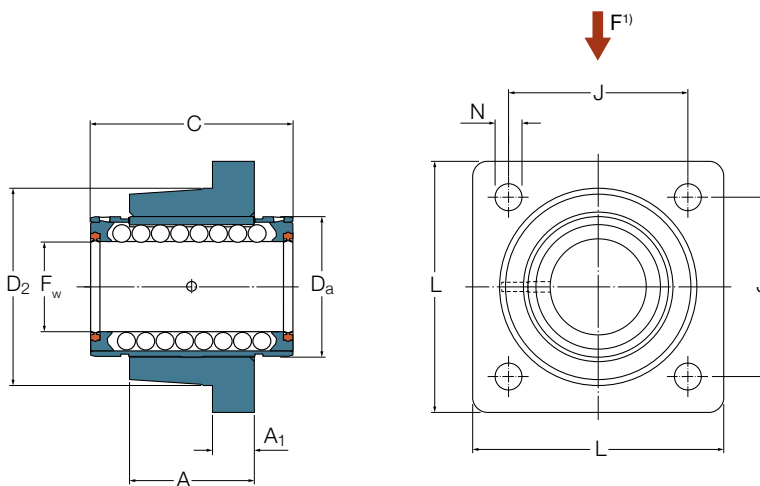
### 3.4.8 Standard flanged units - LVCR/LVCD

- LVCR with rigid LBCR bearing
  - LVCD with self-aligning LBCD bearing
  - LVCR PA with LPAR linear plain bearing
- Flanged design in sizes from 12 mm to 80 mm
  - Cast iron housing for high rigidity
  - Available in variants of 2 seals or 2 shields
  - Available as bearing steel (standard) or stainless-steel variant
  - Factory pre-lubricated with SKF LGEP 2 grease, ready for use
  - Relubrication via the shaft surface
  - Flexible to bolt from either side of the flange surface

Please find suitable shaft blocks or shaft supports in **chapter3.6** and shafts in **chapter3.7**



*Pictured is LVCR 30 D-2LS 2)*



*Picture shows LVCR with 2 double lip seals 2)*

Dimensions								
F <sub>w</sub> mm	A	A <sub>1</sub>	C	D <sub>a</sub>	D <sub>2</sub>	J	L	N <sup>3)</sup>
12	20	8	32	22	32	30	42	5,5
16	22	8	36	26	38	35	50	5,5
20	28	10	45	32	46	42	60	6,6
25	40	12	58	40	58	54	74	6,6
30	48	14	68	47	66	60	84	9
40	56	16	80	62	90	78	108	11
50	72	18	100	75	110	98	130	11
60	95	22	125	90	135	120	160	13,5
80	125	25	165	120	180	155	200	13,5

<sup>1)</sup> Direction for max. load ratings

<sup>2)</sup> Picture with non D-series bearing or plain bearing differs

<sup>3)</sup> For cylinder head screws with internal hexagon according to ISO 4762

## LVCR

Designations			Mass	Basic load ratings <sup>1)</sup>			
LBCR bearing inside with shields	with 2 double lip seals	Stainless steel variant of LBCR bearing inside with 2 double lip seals		dynamic C	max	static C <sub>0</sub>	max
–			kg	min	N	min	max
LVCR 12 D <sup>s)</sup>	LVCR 12 D-2LS	LVCR 12 D-2LS/HV6 <sup>n)</sup>	0,117	930	1 370	695	1 120
LVCR 16 D <sup>s)</sup>	LVCR 16 D-2LS	LVCR 16 D-2LS/HV6 <sup>n)</sup>	0,171	1 080	1 600	800	1 290
LVCR 20 D <sup>s)</sup>	LVCR 20 D-2LS	LVCR 20 D-2LS/HV6 <sup>n)</sup>	0,326	2 200	3 250	1 630	2 650
LVCR 25 D <sup>s)</sup>	LVCR 25 D-2LS	LVCR 25 D-2LS/HV6 <sup>n)</sup>	0,676	3 100	4 550	2 360	3 800
LVCR 30 D <sup>s)</sup>	LVCR 30 D-2LS	LVCR 30 D-2LS/HV6 <sup>n)</sup>	1,032	4 800	7 100	3 550	5 700
LVCR 40 D <sup>s)</sup>	LVCR 40 D-2LS	LVCR 40 D-2LS/HV6 <sup>n)</sup>	1,973	7 650	11 200	5 100	8 300
LVCR 50 <sup>s)</sup>	LVCR 50-2LS	LVCR 50-2LS/HV6 <sup>n)</sup>	3,294	9 650	13 400	7 200	12 200
LVCR 60 <sup>s)</sup>	LVCR 60-2LS <sup>s)</sup>	LVCR 60-2LS/HV6 <sup>n)</sup>	5,920	14 600	20 400	11 200	18 000
LVCR 80 <sup>s)</sup>	LVCR 80-2LS <sup>s)</sup>	LVCR 80-2LS/HV6 <sup>n)</sup>	13,300	26 500	37 500	19 600	32 000

## LVCD

Designations			Mass	Basic load ratings <sup>1)</sup>			
Self-aligning LVCD bearing inside with shields	with 2 double lip seals	Stainless steel variant of self-aligning LVCD bearing inside with 2 double lip seals		dynamic C	max	static C <sub>0</sub>	max
–			kg	min	N	min	max
LVCD 12 D <sup>n)</sup>	LVCD 12 D-2LS <sup>s)</sup>	LVCD 12 D-2LS/HV6 <sup>n)</sup>	0,117	800	1 220	570	930
LVCD 16 D <sup>n)</sup>	LVCD 16 D-2LS <sup>s)</sup>	LVCD 16 D-2LS/HV6 <sup>n)</sup>	0,170	950	1 400	655	1 060
LVCD 20 D <sup>n)</sup>	LVCD 20 D-2LS <sup>s)</sup>	LVCD 20 D-2LS/HV6 <sup>n)</sup>	0,325	1 730	2 550	1 120	1 800
LVCD 25 D <sup>n)</sup>	LVCD 25 D-2LS <sup>s)</sup>	LVCD 25 D-2LS/HV6 <sup>n)</sup>	0,674	2 600	3 800	1 430	2 320
LVCD 30 D <sup>n)</sup>	LVCD 30 D-2LS <sup>s)</sup>	LVCD 30 D-2LS/HV6 <sup>n)</sup>	1,030	3 800	5 600	2 320	3 750
LVCD 40 D <sup>n)</sup>	LVCD 40 D-2LS <sup>s)</sup>	LVCD 40 D-2LS/HV6 <sup>n)</sup>	1,966	6 550	9 650	3 350	5 700
LVCD 50 <sup>n)</sup>	LVCD 50-2LS <sup>s)</sup>	LVCD 50 2LS/HV6 <sup>n)</sup>	3,274	8 000	11 200	4 150	6 950

## LVCR PA

Designations	Mass	Basic load ratings		
		dynamic C	at 0,1 m/s	at 4 m/s
LPAR linear plain bearing inside				static <sup>2)</sup> C <sub>0</sub>
–	kg	N		
LVCR 12 PA <sup>n)</sup>	0,107	1 060	26	3 650
LVCR 16 PA <sup>n)</sup>	0,160	1 680	43	5 850
LVCR 20 PA <sup>n)</sup>	0,298	2 700	68	9 500
LVCR 25 PA <sup>n)</sup>	0,623	4 400	110	15 300
LVCR 30 PA <sup>n)</sup>	0,950	6 000	150	20 800
LVCR 40 PA <sup>n)</sup>	1,830	8 650	216	30 000
LVCR 50 PA <sup>n)</sup>	3,144	12 700	320	45 000
LVCR 60 PA <sup>n)</sup>	5,660	19 300	480	67 000
LVCR 80 PA <sup>n)</sup>	12,720	33 500	830	116 000

Items without letter footnote are usually available from stock.

<sup>n)</sup> Delivery time on request

<sup>s)</sup> Delivery time usually 10 days for max. quantity of 4; larger quantities on request

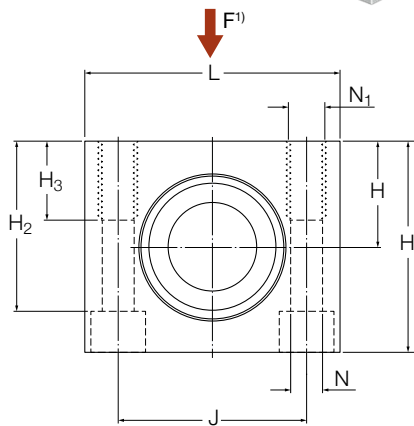
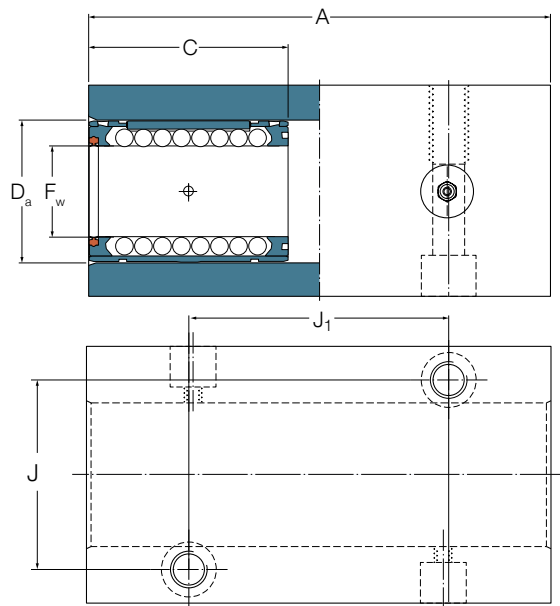
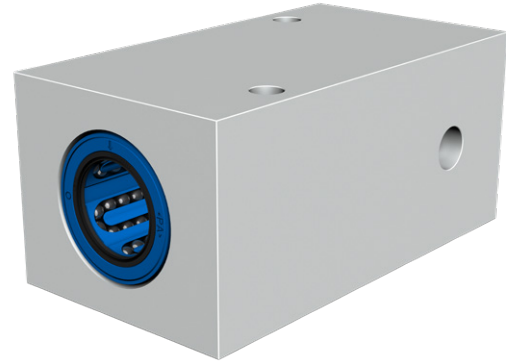
<sup>1)</sup> Basic load ratings are valid for bearing steel and stainless steel variants, but they must be reduced if stainless steel shafts are used

<sup>2)</sup> Valid if the loads onto the housing are exclusively in direction of red arrow. See dimensional drawing on left page

### 3.4.9 Standard tandem units - LTCR/LTCD

- LTCR with rigid LBCR bearing
  - LTCD with self-aligning LBCD bearing
  - LTCR PA with LPAR linear plain bearing
- Closed design in sizes from 12 mm to 50 mm
  - Aluminium housing with 2 mounted bearings
  - Available as sealed or shielded variant
  - Available as bearing steel (standard) or stainless steel variant
  - Factory pre-lubricated with SKF LGEP 2 grease, ready for use
  - Equipped with grease fitting
  - Able to bolt from top or bottom side

Please find suitable shaft blocks or shaft supports in **chapter3.6** and shafts in **chapter3.7**



*Pictured is LTCD 30 D-2LS <sup>2)</sup>*

*Picture shows LTCD D with double lip seals on the outside <sup>2)</sup>*

Dimensions												
F <sub>w</sub>	A	C	D <sub>a</sub>	H ±0,01	H <sub>1</sub>	H <sub>2</sub>	H <sub>3</sub>	J	J <sub>1</sub>	L	N <sup>3)</sup>	N <sub>1</sub>
mm												-
12	76	32	22	18	35	27	13	30	40	42	5,3	M6
16	84	36	26	22	41,5	33,0	13	36	45	50	5,3	M6
20	104	45	32	25	49,5	39,5	18	45	55	60	6,4	M8
25	130	58	40	30	59,5	47	22	54	70	74	8,4	M10
30	152	68	47	35	69,5	55	26	62	85	84	10,5	M12
40	176	80	62	45	89,5	71	34	80	100	108	13	M16
50	224	100	75	50	99,5	81	34	100	125	130	13	M16

<sup>1)</sup> Direction for max. load ratings

<sup>2)</sup> Picture with non D-series bearing or plain bearing differs

<sup>3)</sup> For 2 cylinder head screws with internal hexagon according to ISO 4762

## LTCR

Designations			Mass kg	Basic load ratings <sup>1)</sup>			
LBCR bearing inside with shields	with double lip seal	Stainless steel variant of LBCR bearing inside with double lip seal		dynamic C min N	max	static C <sub>0</sub> min	max
–							
LTCD 12 D <sup>n)</sup>	LTCD 12 D-2LS <sup>s)</sup>	LTCD 12 D-2LS/HV6 <sup>n)</sup>	0,248	1 500	2240	1 400	2 240
LTCD 16 D <sup>n)</sup>	LTCD 16 D-2LS <sup>s)</sup>	LTCD 16 D-2LS/HV6 <sup>n)</sup>	0,387	1 760	2 600	1 600	2 600
LTCD 20 D <sup>n)</sup>	LTCD 20 D-2LS <sup>s)</sup>	LTCD 20 D-2LS/HV6 <sup>n)</sup>	0,696	3 550	5 300	3 250	5 300
LTCD 25 D <sup>n)</sup>	LTCD 25 D-2LS <sup>s)</sup>	LTCD 25 D-2LS/HV6 <sup>n)</sup>	1,282	5 000	7 350	4 750	7 650
LTCD 30 D <sup>n)</sup>	LTCD 30 D-2LS <sup>s)</sup>	LTCD 30 D-2LS/HV6 <sup>n)</sup>	1,942	7 800	11 600	7 100	11 400
LTCD 40 D <sup>n)</sup>	LTCD 40 D-2LS <sup>s)</sup>	LTCD 40 D-2LS/HV6 <sup>n)</sup>	3,683	12 500	18 300	10 200	16 600
LTCD 50 <sup>n)</sup>	LTCD 50-2LS <sup>s)</sup>	LTCD 50-2LS/HV6 <sup>n)</sup>	5,970	15 600	21 600	14 300	24 500

## LTCD

Designations			Mass kg	Basic load ratings <sup>1)</sup>			
Self-aligning LBCD bearing inside with shields	with double lip seal	Stainless steel variant of self-aligning LBCD bearing inside with double lip seal		dynamic C min N	max	static C <sub>0</sub> min	max
–							
LTCD 12 D <sup>n)</sup>	LTCD 12 D-2LS <sup>s)</sup>	LTCD 12 D-2LS/HV6 <sup>n)</sup>	0,248	1 290	2 000	1 140	1 860
LTCD 16 D <sup>n)</sup>	LTCD 16 D-2LS <sup>s)</sup>	LTCD 16 D-2LS/HV6 <sup>n)</sup>	0,385	1 530	2 280	1 320	2 120
LTCD 20 D <sup>n)</sup>	LTCD 20 D-2LS <sup>s)</sup>	LTCD 20 D-2LS/HV6 <sup>n)</sup>	0,694	2 800	4 150	2 240	3 600
LTCD 25 D <sup>n)</sup>	LTCD 25 D-2LS <sup>s)</sup>	LTCD 25 D-2LS/HV6 <sup>n)</sup>	1,278	4 250	6 200	2 850	4 650
LTCD 30 D <sup>n)</sup>	LTCD 30 D-2LS <sup>s)</sup>	LTCD 30 D-2LS/HV6 <sup>n)</sup>	1,938	6 200	9 150	4 650	7 500
LTCD 40 D <sup>n)</sup>	LTCD 40 D-2LS <sup>s)</sup>	LTCD 40 D-2LS/HV6 <sup>n)</sup>	3,669	10 600	15 600	6 700	11 400
LTCD 50 <sup>n)</sup>	LTCD 50-2LS <sup>s)</sup>	LTCD 50-2LS/HV6 <sup>n)</sup>	5,930	12 900	18 300	8 300	14 000

## LTCD PA

Designations	Mass kg	Basic load ratings		static <sup>2)</sup> C <sub>0</sub>
		dynamic C at 0,1 m/s N	at 4 m/s	
–				
LTCD 12 PA <sup>n)</sup>	0,228	2 120	52	7 300
LTCD 16 PA <sup>n)</sup>	0,365	3 360	86	11 700
LTCD 20 PA <sup>n)</sup>	0,640	5 400	136	19 000
LTCD 25 PA <sup>n)</sup>	1,176	8 800	220	30 600
LTCD 30 PA <sup>n)</sup>	1,778	12 000	300	41 600
LTCD 40 PA <sup>n)</sup>	3,397	17 300	432	60 000
LTCD 50 PA <sup>n)</sup>	5,670	25 400	640	90 000

<sup>n)</sup> Delivery time on request

<sup>s)</sup> Delivery time usually 10 days for max. quantity of 4; larger quantities on request

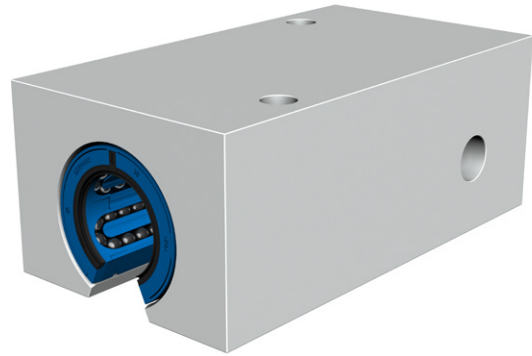
<sup>1)</sup> Basic load ratings are valid for bearing steel and stainless steel variants, but they must be reduced if stainless steel shafts are used

<sup>2)</sup> Valid if the loads onto the housing are exclusively in direction of red arrow. See dimensional drawing on left page

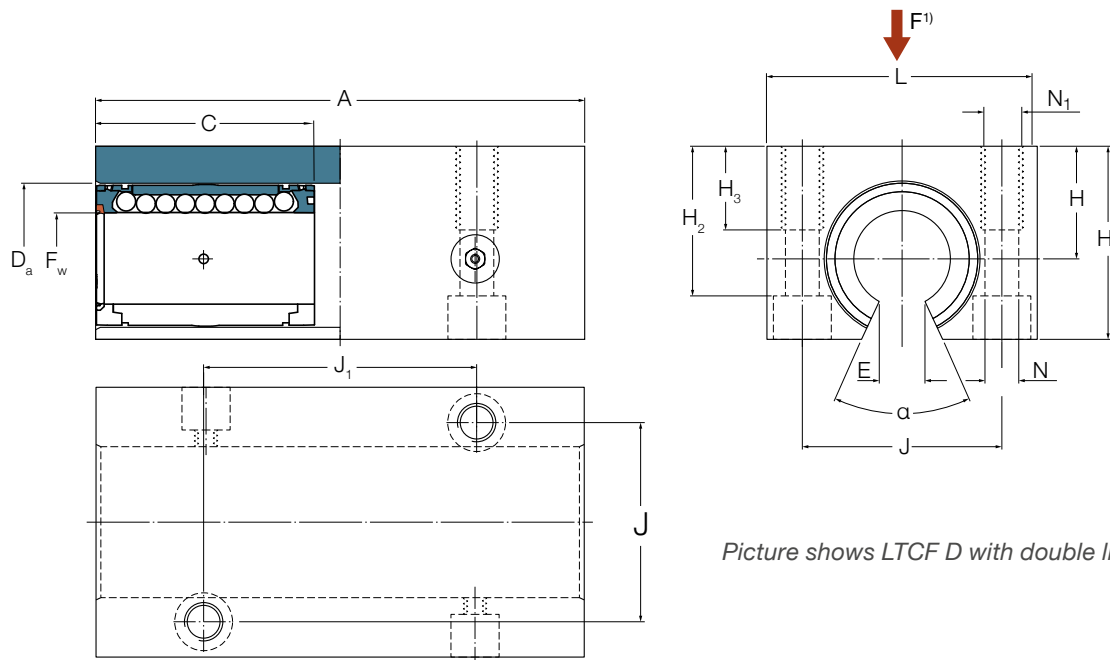
### 3.4.10 Standard tandem units - LTCT/LTCF

- LTCT with rigid LBCT bearing
  - LTCF with self-aligning LBCF bearing
  - LTCT PA with LPAT linear plain bearing
- Open design in sizes from 12 mm to 50 mm
  - Aluminium housing with 2 mounted bearings
  - Available as sealed or shielded variant
  - Available as bearing steel (standard) or stainless steel variant
  - Factory pre-lubricated with SKF LGEP 2 grease, ready for use
  - Equipped with grease fitting
  - Able to bolt from top or bottom side

Please find suitable shaft blocks or shaft supports in **chapter3.6** and shafts in **chapter3.7**



Pictured is LTCF 30 D-2LS <sup>2)</sup>



Picture shows LTCF D with double lip seals on the outside <sup>2)</sup>

Dimensions														
$F_w$	A	C	$D_a$	H $\pm 0,01$	$H_1$	$H_2$	$H_3$	J	$J_1$	L	$N^{3)}$	$N_1$	$E^{4)}$	$\alpha$
mm												-	mm	Deg.
12	76	32	22	18	29	23,5	13	30	40	42	5,3	M6	7,6	78
16	84	36	26	22	35	28	13	36	45	50	5,3	M6	10,4	78
20	104	45	32	25	42	33,5	18	45	55	60	6,4	M8	10,8	60
25	130	58	40	30	51	40	22	54	70	74	8,4	M10	13,2	60
30	152	68	47	35	60	46,5	26	62	85	84	10,5	M12	14,2	50
40	176	80	62	45	77	61	34	80	100	108	13	M16	18,7	50
50	224	100	75	50	88	72	34	100	125	130	13	M16	23,6	50

<sup>1)</sup> Direction for max. load ratings

<sup>2)</sup> Picture with non D-series bearing or plain bearing differs

<sup>3)</sup> For cylinder head screws with internal hexagon according to ISO 4762

<sup>4)</sup> Minimum sector width at diameter  $F_w$



## LTCT

Designations			Mass kg	Basic load ratings <sup>1)</sup>			
LBCT bearing inside with shields	with double lip seal	Stainless steel variant of LBCT bearing inside with double lip seal		dynamic C min N	max	static C <sub>0</sub> min	max
–							
LTCT 12 D <sup>n)</sup>	LTCT 12 D-2LS <sup>n)</sup>	LTCT 12 D-2LS/HV6 <sup>n)</sup>	0,189	1 120	2 000	1 020	2 040
LTCT 16 D <sup>n)</sup>	LTCT 16 D-2LS <sup>n)</sup>	LTCT 16 D-2LS/HV6 <sup>n)</sup>	0,296	1 250	2 450	1 180	2 750
LTCT 20 D <sup>n)</sup>	LTCT 20 D-2LS <sup>n)</sup>	LTCT 20 D-2LS/HV6 <sup>n)</sup>	0,543	3 000	5 200	2 700	5 400
LTCT 25 D <sup>n)</sup>	LTCT 25 D-2LS <sup>n)</sup>	LTCT 25 D-2LS/HV6 <sup>n)</sup>	1,004	4 400	7 500	4 000	8 000
LTCT 30 D <sup>n)</sup>	LTCT 30 D-2LS <sup>n)</sup>	LTCT 30 D-2LS/HV6 <sup>n)</sup>	1,548	6 700	11 600	6 000	12 000
LTCT 40 D <sup>u)</sup>	LTCT 40 D-2LS <sup>u)</sup>	LTCT 40 D-2LS/HV6 <sup>u)</sup>	2,918	10 400	18 000	8 500	17 000
LTCT 50 <sup>n)</sup>	LTCT 50-2LS <sup>n)</sup>	LTCT 50-2LS/HV6 <sup>n)</sup>	4,880	9 500	21 600	10 600	24 500

## LTCF

Designations			Mass kg	Basic load ratings <sup>1)</sup>			
Self-aligning LBCF bearing inside with shields	with double lip seal	Stainless steel variant of self-aligning LBCF bearing inside with double lip seal		dynamic C min N	max	static C <sub>0</sub> min	max
–							
LTCF 12 D <sup>n)</sup>	LTCF 12 D-2LS <sup>s)</sup>	LTCF 12 D-2LS/HV6 <sup>n)</sup>	0,189	980	1 760	830	1 700
LTCF 16 D <sup>n)</sup>	LTCF 16 D-2LS <sup>s)</sup>	LTCF 16 D-2LS/HV6 <sup>n)</sup>	0,296	1 080	2 160	965	2 240
LTCF 20 D <sup>n)</sup>	LTCF 20 D-2LS <sup>s)</sup>	LTCF 20 D-2LS/HV6 <sup>n)</sup>	0,541	2 360	4 050	1 830	3 660
LTCF 25 D <sup>n)</sup>	LTCF 25 D-2LS <sup>s)</sup>	LTCF 25 D-2LS/HV6 <sup>n)</sup>	1,000	3 750	6 300	2 450	4 900
LTCF 30 D <sup>n)</sup>	LTCF 30 D-2LS <sup>s)</sup>	LTCF 30 D-2LS/HV6 <sup>n)</sup>	1,544	5 300	9 300	3 900	7 800
LTCF 40 D <sup>u)</sup>	LTCF 40 D-2LS <sup>u)</sup>	LTCF 40 D-2LS/HV6 <sup>u)</sup>	2,910	9 000	15 300	6 000	11 800
LTCF 50 <sup>n)</sup>	LTCF 50-2LS <sup>s)</sup>	LTCF 50-2LS/HV6 <sup>n)</sup>	4,840	8 000	18 300	6 000	14 000

## LTCT PA

Designations	Mass kg	Basic load ratings		static <sup>2)</sup> C <sub>0</sub>
		dynamic C at 0,1 m/s N	at 4 m/s	
LPAT linear plain bearing inside				
–				
LTCT 12 PA <sup>n)</sup>	0,173	2 120	52	7 300
LTCT 16 PA <sup>n)</sup>	0,280	3 360	86	117 00
LTCT 20 PA <sup>n)</sup>	0,500	5 400	136	19 000
LTCT 25 PA <sup>n)</sup>	0,916	8 800	220	30 600
LTCT 30 PA <sup>n)</sup>	1,412	12 000	300	41 600
LTCT 40 PA <sup>n)</sup>	2,684	17 300	432	60 000
LTCT 50 PA <sup>n)</sup>	4,640	25 400	640	90 000

<sup>n)</sup> Delivery time on request

<sup>s)</sup> Delivery time usually 10 days for max. quantity of 4; larger quantities on request

<sup>u)</sup> Size 40 under development; A-design unit is available until replacement

<sup>1)</sup> Basic load ratings are valid for bearing steel and stainless steel variants, but they must be reduced if stainless steel shafts are used

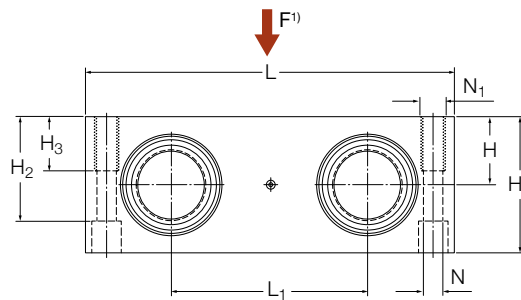
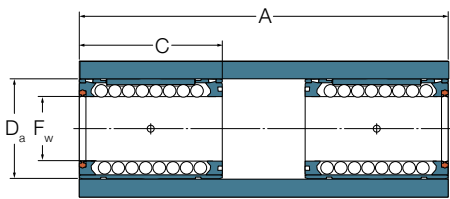
<sup>2)</sup> Valid if the loads onto the housing are exclusively in direction of red arrow. See dimensional drawing on left page

### 3.4.11 Standard quadro units - LQCR/LQCD

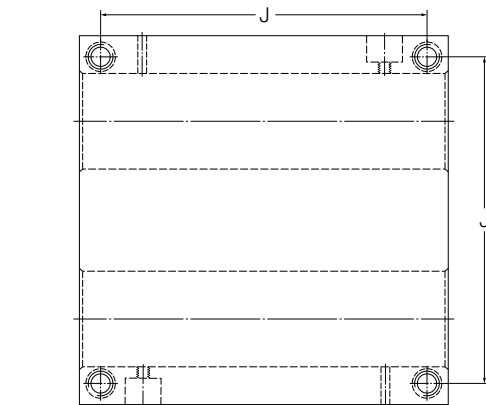
- LQCR with rigid LBCR bearing
  - LQCD with self-aligning LBCD bearing
  - LQCR PA with LPAR linear plain bearing
- Closed design in sizes from 8 mm to 50 mm
  - Aluminium housing with 4 mounted bearings
  - Available as sealed or shielded variant
  - Available as bearing steel (standard) or stainless steel variant
  - Factory pre-lubricated with SKF LGEP 2 grease, ready for use
  - Equipped with grease fitting
  - Able to bolt from top or bottom side



Please find suitable shaft blocks or shaft supports in **chapter3.6** and shafts in **chapter3.7**



*Pictured is LQCD 30 D-2LS <sup>2)</sup>*



*Picture shows LQCD D with double lip seals on the outside <sup>2)</sup>*

**Dimensions**

$F_w$	A	C	$D_a$	$H_{\pm 0,01}$	$H_1$	$H_2$	$H_3$	J	L	$L_1$	$N^{3)}$	$N_1$
mm												-
8	65	25	16	11,5	23	17,5	11	55	65	32	4,3	M5
12	85	32	22	16	32	25	13	73	85	42	5,3	M6
16	100	36	26	18	36	29	13	88	100	54	5,3	M6
20	130	45	32	23	46	37,5	18	115	130	72	6,6	M8
25	160	58	40	28	56	45	22	140	160	88	8,4	M10
30	180	68	47	32	64	50,5	26	158	180	96	10,5	M12
40	230	80	62	40	80	64	34	202	230	122	13,5	M16
50	280	100	75	48	96	80	34	250	280	152	13,5	M16

<sup>1)</sup> Direction for max. load ratings

<sup>2)</sup> Picture with non D-series bearing or plain bearing differs

<sup>3)</sup> For 4 cylinder head screws with internal hexagon according to ISO 4762

## LQCR

Designations			Mass	Basic load ratings <sup>1)</sup>			
LQCR bearing inside with shields	with double lip seal	Stainless steel variant of LQCR bearing with double lip seal		dynamic C	max	static C <sub>0</sub>	max
–			kg	min N		min	
LQCR 8 <sup>2) n)</sup>	LQCR 8-2LS <sup>2) n)</sup>	LQCR 8-2LS/HV6 <sup>2) n)</sup>	0,219	1 290	1 500	1 430	2 000
LQCR 12 D <sup>n)</sup>	LQCR 12 D-2LS <sup>n)</sup>	LQCR 12 D-2LS/HV6 <sup>n)</sup>	0,513	2 450	3 600	2 800	4 500
LQCR 16 D <sup>n)</sup>	LQCR 16 D-2LS <sup>n)</sup>	LQCR 16 D-2LS/HV6 <sup>n)</sup>	0,768	2 850	4 250	3 200	5 200
LQCR 20 D <sup>n)</sup>	LQCR 20 D-2LS <sup>n)</sup>	LQCR 20 D-2LS/HV6 <sup>n)</sup>	1,731	5 850	8 650	6 550	10 600
LQCR 25 D <sup>n)</sup>	LQCR 25 D-2LS <sup>n)</sup>	LQCR 25 D-2LS/HV6 <sup>n)</sup>	3,112	8 150	12 000	9 500	15 300
LQCR 30 D <sup>n)</sup>	LQCR 30 D-2LS <sup>n)</sup>	LQCR 30 D-2LS/HV6 <sup>n)</sup>	4,419	12 700	18 600	14 300	22 800
LQCR 40 D <sup>n)</sup>	LQCR 40 D-2LS <sup>n)</sup>	LQCR 40 D-2LS/HV6 <sup>n)</sup>	8,642	20 000	30 000	20 400	33 500
LQCR 50 <sup>n)</sup>	LQCR 50-2LS <sup>n)</sup>	LQCR 50-2LS/HV6 <sup>n)</sup>	15,090	25 500	35 500	29 000	49 000

## LQCD

Designations			Mass	Basic load ratings <sup>1)</sup>			
Self-aligning LQCD bearing inside with shields	with double lip seal	Stainless steel variant of self-aligning LQCD bearing inside with double lip seal		dynamic C	max	static C <sub>0</sub>	max
–			kg	min N		min	
LQCD 12 D <sup>n)</sup>	LQCD 12 D-2LS	LQCD 12 D-2LS/HV6 <sup>n)</sup>	0,513	2 120	3 200	2 280	3 750
LQCD 16 D <sup>n)</sup>	LQCD 16 D-2LS	LQCD 16 D-2LS/HV6 <sup>n)</sup>	0,764	2 500	3 650	2 600	4 250
LQCD 20 D <sup>n)</sup>	LQCD 20 D-2LS	LQCD 20 D-2LS/HV6 <sup>n)</sup>	1,727	4 550	6 700	4 500	7 200
LQCD 25 D <sup>n)</sup>	LQCD 25 D-2LS	LQCD 25 D-2LS/HV6 <sup>n)</sup>	3,104	6 800	10 000	5 700	9 300
LQCD 30 D <sup>n)</sup>	LQCD 30 D-2LS	LQCD 30 D-2LS/HV6 <sup>n)</sup>	4,411	10 000	14 600	9 300	15 000
LQCD 40 D <sup>n)</sup>	LQCD 40 D-2LS	LQCD 40 D-2LS/HV6 <sup>n)</sup>	8,614	17 300	25 500	13 400	22 800
LQCD 50 <sup>n)</sup>	LQCD 50-2LS	LQCD 50-2LS/HV6 <sup>n)</sup>	15,010	2 1200	30 000	16 600	28 000

## LQCR PA

Designations	Mass	Basic load ratings		static <sup>3)</sup> C <sub>0</sub>
LQCR linear plain bearing inside		dynamic C		
–	kg	at 0,1 m/s N	at 4 m/s	
LQCR 8 PA <sup>n)</sup>	0,203	2 280	56	8 000
LQCR 12 PA <sup>n)</sup>	0,473	4 240	104	14 600
LQCR 16 PA <sup>n)</sup>	0,724	6 720	172	23 400
LQCR 20 PA <sup>n)</sup>	1,619	10 800	272	38 000
LQCR 25 PA <sup>n)</sup>	2,900	17 600	440	61 200
LQCR 30 PA <sup>n)</sup>	4,091	24 000	600	83 200
LQCR 40 PA <sup>n)</sup>	8,070	34 600	864	120 000
LQCR 50 PA <sup>n)</sup>	14,490	50 800	1 280	180 000

Items without letter footnote are usually available from stock.

<sup>n)</sup> Delivery time on request

<sup>1)</sup> Delivery time usually 10 days for max. quantity of 4; larger quantities on request

<sup>1)</sup> Basic load ratings are valid for bearing steel and stainless steel variants, but they must be reduced if stainless steel shafts are used

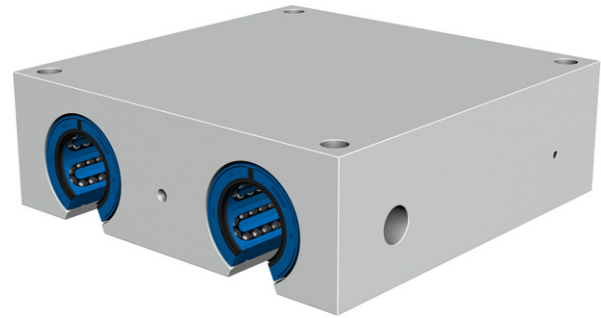
<sup>2)</sup> Units in size 8 mm are without relubrication

<sup>3)</sup> Valid if the loads onto the housing are exclusively in direction of red arrow. See dimensional drawing on left page

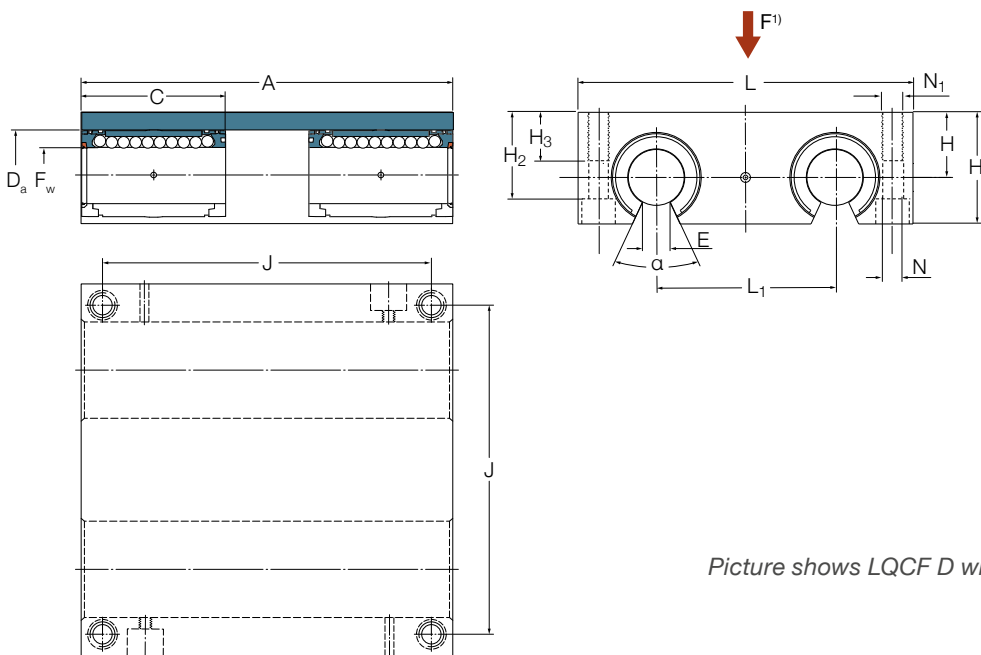
### 3.4.12 Standard quadro units - LQCT/LQCF

- LQCT with rigid LBCT bearing
  - LQCF with self-aligning LBCF bearing
  - LQCT PA with LPAT linear plain bearing
- Open design in sizes from 12 mm to 50 mm
  - Aluminium housing with 4 mounted bearings
  - Available as sealed or shielded variant
  - Available as bearing steel (standard) or stainless steel variant
  - Factory pre-lubricated with SKF LGEP 2 grease, ready for use
  - Equipped with grease fitting
  - Able to bolt from top or bottom side

Please find suitable shaft blocks or shaft supports in **chapter3.6** and shafts in **chapter3.7**



*Pictured is LQCF 30 D-2LS <sup>2)</sup>*



*Picture shows LQCF D with double lip seals on the outside <sup>2)</sup>*

**Dimensions**

$F_w$	A	C	$D_a$	$H$ $\pm 0,01$	$H_1$	$H_2$	$H_3$	J	L	$L_1$	$N$ <sup>3)</sup>	$N_1$	$E$ <sup>4)</sup>	$\alpha$
mm												-	mm	Deg.
12	85	32	22	18	30	23,4	13	73	85	42	5,3	M6	7,6	78
16	100	36	26	22	35	28,4	13	88	100	54	5,3	M6	10,4	78
20	130	45	32	25	42	33,5	18	115	130	72	6,6	M8	10,8	60
25	160	58	40	30	51	40	22	140	160	88	8,4	M10	13,2	60
30	180	68	47	35	60	46,5	26	158	180	96	10,5	M12	14,2	50
40	230	80	62	45	77	61	34	202	230	122	13,5	M16	18,7	50
50	280	100	75	55	93	77	34	250	280	152	13,5	M16	23,6	50

<sup>1)</sup> Direction for max. load ratings

<sup>2)</sup> Picture with non D-series bearing or plain bearing differs

<sup>3)</sup> For cylinder head screws with internal hexagon according to ISO 4762

<sup>4)</sup> Minimum sector width at diameter  $F_w$

## LQCT

Designations			Mass kg	Basic load ratings <sup>1)</sup>			
LBCT bearing inside with shields	with double lip seal	Stainless steel variant of LBCT bearing inside with double lip seal		dynamic C min N	max	static C <sub>0</sub> min	max
–							
LQCT 12 D <sup>n)</sup>	LQCT 12 D-2LS <sup>n)</sup>	LQCT 12 D-2LS/HV6 <sup>n)</sup>	0,444	1 830	3 200	2 040	4 050
LQCT 16 D <sup>n)</sup>	LQCT 16 D-2LS <sup>n)</sup>	LQCT 16 D-2LS/HV6 <sup>n)</sup>	0,710	2 000	4 000	2 360	5 500
LQCT 20 D <sup>n)</sup>	LQCT 20 D-2LS <sup>n)</sup>	LQCT 20 D-2LS/HV6 <sup>n)</sup>	1,458	4 900	8 500	5 400	10 800
LQCT 25 D <sup>n)</sup>	LQCT 25 D-2LS <sup>n)</sup>	LQCT 25 D-2LS/HV6 <sup>n)</sup>	2,654	7 100	12 200	8 000	16 000
LQCT 30 D <sup>n)</sup>	LQCT 30 D-2LS <sup>n)</sup>	LQCT 30 D-2LS/HV6 <sup>n)</sup>	3,918	11 000	19 000	12 000	24 000
LQCT 40 D <sup>u)</sup>	LQCT 40 D-2LS <sup>u)</sup>	LQCT 40 D-2LS/HV6 <sup>u)</sup>	8,078	17 000	29 000	17 000	34 000
LQCT 50 <sup>n)</sup>	LQCT 50-2LS <sup>n)</sup>	LQCT 50-2LS/HV6 <sup>n)</sup>	14,060	15 300	35 500	21 200	49 000

## LQCF

Designations			Mass kg	Basic load ratings <sup>1)</sup>			
Self-aligning LBCF bearing inside with shields	with double lip seal	Stainless steel variant of self-aligning LBCF bearing inside with double lip seal		dynamic C min N	max	static C <sub>0</sub> min	max
–							
LQCF 12 D <sup>n)</sup>	LQCF 12 D-2LS <sup>s)</sup>	LQCF 12 D-2LS/HV6 <sup>n)</sup>	0,444	1 600	2 850	1 660	3 400
LQCF 16 D <sup>n)</sup>	LQCF 16 D-2LS <sup>s)</sup>	LQCF 16 D-2LS/HV6 <sup>n)</sup>	0,71	1 760	3 450	1 930	4 500
LQCF 20 D <sup>n)</sup>	LQCF 20 D-2LS <sup>s)</sup>	LQCF 20 D-2LS/HV6 <sup>n)</sup>	1,454	3 900	6 550	3 650	7 350
LQCF 25 D <sup>n)</sup>	LQCF 25 D-2LS <sup>s)</sup>	LQCF 25 D-2LS/HV6 <sup>n)</sup>	2,646	6 000	10 200	4 900	9 800
LQCF 30 D <sup>n)</sup>	LQCF 30 D-2LS <sup>s)</sup>	LQCF 30 D-2LS/HV6 <sup>n)</sup>	3,91	8 650	15 000	7 800	15 600
LQCF 40 D <sup>u)</sup>	LQCF 40 D-2LS <sup>u)</sup>	LQCF 40 D-2LS/HV6 <sup>u)</sup>	8,062	14 600	25 000	12 000	23 600
LQCF 50 <sup>n)</sup>	LQCF 50-2LS <sup>s)</sup>	LQCF 50-2LS/HV6 <sup>n)</sup>	13,98	12 900	30 000	12 000	28 000

## LQCT PA

Designations	Mass kg	Basic load ratings		static <sup>2)</sup> C <sub>0</sub>
		dynamic C at 0,1 m/s N	at 4 m/s	
LPAT linear plain bearing inside				
–				
LQCT 12 PA <sup>n)</sup>	0,412	4 240	104	14 600
LQCT 16 PA <sup>n)</sup>	0,678	6 720	172	23 400
LQCT 20 PA <sup>n)</sup>	1,366	10 800	272	38 000
LQCT 25 PA <sup>n)</sup>	2,478	17 600	440	61 200
LQCT 30 PA <sup>n)</sup>	3,646	24 000	600	83 200
LQCT 40 PA <sup>n)</sup>	7,610	34 600	864	120 000
LQCT 50 PA <sup>n)</sup>	13,580	50 800	1 280	180 000

<sup>n)</sup> Delivery time on request<sup>s)</sup> Delivery time usually 10 days for max. quantity of 4; larger quantities on request<sup>u)</sup> 40 under development; A-design unit is available until replacement<sup>1)</sup> Basic load ratings are valid for bearing steel and stainless steel variant, but they must be reduced if stainless steel shafts are used<sup>2)</sup> Valid if the loads onto the housing are exclusively in direction of red arrow. See dimensional drawing on left page

## 3.5 Standard housings

Linear ball bearings must be mounted into housings for proper usage. This combination is called linear bearing unit and the previous chapters show the range of units available. For flexible use, Ewellix offers single lightweight aluminium housings as component. The housings are ready machined to be equipped with Ewellix standard bearings. The high

quality design has a defined reference side for linear alignment. It offers flexible installation and bolting possibilities depending on the application. The axial and radial bearing fixation is made for standard ISO bearings. With each housing, Ewellix delivers a grease fitting for the bearing fixation. Three types of housing variants are available.

### LHCR



Lightweight linear bearing housing in closed design. Available in sizes from 8 mm to 80 mm for standard bearings. Easy to bolt from top or bottom surface, with a reference side for linear alignment. Made for bearing fixation via grease fitting for lubrication, except in size 8 mm.

### LHCS



Lightweight linear bearing housing in slotted design for adjustable clearance. Available in sizes from 8 mm to 80 mm for standard bearings. Easy to bolt from top or bottom surface, with a reference side for linear alignment. Made for bearing fixation via grease fitting for lubrication, except in size 8 mm.

### LHCT



Lightweight linear bearing housing in open design. Available in sizes from 12 mm to 80 mm for standard bearings. Easy to bolt from top or bottom surface, with a reference side for linear alignment. Made for bearing fixation via grease fitting for lubrication.

### 3.5.1 Standard housings - LHCR/LHCS

- LHCR in closed design
- LHCS in slotted design for adjustable clearance

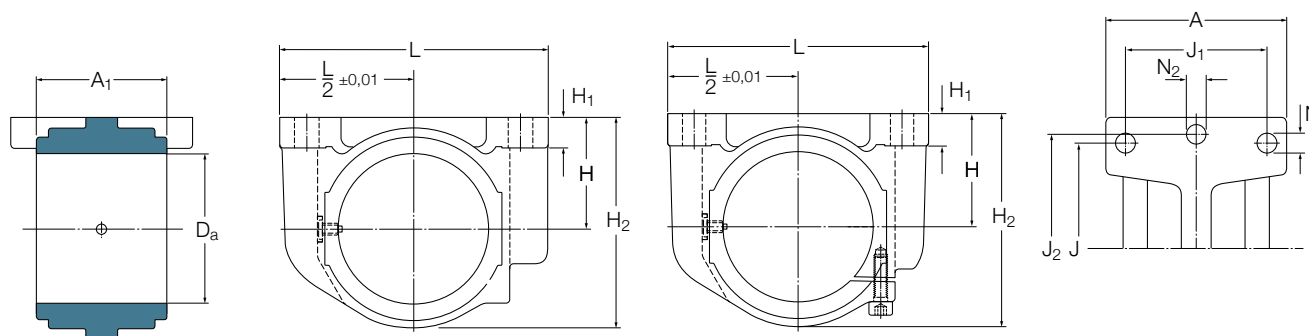
- Closed and slotted design in sizes from 8 mm to 80 mm
- Lightweight die-cast aluminium housing
- Able to bolt from top or bottom side
- With reference side for linear alignment
- Supplied with grease fitting for lubrication and axial bearing fixation



Pictured is LHCR 30

Pictured is LHCS 30

Please find suitable shaft blocks or shaft supports in **chapter3.6** and shafts in **chapter3.7**



#### Dimensions

$D_a$ Tolerance J6 mm	A	$A_1$	H $\pm 0,01$	$H_1$	$H_2$	J	$J_1$	$J_2$	$L$ <sup>1)</sup>	$N$ <sup>2)</sup>	$N_2$ <sup>2)</sup>
16	27	14	15	5,5	28	25	20	35	45	3,2	5,3
22	31	20	18	6	34,5	32	23	42	52	4,3	5,3
26	34,5	22	22	7	40,5	40	26	46	56	4,3	5,3
32	41	28	25	8	48	45	32	58	70	4,3	6,4
40	52	40	30	10	58	60	40	68	80	5,3	6,4
47	59	48	35	10	67	68	45	76	88	6,4	6,4
62	74	56	45	12	85	86	58	94	108	8,4	8,4
75	66	72	50	14	99	108	50	116	135	8,4	10,5
90	84	95	60	18	118	132	65	138	160	10,5	13
120	113	125	80	22	158	170	90	180	205	13	13

Designations	Designations slotted	Mass kg	Grease fitting	Screw ISO 4762 (only LHCS)
-			-	
LHCR 8 <sup>3)</sup>	LHCS 8 <sup>3)</sup>	0,018	-	M3
LHCR 12 <sup>3)</sup>	LHCS 12 <sup>3)</sup>	0,038	VN-LHC 20	M3
LHCR 16 <sup>3)</sup>	LHCS 16 <sup>3)</sup>	0,05	VN-LHC 20	M3
LHCR 20 <sup>3)</sup>	LHCS 20 <sup>3)</sup>	0,1	VN-LHC 20	M4
LHCR 25 <sup>3)</sup>	LHCS 25 <sup>3)</sup>	0,2	VN-LHC 40	M5
LHCR 30 <sup>3)</sup>	LHCS 30 <sup>3)</sup>	0,28	VN-LHC 40	M6
LHCR 40 <sup>3)</sup>	LHCS 40 <sup>3)</sup>	0,47	VN-LHC 40	M6
LHCR 50 <sup>3)</sup>	LHCS 50 <sup>3)</sup>	0,76	VN-LHC 50	M8
LHCR 60 <sup>3)</sup>	LHCS 60 <sup>3)</sup>	1,35	VN-LHC 80	M10
LHCR 80 <sup>3)</sup>	LHCS 80 <sup>3)</sup>	3,25	VN-LHC 80	M12

<sup>1)</sup> For housings from size 50 to 80: Tolerance  $L/2 \pm 0,02$

<sup>2)</sup> For cylinder head screws with internal hexagon according to ISO 4762

<sup>3)</sup> Delivery time usually 10 days for max. quantity of 4; larger quantities on request

### 3.5.2 Standard housings - LHCT

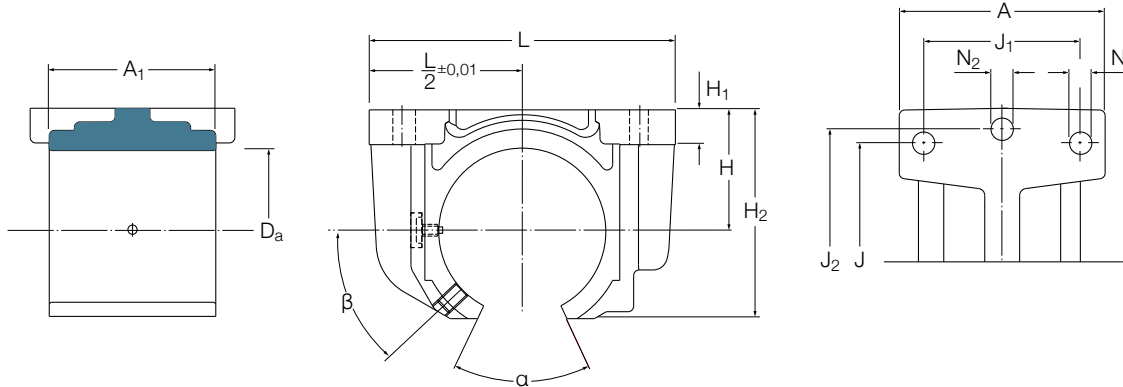
- LHCT in open design

- Open design in sizes from 12 mm to 80 mm
- Lightweight die-cast aluminium housing
- Able to bolt from top or bottom side
- With reference side for linear alignment
- Supplied with grease fitting for lubrication and axial bearing fixation
- Possibility of adjustable clearance with Ewellix bearings



Please find suitable shaft blocks or shaft supports in **chapter3.6** and shafts in **chapter3.7**

Pictured is LHCT 30



**Dimensions**

$D_a$ Tolerance J6 mm	A	$A_1$	H $\pm 0,01$	$H_1$	$H_2$	J	$J_1$	$J_2$	$L^{1)}$	$N^{2)}$	$N_2^{2)}$	$\alpha$	$\beta$
												Deg.	
22	31	20	18	6	28	32	23	42	52	4,3	5,3	78	29
26	34,5	22	22	7	35	40	26	46	56	4,3	5,3	78	27,6
32	41	28	25	8	42	45	32	58	70	4,3	6,4	60	42
40	52	40	30	10	51	60	40	68	80	5,3	6,4	60	43
47	59	48	35	10	60	68	45	76	88	6,4	6,4	50	43,6
62	74	56	45	12	77	86	58	94	108	8,4	8,4	50	42,5
75	66	72	50	14	88	108	50	116	135	8,4	10,5	50	30
90	84	95	60	18	105	132	65	138	160	10,5	13,0	54	30
120	113	125	80	22	140	170	90	180	205	13,0	13,0	54	30

Designations	Mass kg	Grease fitting	Grub screw ISO 4026
-		-	
LHCT 12 D <sup>s)3)</sup>	0,034	VN-LHC 20	M3
LHCT 16 D <sup>s)3)</sup>	0,045	VN-LHC 20	M3
LHCT 20 D <sup>s)3)</sup>	0,092	VN-LHC 20	M5
LHCT 25 D <sup>s)3)</sup>	0,18	VN-LHC 40	M5
LHCT 30 D <sup>s)3)</sup>	0,25	VN-LHC 40	M5
LHCT 40 D <sup>u)3)</sup>	0,41	VN-LHC 40	M5
LHCT 50 <sup>s)</sup>	0,67	VN-LHC 50	M6
LHCT 60 <sup>s)</sup>	1,18	VN-LHC 80	M8
LHCT 80 <sup>s)</sup>	2,86	VN-LHC 80	M8

<sup>1)</sup> For housings from size 50 to 80: Tolerance  $L/2 \pm 0,02$   
<sup>2)</sup> For cylinder head screws with internal hexagon according to ISO 4762  
<sup>3)</sup> Adjustable clearance only for D-type bearings (example LBCT 16 D-2LS)  
<sup>4)</sup> Delivery time usually 10 days for max. quantity of 4; larger quantities on request  
<sup>u)</sup> Under development, A-series linear ball bearings of that size are available



## 3.6 Shaft blocks and shaft supports

Shaft blocks and supports are standard components to easily build up linear slides. Single shaft blocks are supposed to be used for closed design linear units with flexible shaft distance and length. In standard applications, they fix the end of the shaft to the surface. Tandem blocks

are specifically made for Ewellix quadro units to allow for easy installation. Shaft supports are used for open design linear units and typically support the entire length of the shaft to avoid bending. They are all made out of aluminium based material.

### LSCS



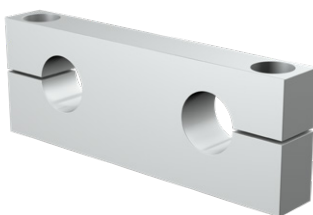
LSCS are lightweight die-cast shaft blocks to be used for compact or standard range units. These blocks securely fasten the shaft position. They can be bolted from top or bottom side and have a reference side for linear alignment. LSCS shaft blocks are available for shaft diameters from 8 mm to 80 mm.

### LSHS/LSNS



LSHS and LSNS shaft blocks are made of aluminium and securely fasten the shaft position. LSHS blocks are designed to be used with Ewellix compact range units, while LSNS blocks are made to fit to the design of the standard range units. They can be bolted from both sides to the mounting surface and are available from 12 mm to 50 mm.

### LEBS/LEAS



LEBS tandem aluminium shaft blocks are made to match with duo or quadro units of the compact range, like LTDR and LQBR. The “A” design is made for moving slides where the tandem blocks are fixed to the surface. They are available from size 12 mm to 50 mm.

LEAS tandem aluminium shaft blocks are designed to match with quadro units of the standard range, like LQCR and LQCD. They are available in both “A” and “B” design, from shaft diameter 8 mm to 50 mm. Compared to the “A” design where the slide is moving and the shafts are fixed, the “B” design allows shaft movement while the quadro unit is fixed.

### LRCB/LRCC



Shaft supports type LRCB/LRCC are suitable for standard range open design units where the shaft support avoids bending of the shaft with heavy loads. Aluminium shaft supports can be used partially, but Ewellix recommends using them over the entire shaft length.

The LRCB design has a predrilled hole pattern for mounting and direct bolting to Ewellix standard shafts ESSC 6, please see **chapter 3.7**, while LRCC has ready machined tolerances prepared for customised mounting holes. Ewellix shaft supports are offered from size 12 mm to 80 mm.

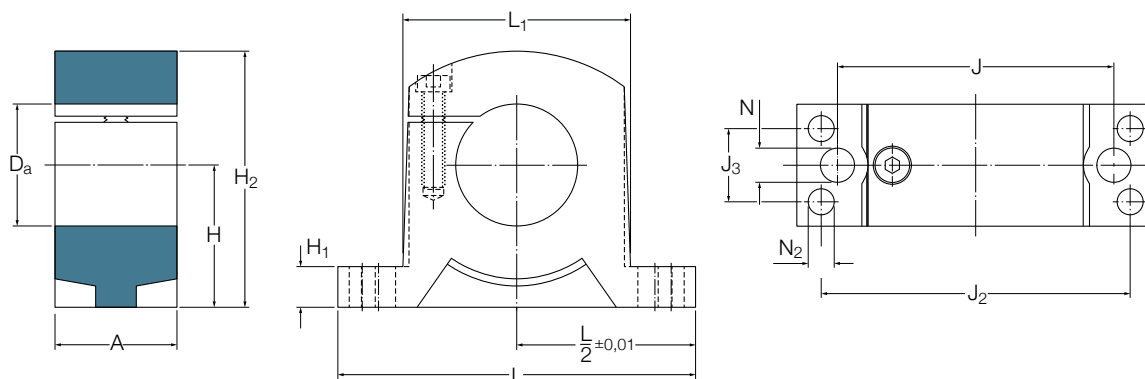
### 3.6.1 Shaft blocks - LSCS

- LSCS for compact or standard range

- Sizes from 8 mm to 80 mm
- Lightweight die-cast aluminium shaft block <sup>3)</sup>
- Shaft clamping screw direction from the top
- Able to bolt from top or bottom side to the surface
- Two different hole patterns for fixation
- Reference surface for linear alignment
- Precise and safe shaft fixation to the surface



*Pictured is LSCS 20*



Dimensions											Designations	Mass		
D <sub>a</sub>	A	H ±0,01	H <sub>1</sub>	H <sub>2</sub>	J	J <sub>2</sub>	J <sub>3</sub>	L <sup>1)</sup>	L <sub>1</sub>	N <sup>2)</sup>	N <sub>2</sub> <sup>2)</sup>	Shaft block	kg	
mm													-	
8	10	15	5,5	25	25	35	5	45	19	4,3	2,7	LSCS 8	0,012	
12	12	20	6	32,5	32	42	6	52	25	5,3	3,2	LSCS 12	0,023	
16	15	20	7	35,5	40	46	7,5	56	31,8	5,3	4,3	LSCS 16	0,034	
20	20	25	8	43,5	45	58	10	70	37	5,3	5,3	LSCS 20	0,065	
25	28	30	10	53	60	68	16	80	48	6,4	6,4	LSCS 25	0,14	
30	30	35	10	63	68	76	18	88	56	8,4	6,4	LSCS 30	0,20	
40	36	45	12	81	86	94	22	108	71	10,5	8,4	LSCS 40	0,47	
50	49	50	14	92,5	108	116	30	135	86	10,5	10,5	LSCS 50	0,68	
60	62	60	18	112	132	138	40	160	105	13	13	LSCS 60	1,29	
80	85	80	22	147,5	170	180	60	205	136	17	15	LSCS 80A	3,15	

Items are usually available from stock.

<sup>1)</sup> For shaft blocks from size 50 to 80: Tolerance L/2 ±0,02

<sup>2)</sup> For cylinder head screws with internal hexagon according to ISO 4762

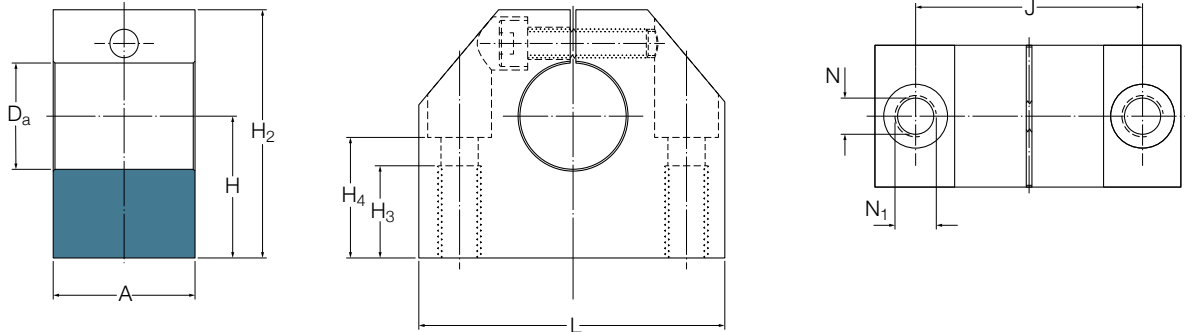
<sup>3)</sup> LSCS 80A is not die-cast and has no forming slopes (see CAD)

## 3.6.2 Compact shaft blocks - LSHS

- Sizes from 12 mm to 50 mm
- Shaft clamping screw direction from the side <sup>3)</sup>
- Able to bolt from top or bottom side to the surface
- Reference surface for linear alignment
- Precise and safe shaft fixation to the surface
- Material: aluminium



*Pictured is LSHS 20*



Dimensions										Designations	Mass	ISO series
D <sub>a</sub>	A	H ±0,01	H <sub>2</sub>	H <sub>3</sub>	H <sub>4</sub>	J	L	N <sup>1)</sup>	N <sub>1</sub>	Shaft block	kg	-
mm												
12	18	19	33	13	16,5	27	40	5,3	M6	LSHS 12	0,05	1
16	20	22	38	13	18	32	45	5,3	M6	LSHS 16	0,07	1
20	24	25	45	18	21	39	53	6,6	M8	LSHS 20	0,11	1
25	28	31	54	22	25	44	62	8,4	M10	LSHS 25	0,17	1
30	30	34	60	22	29	49	67	8,4	M10	LSHS 30	0,22	1
40	40	42	76	26	37	66	87	10,5	M12	LSHS 40	0,47	1
50	50	50	92	34	44	80	103	13,5	M16	LSHS 50	0,82	1

Items are usually available from stock.

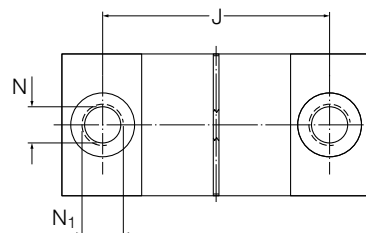
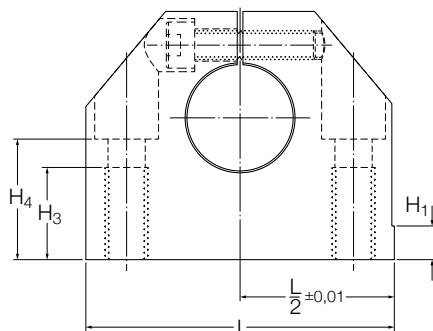
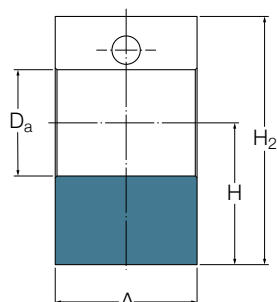
<sup>1)</sup>For cylinder head screws with internal hexagon according to ISO 4762

### 3.6.3 Standard shaft blocks - LSNS

- Sizes from 12 mm to 50 mm
- Shaft clamping screw direction from the side
- Able to bolt from top or bottom side to the surface
- Reference surface for linear alignment
- Precise and safe shaft fixation to the surface
- Material: aluminium



*Pictured is LSNS 20*



Dimensions											Designations	Mass	ISO series
D <sub>a</sub>	A	H ±0,01	H <sub>1</sub>	H <sub>2</sub>	H <sub>3</sub>	H <sub>4</sub>	J	L <sup>2)</sup>	N <sup>1)</sup>	N <sub>1</sub>	Shaft block	kg	-
12	20	20	6	35	13	16,5	30	43	5,3	M6	LSNS 12	0,06	3
16	24	25	7	42	18	21	38	53	6,6	M8	LSNS 16	0,11	3
20	30	30	7,5	50	22	25	42	60	8,4	M10	LSNS 20	0,17	3
25	38	35	8,5	61	26	30	56	78	10,5	M12	LSNS 25	0,34	3
30	40	40	9,5	70	26	34	64	87	10,5	M12	LSNS 30	0,46	3
40	48	50	11	90	34	44	82	108	13,5	M16	LSNS 40	0,90	3
50	58	60	11	105	43	49	100	132	17,5	M20	LSNS 50	1,45	3

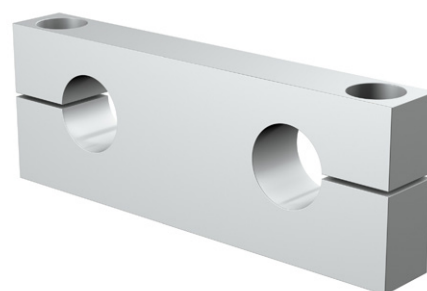
Items are usually available from stock.

<sup>1)</sup> For cylinder head screws with internal hexagon according to ISO 4762

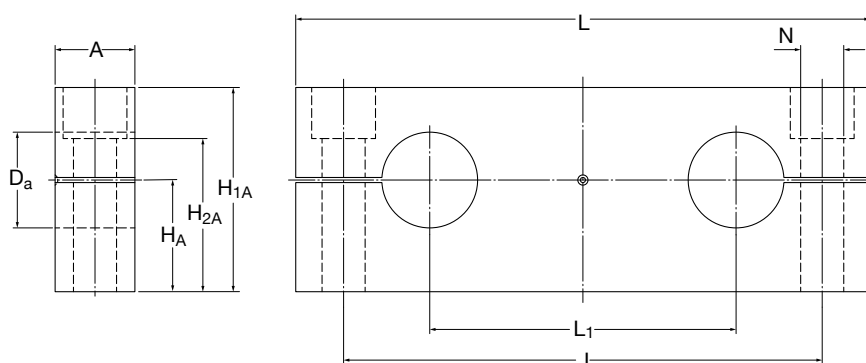
<sup>2)</sup> Tolerance L/2 ±0,01

### 3.6.4 Compact tandem shaft blocks - LEBS

- Designed for compact duo LTDR or quadro units LQBR
- Supports easy building up of linear slides
- Sizes from 12 mm to 50 mm
- Shaft clamping and bolt direction from the top
- Precise and safe shaft fixation to the surface
- Material: aluminium



Pictured is LEBS 30 A



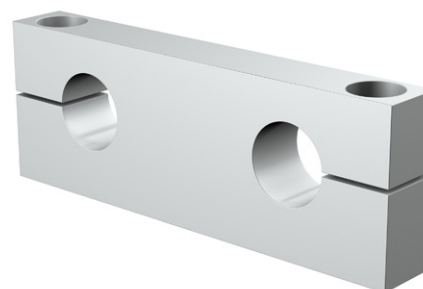
Dimensions									Designations	Mass	ISO series
$D_a$	A	$H_A$ $\pm 0,015$	$H_{1A}$	$H_{2A}$	J	L	$L_1$	N <sup>1)</sup>	Tandem shaft block Design A	Design A	
mm									-	kg	-
12	15	17	30	21,5	64	80	40	6,6	LEBS 12 A <sup>s)</sup>	0,08	1
16	15	19,5	35	26,5	80	96	52	6,6	LEBS 16 A <sup>s)</sup>	0,11	1
20	18	22	40	29	97	115	63	9	LEBS 20 A <sup>s)</sup>	0,17	1
25	20	27	50	36,5	115	136	75	11	LEBS 25 A <sup>s)</sup>	0,28	1
30	20	31	56	42,5	125	146	80	11	LEBS 30 A <sup>s)</sup>	0,32	1
40	25	38	70	54	160	184	97	13,5	LEBS 40 A <sup>s)</sup>	0,63	1
50	30	43	80	59	180	210	107	17,5	LEBS 50 A <sup>s)</sup>	0,90	1

<sup>s)</sup> Delivery time usually 10 days for max. quantity of 4; larger quantities on request

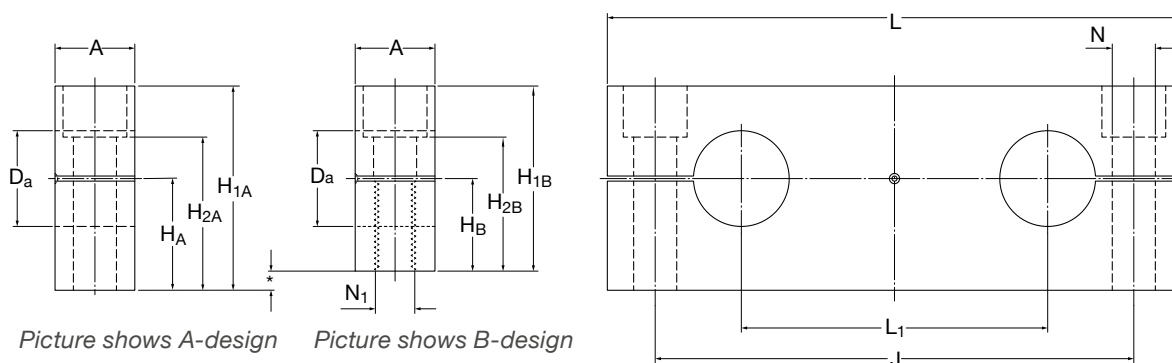
<sup>1)</sup> For cylinder head screws with internal hexagon according to ISO 4762

### 3.6.5 Standard tandem shaft blocks- LEAS

- Designed for standard quadro units LQCR or LQCD
- Supports easy building up of linear slides
- Sizes from size 8 mm to 50 mm in aluminium material
- Shaft clamping and bolt direction from the top
- Precise and safe shaft fixation to the surface
- LEAS A variant for moving quadro slide and fixed shaft blocks to surface
- LEAS B variant for moving shaft blocks and fixed quadro unit



Pictured is LEAS 30



Dimensions												
D <sub>a</sub>	A	H <sub>A</sub> ±0,015	H <sub>1A</sub>	H <sub>2A</sub>	H <sub>B</sub> ±0,015	H <sub>1B</sub>	H <sub>2B</sub>	J	L	L <sub>1</sub>	N <sup>1)</sup>	N <sub>1</sub>
mm												
8	12	12,5	23	16	11	22	15	52	65	32	5,5	M5
12	14	18	32	23,5	14	28	19,5	70	85	42	6,6	M6
16	18	20	37	26,5	17	34	23,5	82	100	54	9	M8
20	20	25	46	32,5	21	42	28,5	108	130	72	11	M10
25	25	30	56	40	26	52	36	132	160	88	13,5	M12
30	25	35	64	48	29	58	42	150	180	96	13,5	M12
40	30	44	80	59	36	72	51	190	230	122	17,5	M16
50	30	52	96	75	44	88	67	240	280	152	17,5	M16

Designations		Mass		ISO series
Tandem shaft block		Design		
Design		A	B	
A	B	kg		
-				-
LEAS 8 A <sup>s)</sup>	LEAS 8 B <sup>s)</sup>	0,04	0,04	3
LEAS 12 A <sup>s)</sup>	LEAS 12 B <sup>s)</sup>	0,09	0,07	3
LEAS 16 A <sup>s)</sup>	LEAS 16 B <sup>s)</sup>	0,14	0,13	3
LEAS 20 A <sup>s)</sup>	LEAS 20 B <sup>s)</sup>	0,25	0,22	3
LEAS 25 A <sup>s)</sup>	LEAS 25 B <sup>s)</sup>	0,47	0,44	3
LEAS 30 A <sup>s)</sup>	LEAS 30 B <sup>s)</sup>	0,62	0,56	3
LEAS 40 A <sup>s)</sup>	LEAS 40 B <sup>s)</sup>	1,15	1,00	3
LEAS 50 A <sup>s)</sup>	LEAS 50 B <sup>s)</sup>	1,70	1,52	3

<sup>s)</sup> Delivery time usually 10 days for max. quantity of 4; larger quantities on request

<sup>1)</sup> For cylinder head screws with internal hexagon according to ISO 4762

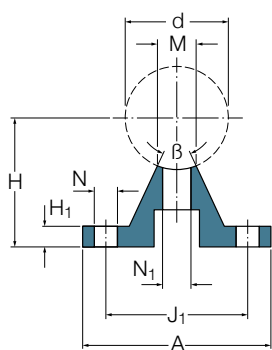
### 3.6.6 Standard shaft supports - LRCB/LRCC

- LRCB with mounting holes
- LRCC without mounting holes

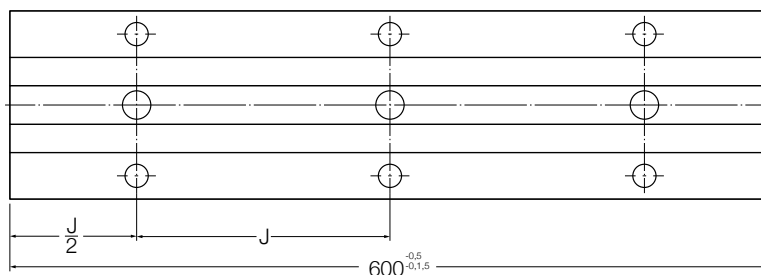
- Designed for all open type linear bearings and units
- Sizes from size 12 mm to 50 mm in aluminium material
- For complete or partial shaft support
- Able to bolt from top or bottom side to the surface
- LRCB with Ewellix standard shaft hole pattern ESSC6 (↳ chapter 3.7)
- LRCC machined for customised hole patterns



Pictured is LRCB



Picture shows LRCB



Dimensions									
d	A	H ±0,02	H <sub>1</sub>	J	J <sub>1</sub>	M	N <sup>1)</sup>	N <sub>1</sub> <sup>1)</sup>	β
mm									Deg.
12	40	22	5	75	29	5,8	4,5	4,5	50
16	45	26	5	100	33	7	5,5	5,5	50
20	52	32	6	100	37	8,3	6,6	6,6	50
25	57	36	6	120	42	10,8	6,6	9	50
30	69	42	7	150	51	11	9	11	50
40	73	50	8	200	55	15	9	11	50
50	84	60	9	200	63	19	11	13	46
60	94	68	10	300	72	25	11	15,5	46
80	116	86	12	300	92	34	13	17,5	46

Designations		Mass	Mass	Shaft attachment screw <sup>1)</sup>
with mounting holes	without mounting holes	LRCB	LRCC	
-	-	kg	kg	-
LRCB 12	LRCC 12 <sup>s)</sup>	0,44	0,46	M4×16
LRCB 16	LRCC 16 <sup>s)</sup>	0,55	0,56	M5×20
LRCB 20	LRCC 20 <sup>s)</sup>	0,8	0,81	M6×25
LRCB 25	LRCC 25 <sup>s)</sup>	0,9	0,92	M8×25
LRCB 30	LRCC 30 <sup>s)</sup>	1,13	1,18	M10×30
LRCB 40	LRCC 40 <sup>s)</sup>	1,6	1,62	M10×35
LRCB 50	LRCC 50 <sup>s)</sup>	2,1	2,16	M12×40
LRCB 60	LRCC 60 <sup>s)</sup>	2,37	2,41	M14×45
LRCB 80	LRCC 80 <sup>s)</sup>	4,9	4,99	M16×55

Items without letter footnote are usually available from stock.

<sup>s)</sup> Delivery time usually 10 days for max. quantity of 4; larger quantities on request

<sup>1)</sup> LRCB has holes for cylinder head screws with internal hexagon according to ISO 4762

# 3.7 Precision shafts

Ewellix precision shafts are high quality linear guide products for linear ball bearing use. Precision shafts have exceptionally high dimensional stability and are designed for long service life.

Shafts are induction hardened and ground, round steel bars, dimensionally made for the Ewellix linear ball bearing range. Precision shaft tolerances have a direct impact on the operating clearance of a linear bearing system. The hardness of the shaft plays a significant role in the rating life calculation. As shafts are the “inner ring of the linear bearing”, the quality

of these shafts matters for the safety and service life of your machines and devices.

Ewellix’s shaft range supports nearly every linear ball bearing application in material, dimensions and variants. The shafts are manufactured at long lengths to have best service and availability. Ewellix has defined standard shaft machinings and designated them as ESSC (Ewellix Standard Shaft Configurations) for convenient selection and order handling (→chapter3.7.7).

## 3.7.1 Shaft types and material

Shaft type	Material description		Steel designation		Size range	Hardness	Surface roughness Ra	Diameter tolerance	Factor for hardness of shaft <sup>2)</sup>	
-			EN	AISI	mm	HRC	µm	-	f <sub>h</sub>	f <sub>h0</sub>
LJM	solid	high grade steel	1.1213 (Cf53) <sup>1)</sup>	1055	3 – 80	62 ±2	0,3	h6	1,00	1,00
LJMR	solid	high alloy stainless steel	1.4112 (X90CrMoV18) <sup>1)</sup>	440B	3 – 60	54 ±2	0,3	h6	0,69	0,582
LJMS	solid	high alloy stainless steel	1.4034 (X46Cr13) <sup>1)</sup>	420	5 – 60	53 ±2	0,3	h6	0,66	0,532
LJMH	solid	high grade steel, hard chrome plated, ca. 10 µm	1.1213 (Cf53) <sup>1)</sup>	1055	5 – 80	62 ±2	0,3	h7	1,00	1,00
LJT	hollow	high grade steel	1.0601 (C60) <sup>1)</sup>	1060	12 – 80	62 ±2	0,3	h6	1,00	1,00

<sup>1)</sup> or equal

<sup>2)</sup> valid for minimal hardness values





## 3.7.2 Shaft hardness and depth

All Ewellix precision shafts are induction hardened. The hardness mainly depends on the material. The hardness per shaft type and the factors for hardness, influencing the rating life, are listed in **chapter 3.7.1**. The hardness depth is linked to the shaft size. Ewellix has defined the minimum hardness depths per shaft size in the table below. The hardness depth may also be higher than indicated in the table, please consider that influence on the machinability of the shafts. The ends of uncut shafts in production length may deviate in hardness and dimensional accuracy.

Hardness depths of shafts		
Shaft diameter from mm	up to	Hardness depth min.
3	10	0,4
12	16	0,6
20	30	0,9
40	50	1,5
60	80	2,2

Please be aware that all tolerances as well as the hardness and roughness of shafts have a great impact on the service life of your linear ball bearings. The influence is explained in the linear bearing rating life calculations in **chapter 2.2.3**.

## 3.7.3 Shaft corrosion resistance and protection

The Ewellix linear ball bearing range is available as a stainless steel variant in most types. The shaft range offers different types of high alloy stainless steel material or corrosion protection. Three types of material for corrosion protection are available:

- LJMR, a high alloy stainless steel shaft with high hardness, good wear resistance. This material is resistant to moderately aggressive media. This material is best for long corrosion resistance at high service life.
- LJMS, a high alloy stainless steel shaft like LJMR but with less hardness. This material is best for economic corrosion and media resistance.
- LJMH, a hard chrome plated, high grade steel shaft with excellent surface hardness due to the chrome layer. The corrosion resistance is along the chrome layer and does not exist at the cut surfaces. This material has medium corrosion resistance along the outside shape of the shaft.

### Corrosion protection and packaging

Ewellix precision shafts are treated with a rust inhibiting preservative that must be removed before the shafts are installed. Depending on size and quantity, precision shafts are supplied in cardboard or wooden boxes that offer maximum protection during transport. Please contact us for special freight conditions, like overseas shipping.

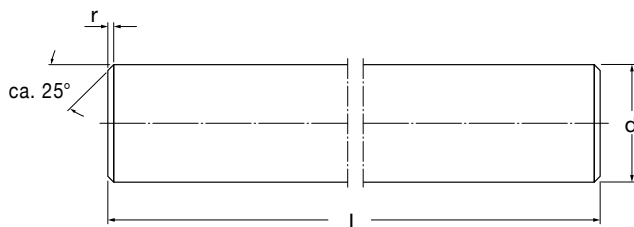
## 3.7.4 Precision shaft length

Maximum length and general length tolerance per shaft type						
Shaft diameter mm	Maximum length <sup>1)</sup>			LJMH	LJT	Length tolerance for maximum length
	LJM	LJMR	LJMS			
3 <sup>2)</sup>	1 000	300	–	–	–	±1,5
4 <sup>2)</sup>	3 000	3 000	–	–	–	±1,5
5	3 000	3 000	–	3 000	–	±1,5
6	3 000	3 000	3 000	3 000	–	±1,5
8	3 000	3 000	3 000	3 000	–	±1,5
10	3 000	3 000	3 000	3 000	–	±1,5
12	6 000	6 000	6 000	6 000	6 000	±1,5
14	6 000	6 000	6 000	6 000	–	±1,5
16	6 000	6 000	6 000	6 000	6 000	±1,5
20	6 000	6 000	6 000	6 000	6 000	±1,5
25	6 000	6 000	6 000	6 000	6 000	±1,5
30	6 000	6 000	6 000	6 000	6 000	±1,5
40	6 000	6 000	6 000	6 000	6 000	±1,5
50	6 000	6 000	6 000	6 000	6 000	±1,5
60	6 000	6 000	6 000	6 000	6 000	±1,5
80	6 000	–	–	6 000	6 000	±1,5

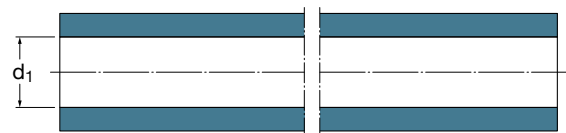
<sup>1)</sup> Maximum shaft length with both ends cut, means no deviation of hardness or dimensional accuracy.

<sup>2)</sup> Only available as ESSC 2, see **chapter 3.7.7**

### 3.7.5 Technical data of precision shafts



Picture shows solid shaft with shafting standard ESSC 3



Picture shows hollow shaft with shafting standard ESSC 1

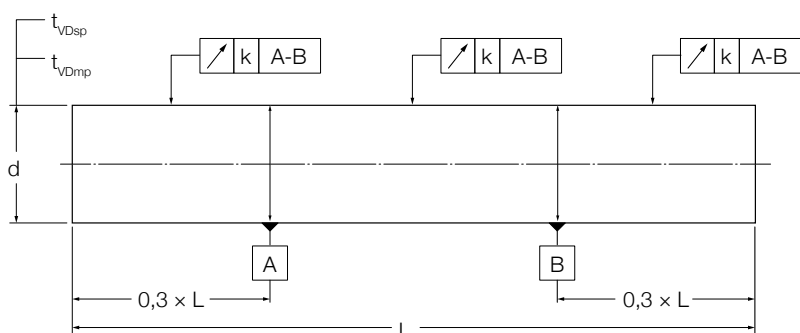
Dimensions			Mass		Moment of inertia		Cross sectional area		Designation				
d	d <sub>1</sub>	r <sup>1)</sup>	Solid shaft	Hollow shaft	Solid shaft	Hollow shaft	Solid shaft	Hollow shaft	Solid shaft			Hollow shaft	
mm			kg/m		cm <sup>4</sup>		mm <sup>2</sup>		-				
3	-	0,4	0,06	-	0,0004	-	7,1	-	LJM 3	LJMR 3	-	-	-
4	-	0,4	0,1	-	0,0013	-	12,6	-	LJM 4	LJMR 4	-	-	-
5	-	0,8	0,15	-	0,0031	-	19,6	-	LJM 5	LJMR 5	-	LJMH 5	-
6	-	0,8	0,22	-	0,0064	-	28,3	-	LJM 6	LJMR 6	LJMS 6	LJMH 6	-
8	-	0,8	0,39	-	0,02	-	50,3	-	LJM 8	LJMR 8	LJMS 8	LJMH 8	-
10	-	0,8	0,62	-	0,049	-	78,5	-	LJM 10	LJMR 10	LJMS 10	LJMH 10	-
12	4	1	0,89	0,79	0,102	0,1	113	101	LJM 12	LJMR 12	LJMS 12	LJMH 12	LJT 12
14	-	1	1,21	-	0,189	-	154	-	LJM 14	LJMR 14	LJMS 14	LJMH 14	-
16	7	1	1,58	1,28	0,322	0,31	201	163	LJM 16	LJMR 16	LJMS 16	LJMH 16	LJT 16
20	14	1,5	2,47	1,25	0,785	0,597	314	160	LJM 20	LJMR 20	LJMS 20	LJMH 20	LJT 20
25	16 <sup>2)</sup>	1,5	3,86	2,35	1,92	1,64	491	305	LJM 25	LJMR 25	LJMS 25	LJMH 25	LJT 25
30	18 <sup>2)</sup>	1,5	5,55	3,5	3,98	3,46	707	453	LJM 30	LJMR 30	LJMS 30	LJMH 30	LJT 30
40	28 <sup>2)</sup>	2	9,86	4,99	12,6	9,96	1 260	685	LJM 40	LJMR 40	LJMS 40	LJMH 40	LJT 40
50	30	2	15,4	9,91	30,7	27,7	1 960	1 350	LJM 50	LJMR 50	LJMS 50	LJMH 50	LJT 50
60	36	2,5	22,2	14,2	63,6	57,1	2 830	1 920	LJM 60	LJMR 60	LJMS 60	LJMH 60	LJT 60
80	57	2,5	39,5	19,43	201	153	5 030	2 565	LJM 80	-	-	LJMH 80	LJT 80

<sup>1)</sup> The values r given in that table represent the minimum values of r.

<sup>2)</sup> d<sub>1</sub> can deviate from the given value. Please enquire if necessary

### 3.7.6 Tolerances of precision shafts

All Ewellix precision shafts are supplied in high quality tolerance h6 as standard. Only hard chrome plated shafts LJMh are supplied in tolerance h7. The accuracy of dimensions and form are in the table below. When shafts are annealed and machined, there may be slight deviations from the values provided in the tables for those sections. The length tolerance of shafts cut to length is  $\pm 1,5$ mm as standard.



Definition of shaft tolerances is according to ISO 13012-1

Shaft Nominal diameter	Accuracy of dimension and form									
	Shafts in tolerance h6					Shafts in tolerance h7				
d mm	t <sub>Δds</sub> upper limit μm	lower limit	t <sub>VDsp</sub>	t <sub>VDmp</sub>	k run-out μm/m	t <sub>Δds</sub> upper limit μm	lower limit	t <sub>VDsp</sub>	t <sub>VDmp</sub>	k run-out μm/m
3	0	-6	3	4	150	0	-10	4	6	150
4	0	-8	4	5	150	0	-12	5	8	150
5	0	-8	4	5	150	0	-12	5	8	150
6	0	-8	4	5	150	0	-12	5	8	150
8	0	-9	4	6	120	0	-15	6	9	120
10	0	-9	4	6	120	0	-15	6	9	120
12	0	-11	5	8	100	0	-18	8	11	100
14	0	-11	5	8	120	0	-18	8	11	120
16	0	-11	5	8	100	0	-18	8	11	100
20	0	-13	6	9	100	0	-21	9	13	100
25	0	-13	6	9	100	0	-21	9	13	100
30	0	-13	6	9	100	0	-21	9	13	100
40	0	-16	7	11	100	0	-25	11	16	100
50	0	-16	7	11	100	0	-25	11	16	100
60	0	-19	8	13	100	0	-30	13	19	100
80	0	-19	8	13	100	0	-30	13	19	100

## 3.7.7 Machined precision shafts

### Ewellix Shaft Standard Configuration - ESSC

For machined shafts, Ewellix has defined standard configurations widely used in linear ball bearing applications. It mainly specifies how both shaft ends and solutions with radial holes for shaft support look like. These standard choices have to be mentioned in the ordering key of a shaft. For example, the designation for a shaft with 20 mm diameter cut to a length of 1,5 m and with chamfers, is LJM 20x1500 ESSC 2. For customised shaft solutions according to customer drawing, the suffix is ESSC 10 in the ordering key.

### Precision shafts with radial holes

For open type linear ball bearings, shafts with radial holes mounted on shaft supports are needed. Ewellix has defined a design standard for radial threads and distances for easy documentation and the definition of a connection of shafts with shaft supports. Shaft supports are shown in **chapter 3.6.6**. The radial holes may be either positioned to fit Ewellix shaft supports (suffix ESSC 6) or as specified by the customer (suffix ESSC 7). Also, use the values for thread size and depth from adjacent tables when creating your own shaft design. Ewellix shafts with radial holes are not annealed at the drilling position. The thread is cut in the hardened and ground shaft to avoid any changes in hardness or dimensional accuracy.

### Jointed precision shafts

In case shafts longer than the maximum length (↳ **chapter 3.7.4**) are needed, Ewellix can supply jointed shafts on request. Screwed joints are recommended for unsupported shafts. Plug and socket joints are used with supported shafts. Ewellix takes great care to provide accurately machined joints, e.g. regarding concentricity, as they are vital for smooth transitions at the joints.

A customer drawing with details and defined joint positions is necessary to handle a request or order. The ordering key suffix for a customised solution is ESSC 10.

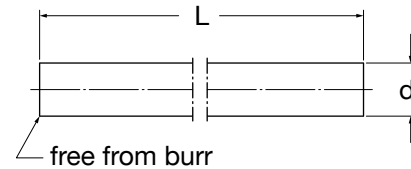
**Dimensions of front side threads ESSC 4 and 5**

d mm	G –	L <sub>s</sub> mm
8	M4	10
10	M4	10
12	M5	12,5
14	M5	12,5
16	M6	15
20	M8	20
25	M10	25
30	M10	25
40	M12	30
50	M16	40
60	M20	50
80	M24	60

## ESSC definitions

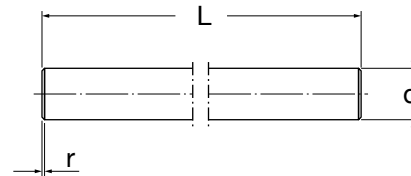
### ESSC 1

- Shaft cut to length and deburred
- Length tolerance  $\pm 1,5$  mm



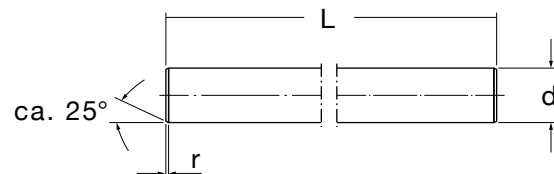
### ESSC 2

- Shaft cut to length with chamfer
- Chamfer with r value of minimum 1 mm
- Length tolerance  $\pm 1,5$  mm



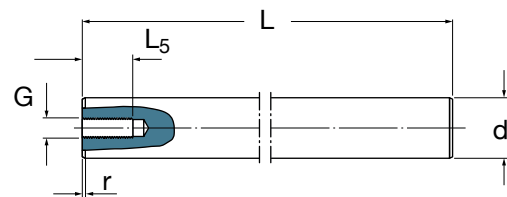
### ESSC 3

- Shaft cut to length with chamfer ca. 25°
- With machined front surface 90°
- Length tolerance  $\pm 0,1$  mm up to 3 m length
- Chamfer with r value according to **chapter 3.7.5**



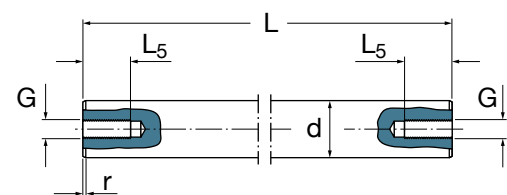
### ESSC 4

- Shaft cut to length with chamfer
- With machined front surface 90°
- Length tolerance  $\pm 0,1$  mm up to 3 m length
- Chamfer with r value according to **chapter 3.7.5**
- With one axial thread; dimensions according table



### ESSC 5

- Shaft cut to length with chamfer
- With machined front surface 90°
- Length tolerance  $\pm 0,1$  mm up to 3 m length
- Chamfer with r value according to **chapter 3.7.5**
- With two axial threads; dimensions according table



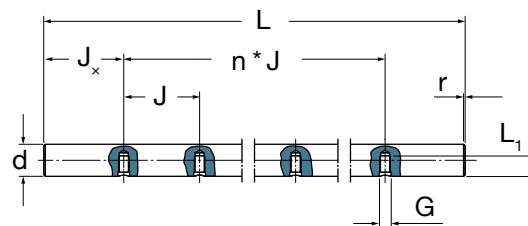
Delivery times depend on the shaft machining:

ESSC 1-3 usually within 10 days

ESSC 4-8 usually within 20 days

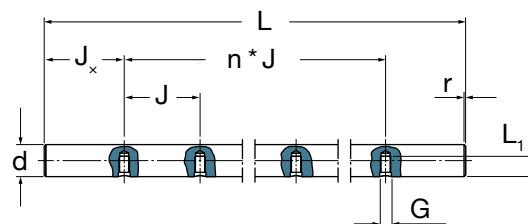
**ESSC 6**

- Shaft cut to length with chamfer
- Chamfer with r value of minimum 1 mm
- Length tolerance  $\pm 1,5$  mm
- Shaft with radial threads for LRCB shaft supports
- First radial thread position at  $J_x = J/2$



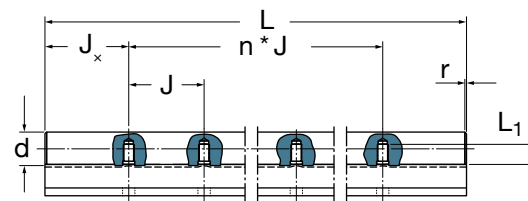
**ESSC 7**

- Shaft cut to length with chamfer
- Chamfer with r value of minimum 1 mm
- Length tolerance  $\pm 1,5$  mm
- Shaft with radial threads
- Dimension J and  $J_x$  as specified in customer's drawing



**ESSC 8**

- Shaft cut to length with chamfer
- Chamfer with r value of minimum 1 mm
- Length tolerance  $\pm 1,5$  mm
- Shaft with radial threads for LRCB shaft supports
- First radial thread position at  $J_x = J/2$
- Shaft fully supported and mounted with LRCB shaft supports



**ESSC 10**

- Shaft according customer drawing

**Dimensions of radial threads ESSC 6, 7 and 8**

d mm	G	$L_1$	J	$J_x$
8	–	–	–	–
10	–	–	–	–
12	M4	8	75	37,5
14	–	–	–	–
16	M5	9,5	100	50
20	M6	13	100	50
25	M8	14	120	60
30	M10	18	150	75
40	M10	20	200	100
50	M12	23	200	100
60	M14	28	300	150
80	M16	33	300	150

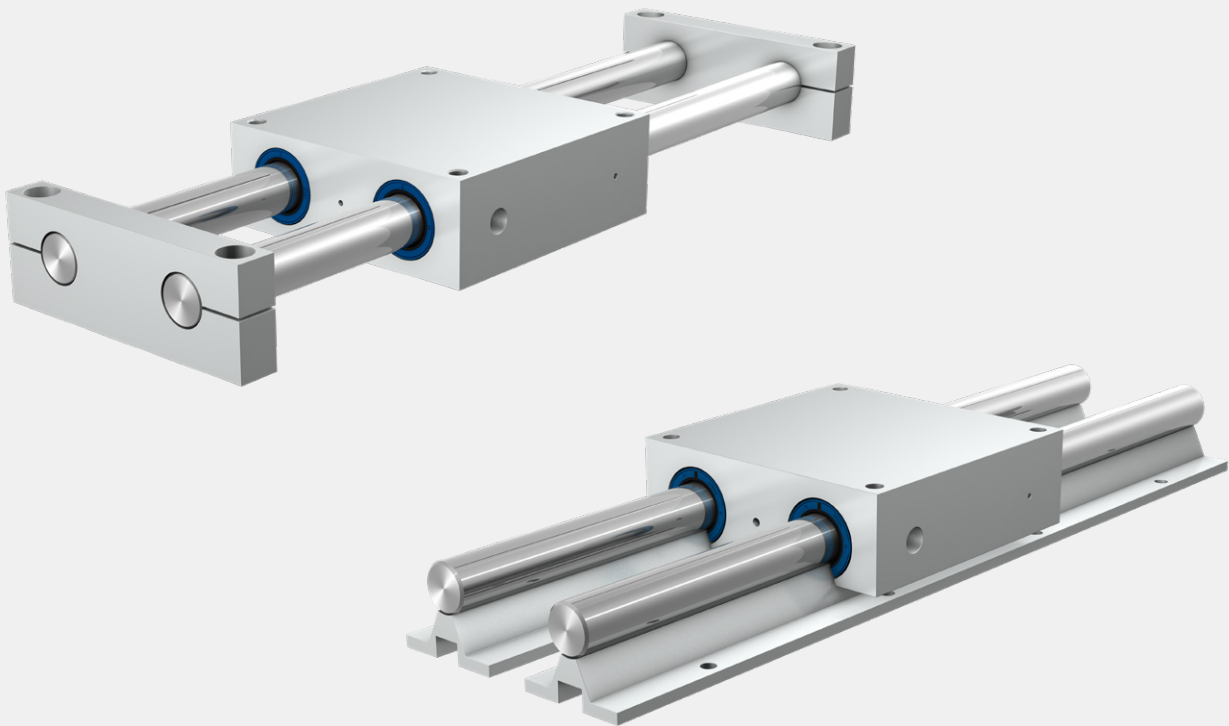
## 3.8 Linear slides

LZ slides are complete linear bearing slides for manual motion where all the required components are delivered as a kit. Only the length of the slide system must be determined and the rest is predefined. LZ slides are easy to use, customer friendly linear motion solutions. LZ slides are quadro unit based slides with shafts and shaft blocks or supports. The bearing unit is equipped with four LBCD or LBCF self-aligning linear ball bearings.

Three different variants exist to fit nearly every application. The LZBU-“A” variant enables axial movement of the quadro unit, whereby the shafts are fixed via the tandem shaft blocks to the machine surface. The LZBU-“B” variant is provided with LEAS-“B” shaft blocks. This combination is made for moving linear shafts and shaft blocks while the

quadro unit is fixed to the machine. LZAU are the open type linear slides made for longer travel distances with shaft supports.

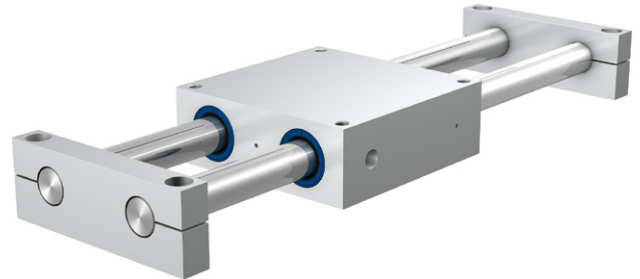
All slides can be supplied with stainless steel bearings and shafts. The slides are always equipped with linear bearings that have seals on the outside. LZAU linear slides can be supplied from size 12 mm to 50 mm, where LZBU slides are available from 8 mm to 50 mm. The bearing unit is factory pre-lubricated and ready for use. In case relubrication is needed, the units are equipped with grease fittings on either side. Only size 8 must be relubricated via the shafts.



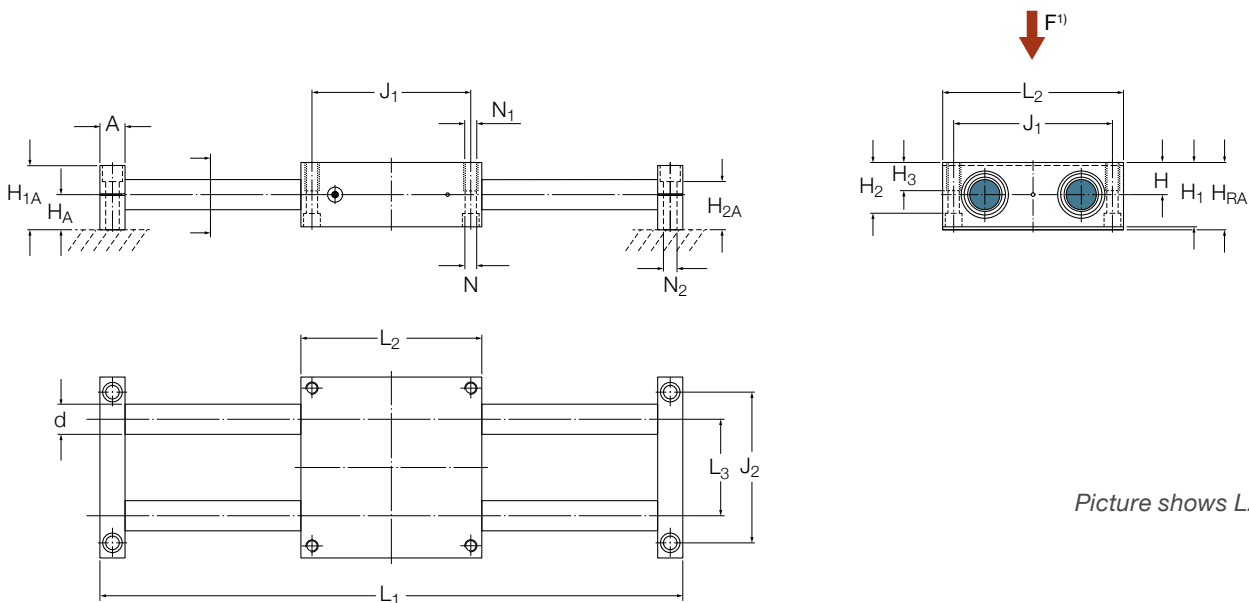
### 3.8.1 Linear slides - LZBU A

- Designed for fixed shaft blocks and moving quadro unit

- Sizes from 8 mm to 50 mm
- Equipped with 4 self-aligning LBCD bearings
- Sealed standard and stainless steel variant
- Factory pre-lubricated with SKF LGEP 2 grease, ready for use
- Equipped with grease fittings on both sides
- Quadro unit able to bolt from top or bottom side
- Standard slides consist of the following parts:
  - One standard quadro unit LQCD -2LS
  - Two tandem shaft blocks LEAS-A
  - Two precision shafts LJM of the defined length
  - Stainless slides with LQCD -2LS/HV6 variant and LJMR precision shafts



Pictured is LZBU 30 A-2LS <sup>2)</sup>



Picture shows LZBU...A

**Dimensions**

d	A	H <sub>RA</sub> ±0,03	H <sub>A</sub> ±0,015	H <sub>1A</sub>	H <sub>2A</sub>	H ±0,01	H <sub>1</sub>	H <sub>2</sub>	H <sub>3</sub>	J <sub>1</sub>	J <sub>2</sub>	L <sub>1</sub> <sup>3)</sup>	L <sub>2</sub>	L <sub>3</sub>	N <sup>2)</sup>	N <sub>1</sub>	N <sub>2</sub> <sup>2)</sup>
mm																-	mm
8	12	24	12,5	23	16	11,5	23	17,5	11	55	52	600	65	32	4,3	M5	5,5
12	14	34	18	32	23,5	16	32	25	13	73	70	900	85	42	5,3	M6	6,6
16	18	38	20	37	26,5	18	36	29	13	88	82	1500	100	54	5,3	M6	9
20	20	48	25	46	32,5	23	46	37,5	18	115	108	1800	130	72	6,6	M8	11
25	25	58	30	56	40	28	56	45	22	140	132	1800	160	88	8,4	M10	13,5
30	25	67	35	64	48	32	64	50,5	26	158	150	2400	180	96	10,5	M12	13,5
40	30	84	44	80	59	40	80	64	34	202	190	3000	230	122	13,5	M16	17,5
50	30	100	52	96	75	48	96	80	34	250	240	3000	280	152	13,5	M16	17,5

<sup>1)</sup> Direction for max. load ratings

<sup>2)</sup> Picture with non D-series bearing differs

<sup>3)</sup> Recommended maximum shaft length. On demand, longer shaft lengths are available. Length tolerance according ESSEC2 shafting standard.

<sup>4)</sup> For cylinder head screws with internal hexagon according to ISO 4762



## LZBU... A

Designations <sup>1)</sup>	Basic load ratings			
	dynamic C		static C <sub>0</sub>	
–	min N	max	min	max
LZBU 8 A-2LS <sup>2) n)</sup>	1 290	1 500	1 430	2 000
LZBU 12 A-2LS <sup>n)</sup>	2 120	3 200	2 280	3 750
LZBU 16 A-2LS <sup>n)</sup>	2 500	3 650	2 600	4 250
LZBU 20 A-2LS <sup>n)</sup>	4 550	6 700	4 500	7 200
LZBU 25 A-2LS <sup>n)</sup>	6 800	10 000	5 700	9 300
LZBU 30 A-2LS <sup>n)</sup>	10 000	14 600	9 300	15 000
LZBU 40 A-2LS <sup>n)</sup>	17 300	25 500	13 400	22 800
LZBU 50 A-2LS <sup>n)</sup>	21 200	30 000	16 600	28 000

## LZBU... A stainless

Designations <sup>1)</sup>	Basic load ratings <sup>3)</sup>			
	dynamic C		static C <sub>0</sub>	
–	min N	max	min	max
LZBU 8 A-2LS/HV6 <sup>2) n)</sup>	1 020	1 200	1 020	1 400
LZBU 12 A-2LS/HV6 <sup>n)</sup>	1 700	2 550	1 600	2 650
LZBU 16 A-2LS/HV6 <sup>n)</sup>	2 000	2 900	1 830	3 000
LZBU 20 A-2LS/HV6 <sup>n)</sup>	3 600	5 300	3 200	5 100
LZBU 25 A-2LS/HV6 <sup>n)</sup>	5 400	8 000	4 000	6 550
LZBU 30 A-2LS/HV6 <sup>n)</sup>	8 000	11 600	6 550	10 600
LZBU 40 A-2LS/HV6 <sup>n)</sup>	13 700	20 400	9 500	16 000
LZBU 50 A-2LS/HV6 <sup>n)</sup>	17 000	23 600	11 800	19 600

<sup>n)</sup> Delivery time on request

<sup>1)</sup> The designation for a LZBU linear slide with a shaft length of, for instance 1200 mm, is LZBU .. A-2LSx1200. Parts delivered as a kit

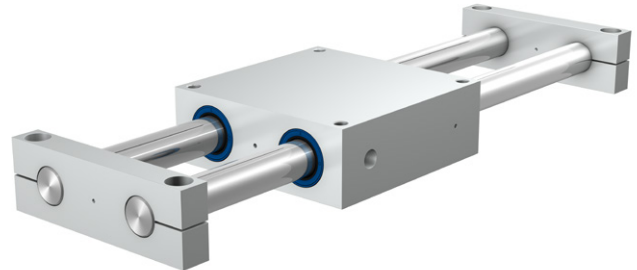
<sup>2)</sup> Slides in size 8 mm must be relubricated via the shaft and are equipped with rigid LBCR linear bearings

<sup>3)</sup> Calculated with HRC 54 due to stainless shafts

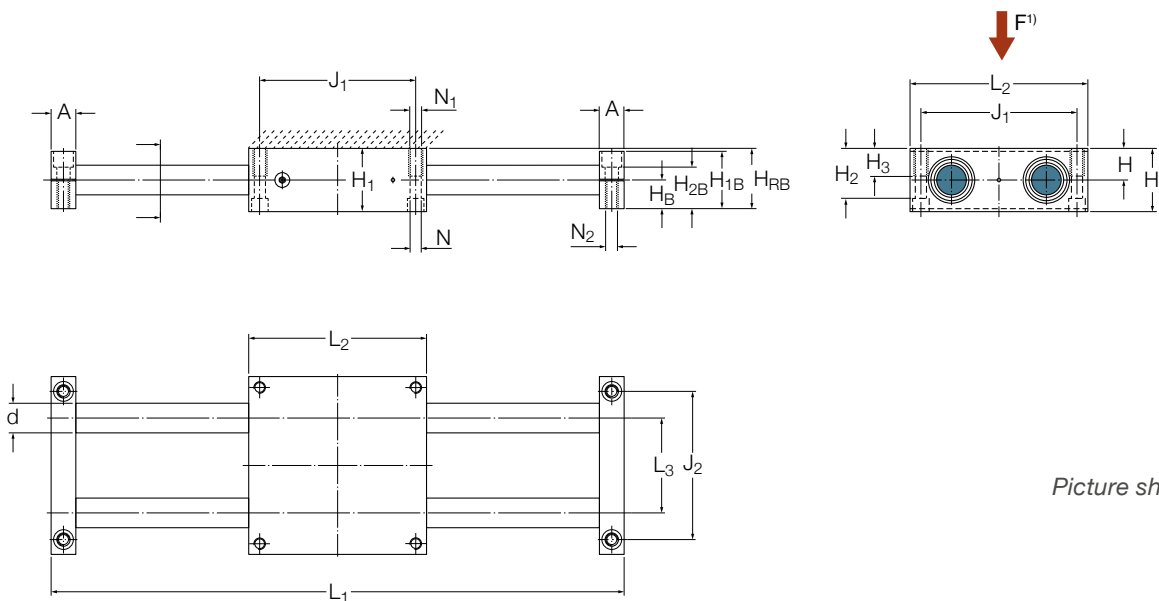
### 3.8.2 Linear slides - LZBU B

- Designed for fixed quadro unit and moving shaft blocks

- Sizes from 8 mm to 50 mm
- Equipped with 4 self-aligning LBCD bearings
- Sealed standard and stainless steel variant
- Factory pre-lubricated with SKF LGEP 2 grease, ready for use
- Equipped with grease fittings on both sides
- Quadro unit able to bolt from top or bottom side
- Standard slides consist of the following parts:
  - One standard quadro unit LQCD -2LS
  - Two tandem shaft blocks LEAS-B
  - Two precision shafts LJM of the defined length
  - Stainless slides with LQCD -2LS/HV6 variant and LJMR precision shafts



Pictured is LZBU 30 B-2LS <sup>2)</sup>



Picture shows LZBU...B

**Dimensions**

d	A	H <sub>RB</sub> ±0,03	H <sub>B</sub> ±0,015	H <sub>1B</sub>	H <sub>2B</sub>	H ±0,01	H <sub>1</sub>	H <sub>2</sub>	H <sub>3</sub>	J <sub>1</sub>	J <sub>2</sub>	L <sub>1</sub> <sup>3)</sup>	L <sub>2</sub>	L <sub>3</sub>	N <sup>4)</sup>	N <sub>1</sub>	N <sub>2</sub> <sup>4)</sup>
8	12	22,5	11	22	15	11,5	23	17,5	11	55	52	600	65	32	4,3	M5	M5
12	14	30	14	28	19,5	16	32	25	13	73	70	900	85	42	5,3	M6	M6
16	18	35	17	34	23,5	18	36	29	13	88	82	1 500	100	54	5,3	M6	M8
20	20	44	21	42	28,5	23	46	37,5	18	115	108	1 800	130	72	6,6	M8	M10
25	25	54	26	52	36	28	56	45	22	140	132	1 800	160	88	8,4	M10	M12
30	25	61	29	58	42	32	64	50,5	26	158	150	2 400	180	96	10,5	M12	M12
40	30	76	36	72	51	40	80	64	34	202	190	3 000	230	122	13,5	M16	M16
50	30	92	44	88	67	48	96	80	34	250	240	3 000	280	152	13,5	M16	M16

<sup>1)</sup> Direction for max. load ratings

<sup>2)</sup> Picture with non D-series bearing differs

<sup>3)</sup> Recommended maximum shaft length. On demand, longer shaft lengths are available. Length tolerance according ESSC2 shafting standard.

<sup>4)</sup> For cylinder head screws with internal hexagon according to ISO 4762

## LZBU... B

Designations <sup>1)</sup>	Basic load ratings			
	dynamic C		static C <sub>0</sub>	
–	min N	max	min	max
LZBU 8 B-2LS <sup>2) n)</sup>	1 290	1 500	1 430	2 000
LZBU 12 B-2LS <sup>n)</sup>	2 120	3 200	2 280	3 750
LZBU 16 B-2LS <sup>n)</sup>	2 500	3 650	2 600	4 250
LZBU 20 B-2LS <sup>n)</sup>	4 550	6 700	4 500	7 200
LZBU 25 B-2LS <sup>n)</sup>	6 800	10 000	5 700	9 300
LZBU 30 B-2LS <sup>n)</sup>	10 000	14 600	9 300	15 000
LZBU 40 B-2LS <sup>n)</sup>	17 300	25 500	13 400	22 800
LZBU 50 B-2LS <sup>n)</sup>	21 200	30 000	16 600	28 000

## LZBU... B stainless

Designations <sup>1)</sup>	Basic load ratings <sup>3)</sup>			
	dynamic C		static C <sub>0</sub>	
–	min N	max	min	max
LZBU 8 B-2LS/HV6 <sup>2) n)</sup>	1 020	1 200	1 020	1 400
LZBU 12 B-2LS/HV6 <sup>n)</sup>	1 700	2 550	1 600	2 650
LZBU 16 B-2LS/HV6 <sup>n)</sup>	2 000	2 900	1 830	3000
LZBU 20 B-2LS/HV6 <sup>n)</sup>	3 600	5 300	3 200	5 100
LZBU 25 B-2LS/HV6 <sup>n)</sup>	5 400	8 000	4 000	6 550
LZBU 30 B-2LS/HV6 <sup>n)</sup>	8 000	11 600	6 550	10 600
LZBU 40 B-2LS/HV6 <sup>n)</sup>	13 700	20 400	9 500	16 000
LZBU 50 B-2LS/HV6 <sup>n)</sup>	17 000	23 600	11 800	19 600

<sup>n)</sup> Delivery time on request

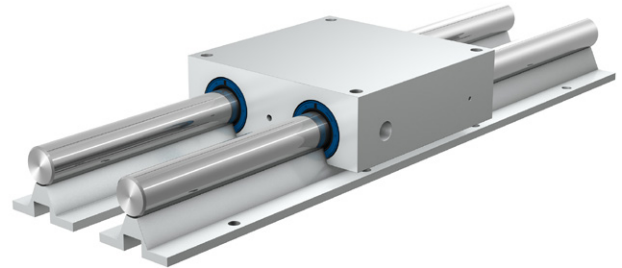
<sup>1)</sup> The designation for a LZBU linear slide with a shaft length of, for instance 1200 mm, is LZBU .. B-2LSx1200. Parts delivered as a kit

<sup>2)</sup> Slides in size 8 mm must be relubricated via the shaft and are equipped with rigid LBCR linear bearings

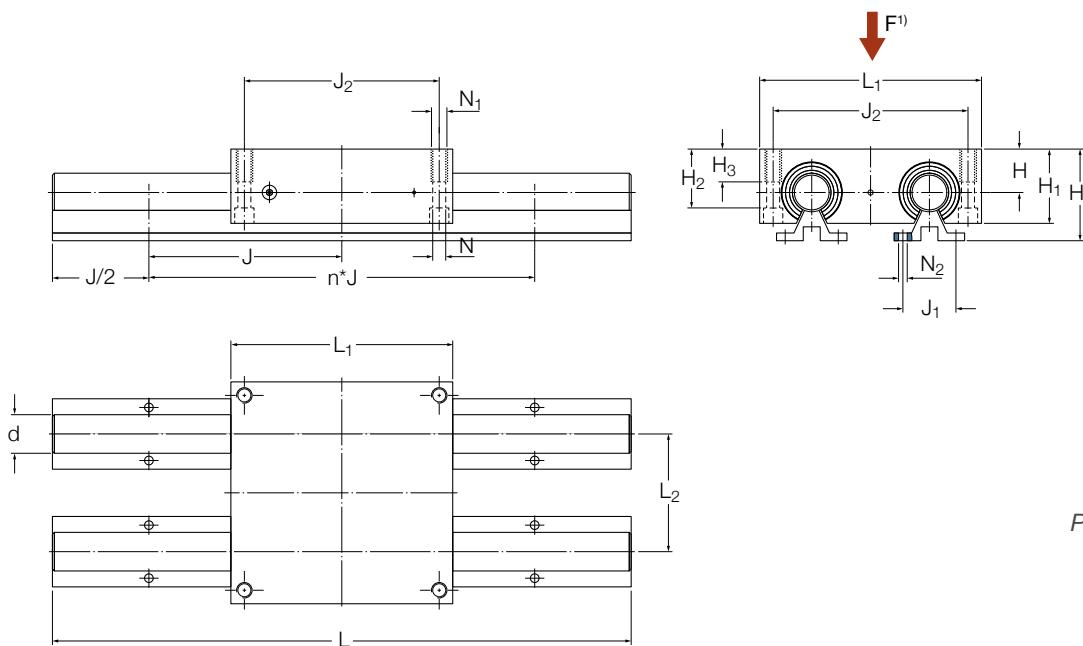
<sup>3)</sup> Calculated with HRC 54 due to stainless shafts

### 3.8.3 Linear slides - LZAU

- Open design from sizes 12 mm to 50 mm
- Equipped with 4 self-aligning LBCF bearings
- Sealed standard and stainless steel variant
- Factory pre-lubricated with SKF LGEP 2 grease, ready for use
- Equipped with grease fittings on both sides
- Quadro unit able to bolt from top or bottom side
- Standard slides consist of the following parts:
  - One standard quadro unit LQCF -2LS
  - Two precision shafts LJM of the defined length supported by LRCB shaft supports
  - Stainless slides with LQCF -2LS/HV6 variant and LJMR precision shafts



Pictured is LZAU 30-2LS <sup>2)</sup>



Picture shows LZAU

**Dimensions**

d	H <sub>T</sub> ±0,03	H ±0,01	H <sub>1</sub>	H <sub>2</sub>	H <sub>3</sub>	J <sup>3)</sup>	J <sub>1</sub>	J <sub>2</sub>	L <sub>1</sub>	L <sub>2</sub>	N <sup>2)</sup>	N <sub>1</sub>	N <sub>2</sub> <sup>2)</sup>
mm												-	mm
12	40	18	30	23,4	13	75	29	73	85	42	5,3	M6	4,5
16	48	22	35	28,4	13	100	33	88	100	54	5,3	M6	5,5
20	57	25	42	33,5	18	100	37	115	130	72	6,6	M8	6,6
25	66	30	51	40	22	120	42	140	160	88	8,4	M10	6,6
30	77	35	60	46,5	26	150	51	158	180	96	10,5	M12	9
40	95	45	77	61	34	200	55	202	230	122	13,5	M16	9
50	115	55	93	77	34	200	63	250	280	152	13,5	M16	11

<sup>1)</sup> Direction for max. load ratings

<sup>2)</sup> Picture with non D-series bearing differs

<sup>3)</sup> Shaft with shafting standard ESSE 8 is used.

<sup>4)</sup> For cylinder head screws with internal hexagon according to ISO 4762

## LZAU

Designations <sup>1)</sup>	Basic load ratings			
	dynamic C		static C <sub>0</sub>	
–	min N	max	min	max
LZAU 12-2LS <sup>n)</sup>	1 600	2 850	1 660	3 400
LZAU 16-2LS <sup>n)</sup>	1 760	3 450	1 930	4 500
LZAU 20-2LS <sup>n)</sup>	3 900	6 550	3 650	7 350
LZAU 25-2LS <sup>n)</sup>	6 000	10 200	4 900	9 800
LZAU 30-2LS <sup>n)</sup>	8 650	15 000	7 800	15 600
LZAU 40-2LS <sup>u)</sup>	14 600	25 000	12 000	23 600
LZAU 50-2LS <sup>n)</sup>	12 900	30 000	12 000	28 000

## LZAU stainless

Designations <sup>1)</sup>	Basic load ratings <sup>2)</sup>			
	dynamic C		static C <sub>0</sub>	
–	min N	max	min	max
LZAU 12-2LS/HV6 <sup>n)</sup>	1 270	2 280	1 180	2 400
LZAU 16-2LS/HV6 <sup>n)</sup>	1 400	2 750	1 370	3 200
LZAU 20-2LS/HV6 <sup>n)</sup>	3 100	5 200	2 600	5 200
LZAU 25-2LS/HV6 <sup>n)</sup>	4 750	8 150	3 450	6 950
LZAU 30-2LS/HV6 <sup>n)</sup>	6 800	11 800	5 500	11 000
LZAU 40-2LS/HV6 <sup>u)</sup>	11 600	20 000	8 500	16 600
LZAU 50-2LS/HV6 <sup>n)</sup>	10 200	23 600	8 500	19 600

<sup>n)</sup> Delivery time on request

<sup>u)</sup> Size 40 under development; A-design unit is available until replacement

<sup>1)</sup> The designation for a LZAU linear slide with a shaft length of, for instance 600 mm, is LZAU ...2LSx600. Parts delivered as a kit

<sup>2)</sup> Calculated with HRC 54 due to stainless shafts

4

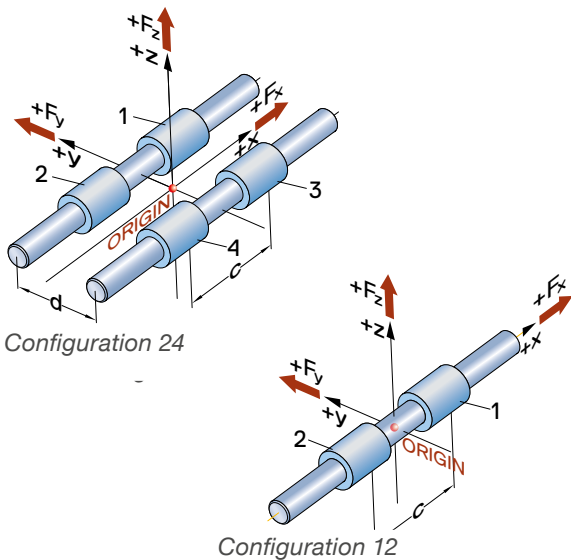
**Mounting, operation  
and maintenance  
manual**



# 4.1 Design rules

## 4.1.1 How to use linear bearings

A typical linear slide arrangement consists of four linear bearings mounted inside housings and two suitable shafts (configuration 24). Another design possibility is to use a single shaft with two bearings (configuration 12), e.g. used in sliding doors for trains. If using configuration 12, it's important that additional means, e.g. a support roller, prevent rotation of the bearing around the shaft (see more about loads on configuration 12 in **chapter 2.2.2**). Ewellix generally recommends using two bearings per shaft. In exceptional circumstances, e.g. when no torque loads occur or loads are very light, it is possible to use a single linear ball bearing arrangement (configuration 11 or 22).



Closed design linear bearings and units have excellent sealing capabilities and are easy to install. They are mostly used for applications with shorter shafts, where the impact of shaft bending is limited (see more about misalignment in **chapter 2.2.3**). For long arrangements, especially when heavily loaded, the use of open design linear ball bearings is recommended. They allow the use of supported shafts that do not bend.

To use the linear bearing with its full performance, several guidelines regarding housing design, shaft specification, mounting surfaces and mounting have to be considered as the next chapters describe. All Ewellix components in this catalogue are designed according to these rules. That's why we recommend the use of original Ewellix parts.

## 4.1.2 Housing design

A linear ball bearing needs a housing that gives adequate support for the raceway plates. The diameter tolerance, cylindricity and surface roughness of the housing bore are important criteria for the performance of a linear ball bearing system.

A housing bore adequate for the self-holding function of compact series ball bearings and plain bearings, requires a diameter with tolerance J6 or J7. For standard bearings, the housing bore tolerance should be at least H6 or H7. Generally, the housing bore tolerances in combination with the tolerances of a certain bearing type and the tolerances of the shaft result in the operating clearance of the linear guiding system (see more about operating clearance in **chapter 2.1.2**). That means the operating clearance can be reduced by choosing tolerance J or K for the housing bore.

Cylindricity tolerance, according to DIN EN ISO 1101:

- 1 or 2 IT grades better than the dimensional tolerance is recommended

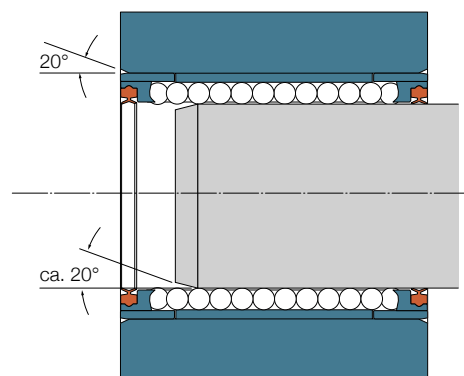
Surface roughness Ra in the housing bore (guideline values):

- Diameter tolerance IT7: Ra = 1,6  $\mu\text{m}$
- Diameter tolerance IT6: Ra = 0,8  $\mu\text{m}$

To facilitate mounting, the housing bore should have a chamfer of approximately 20° (→ **fig. 1**). This simplifies the insertion of the bearing in its housing.



**Fig. 1**  
Chamfers on housing bore and shaft



### 4.1.3 Bearing fixation

Compact linear ball bearings LBBR have two plastic end rings with an outside diameter slightly larger than the nominal diameter of the bearing. This extra diameter together with a housing bore tolerance of J7 or J6 provides the requisite tightness for the self-holding functionality of the compact bearing. No additional fixation of the bearing is needed as long as the housing covers the whole bearing length and the environmental and application conditions are normal.

All standard linear ball bearings and linear plain bearings must be fixed in the housing. Therefore, holes are provided in the outside diameter of the bearings in which stops can be inserted to prevent the bearing from rotation and axial movement. The face side of the bearing has a small circle (D-design) or hatched surface (A-design) to mark the position of the lubrication port. The position and diameter of the holes in the bearing's outside diameter are shown in **tables 1 to 4**.

These holes also act as a lubrication port. When using Ewellix grease fittings, designation VN-LHC (↳ **fig. 2**), you can utilize both functions: relubrication and mandatory fixation of the bearing in the housing. The use of VN-LHC grease fittings is recommended and they are also used for this purpose in Ewellix linear bearing units. Please find details about the grease fitting in **chapter 3.3.7**.

**NOTE:** For defined bearing orientation: As the bearings main load direction and the hole for bearing fixation are under 90°, make sure that the housing design, especially the hole for bearing fixation, is aligned with the factor for direction of load used for rating life calculation (↳ **chapter 2.2.3**).

The following other parts beside the grease fittings can be used as a fixation element:

- Grub screws according to DIN EN 27435 or DIN EN ISO 4028
- Straight pins according to DIN EN ISO 2338
- Grooved pins according to DIN EN ISO 8739 or DIN EN ISO 8744
- Slotted pins according to DIN EN ISO 8752

**IMPORTANT:**

Be aware that the linear ball bearing will be destroyed if the pin extends more than value  $t_1$  into the bearing!

The linear ball bearings LBCR 5 and LBCR 8 are without a fixation hole but are self-holding if the temperature is limited to 60 °C and mounted in housings of at least bearing length. Retaining rings are required with shorter housings. Linear plain bearings LPAR 5 and LPAR 8 are without a fixation hole.

Fig. 2

Grease fitting VN-LHC

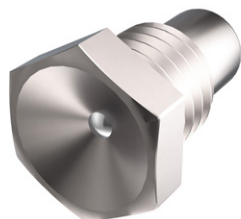
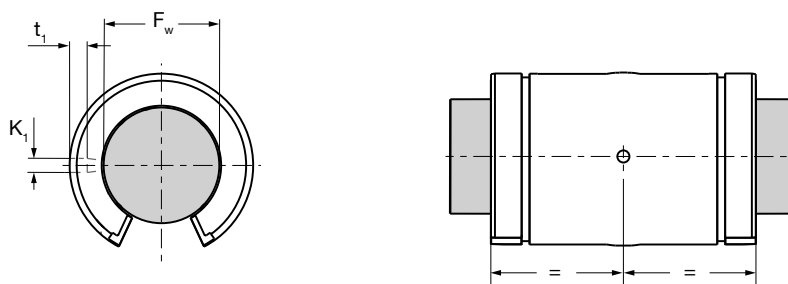


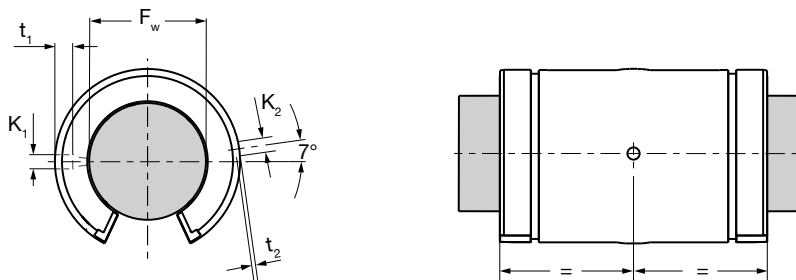


Table 1



Dimensions		Appropriate grease fitting <sup>1)</sup>		Grub screws <sup>2)</sup>		Pins <sup>3)</sup>		Pins <sup>4)</sup>		
F <sub>w</sub> mm	valid for bearing type	K1 <sup>5)</sup> mm	t <sub>1</sub>	K <sub>2</sub> <sup>6)</sup>	t <sub>2</sub>	s	-	Diameter mm	Diameter	
12	LBCR & LBCD closed design,	3,0	2,6	-	-	-	VN-LHC 20	M 4	3	3
16	LBCR & LBCD closed design, LBCT & LBCF open design	3,0	2,6	-	-	-	VN-LHC 20	M 4	3	3
20	LBCR & LBCD closed design, LBCT & LBCF open design	3,0	2,6	-	-	-	VN-LHC 20	M 4	3	3
sizes 12-20	LPAR & LPAT plain bearings	3,0	-	-	-	-	VN-LHC 20	M 4	3	3
sizes 25-40	LPAR & LPAT plain bearings	3,5	-	-	-	-	VN-LHC 40	M 5	3	3,5
sizes 50	LPAR & LPAT plain bearings	4,5	-	-	-	-	VN-LHC 50	M 6	4	4,5
sizes 60	LPAR & LPAT plain bearings	6,0	-	-	-	-	VN-LHC 80	M 8	6	6
sizes 80	LPAR & LPAT plain bearings	8,0	-	-	-	-	VN-LHC 80	M 8	8	8

Table 2

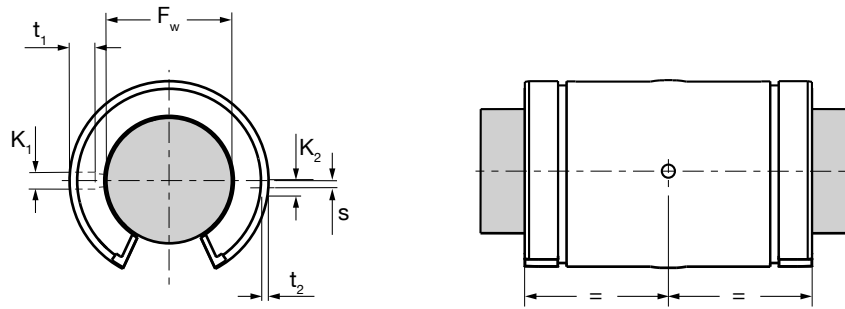


Dimensions		Appropriate grease fitting <sup>1)</sup>		Grub screws <sup>2)</sup>		Pins <sup>3)</sup>		Pins <sup>4)</sup>		
F <sub>w</sub> mm	valid for bearing type	K1 <sup>5)</sup> mm	t <sub>1</sub>	K <sub>2</sub> <sup>6)</sup>	t <sub>2</sub>	s	-	Diameter mm	Diameter	
12	LBCT & LBCF open design	3,0	2,6	3,0	1,0	-	VN-LHC 20	M 4	3	3

<sup>1)</sup> Recommendations for the design of drills to mount the grease fittings are shown in **chapter 3.3.7**  
<sup>2)</sup> Grub screws according to DIN EN 27435 or DIN EN ISO 4028.  
<sup>3)</sup> Straight pins according to DIN EN ISO 2338 or grooved pins - DIN EN ISO 8739 and DIN EN ISO 8744.  
<sup>4)</sup> Slotted pins - DIN EN ISO 8752  
<sup>5)</sup> For relubrication as well as location of linear bearings in Ewellix housings.  
<sup>6)</sup> Alternative borehole for location in specific housings from other manufacturers.

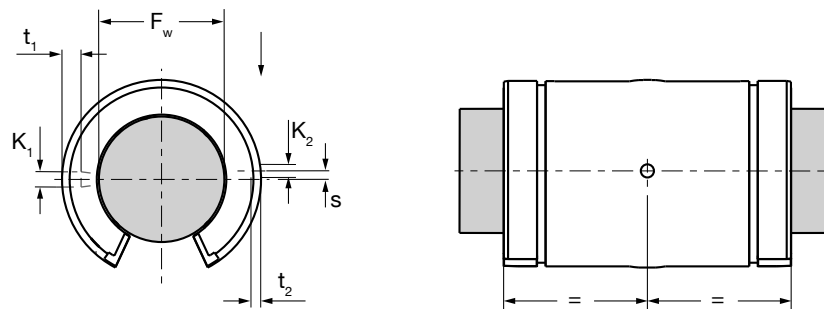


Table 3



Dimensions		Appropriate grease fitting <sup>1)</sup>	Grub screws <sup>2)</sup>	Pins <sup>3)</sup>	Pins <sup>4)</sup>				
$F_w$ mm	valid for bearing type	$K1$ <sup>5)</sup> mm	$t_1$	$K_2$ <sup>6)</sup>	$t_2$ s	-	Diameter mm	Diameter	
25	LBCR & LBCD closed design, LBCT & LBCF open design	3,5	4,5	3,0	1,4 1,5	VN-LHC 40	M 5	3	3,5

Table 4



Dimensions		Appropriate grease fitting <sup>1)</sup>	Grub screws <sup>2)</sup>	Pins <sup>3)</sup>	Pins <sup>4)</sup>				
$F_w$ mm	valid for bearing type	$K1$ <sup>5)</sup> mm	$t_1$	$K_2$ <sup>6)</sup>	$t_2$ s	-	Diameter mm	Diameter	
30	LBCR & LBCD closed design, LBCT & LBCF open design	3,5	4,5	3,0	2,3 2,0	VN-LHC 40	M 5	3	3,5
40	LBCR & LBCD closed design, LBCT & LBCF open design	3,5	4,5	3,0	2,7 1,5	VN-LHC 40	M 5	3	3,5
50	LBCR & LBCD closed design, LBCT & LBCF open design	4,5	-	5,0	- 2,5	VN-LHC 50	M 6	4	4,5
60	LBCR & LBCD closed design, LBCT & LBCF open design	6,0	-	5,0	- 2,5	VN-LHC 80	M 8	6	6
80	LBCR & LBCD closed design, LBCT & LBCF open design	8,0	-	5,0	- 2,5	VN-LHC 80	M 8	8	8

<sup>1)</sup> Recommendations for the design of drills to mount the grease fittings are shown in **chapter 3.3.7**  
<sup>2)</sup> Grub screws according to DIN EN 27435 or DIN EN ISO 4028.  
<sup>3)</sup> Straight pins according to DIN EN ISO 2338 or grooved pins - DIN EN ISO 8739 and DIN EN ISO 8744.  
<sup>4)</sup> Slotted pins - DIN EN ISO 8752  
<sup>5)</sup> For relubrication as well as location of linear bearings in Ewellix housings.  
<sup>6)</sup> Alternative borehole for location in specific housings from other manufacturers.

In the cage of the heavy duty linear ball bearings LBHT, there is not enough space for a fixation hole. For this reason, one of the lower raceway plates is drilled to take a grub screw according to DIN 27435 or DIN EN ISO 4028. Dimensions and position of the bore are indicated in **table 5**.

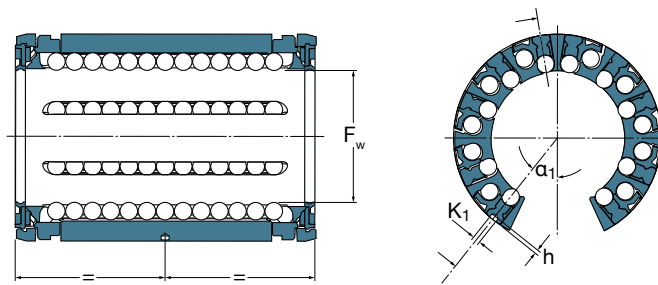
**NOTE:**

When securing LBHT bearings, care must be taken not to over-tighten these screws. If you do, excessive stress may be created onto the raceway plate, resulting in premature failure of the bearing.

If, for design reasons, none of the previously described methods can be adopted for the prevention of turning, open linear ball bearings may be retained by plates screwed to the housing, as illustrated in **figures 3** and **4** below.

Table 5

**Turning stops for LBHT linear ball bearings**

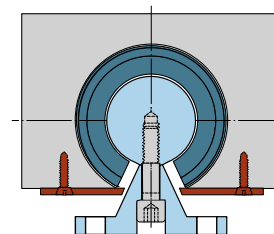
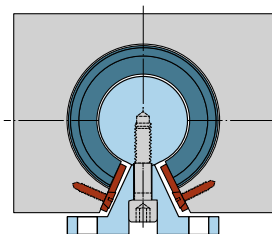


Dimensions				Appropriate grub screws <sup>1)</sup>	Designation
F <sub>w</sub> mm	K <sub>1</sub>	h	α <sub>1</sub> Deg	-	Linear ball bearing
20	2,6 ±0,05	1,3 ±0,2	47°	M4	LBHT 20
25	2,6 ±0,05	1,3 ±0,2	55° 12'	M4	LBHT 25
30	3,6 ±0,05	1,4 ±0,2	39° 15'	M5	LBHT 30
40	3,6 ±0,05	1,4 ±0,2	38° 51'	M5	LBHT 40
50	4,1 ±0,05	1,8 ±0,3	39°	M6	LBHT 50

<sup>1)</sup> Grub screws according to DIN EN 27435 or DIN EN ISO 4028

Fig. 3

Fig. 4



## 4.1.4 Axial location

The usage of grease fitting VN-LHC for bearing fixation is recommended and most applications with linear bearings need axial and rotational fixation of the bearing, e.g. open type linear ball bearings or if a closed bearing has to be mounted with defined orientation (↳ **chapter 4.1.3**). For some applications, it is sufficient to fix the bearing in axial direction only. The main methods for axial location are described below.

Axial location using retaining rings (↳ **fig. 5** and **fig. 6**) takes little space, enables fast mounting and dismounting and simplifies the machining of the associated components. Standard linear ball bearings and plain bearings are equipped with two grooves for retaining rings on the outer diameter. Use retaining rings according to DIN 471 to locate the bearing as shown in **figure 6**. It's important to know that the spring force of the retaining ring slightly preloads the balls via the loosely held raceway plates. The radial clearance between the outer surface of the raceway plates and the housing bore remains.

Additionally, end plates, covers (↳ **fig. 7**) or retaining plates (↳ **fig. 8**) can be screwed to the housing to provide axial location for the bearing.

It is also possible to axially locate the bearing on a housing shoulder (↳ **fig. 9**), but please consider the outer radius on the bearing and the corner radius R in the housing.

In each case, ensure that a slight amount of clearance in axial direction, between mounting surfaces and bearing, remains!

Fig. 5

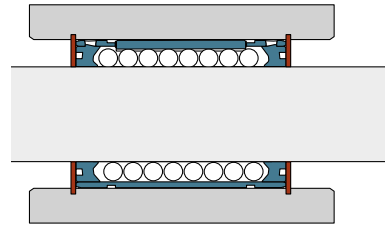


Fig. 6

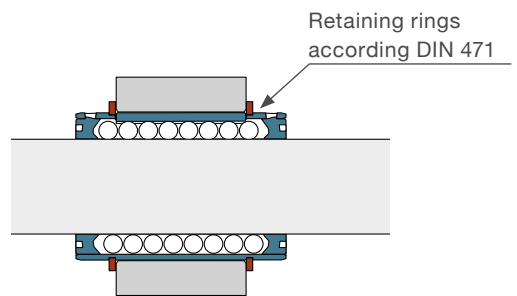


Fig. 7

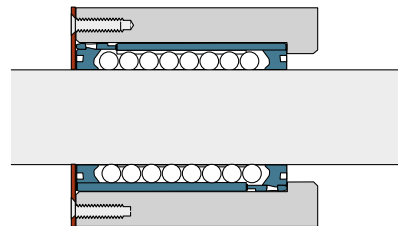


Fig. 8

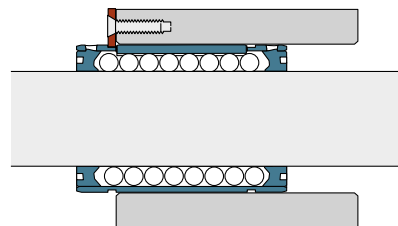
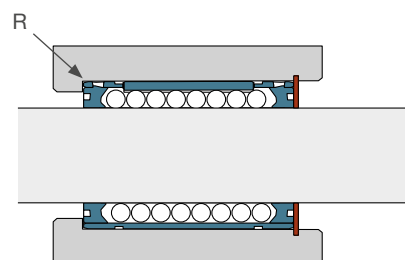


Fig. 9



## 4.1.5 Sealing

All Ewellix linear ball bearings can be ordered with double lip seals. Generally, the seals for linear ball bearings have to prevent the ingress of solid contamination and moisture and retain the lubricant in the bearing to release the full performance of the bearing.

Linear bearings that are used in harsh environments might need additional protection. It is state of the art to use shaft seals as additional protection. A housing that incorporates additional shaft seals only needs to be twice the width of the shaft seal longer. Ewellix offers a certain range of shaft seals (↳ **chapter 3.1.3**). Further dimensions are commercially available. Shaft seals can be integrated into the housing cover (↳ **fig. 10**) or can be placed directly into the housing bore (↳ **fig. 11**).

As the environmental conditions can differ a lot, each installation must be considered individually and the right sealing type has to be found. Various factors have to be taken into account when selecting the appropriate seal for a linear bearing, for instance the design, available space, type and severity of the contaminants, cost aspects, as well as the maximum permissible friction. For linear ball bearings with self-aligning capability, make sure the seal is always in contact with the shaft.

## 4.1.6 Requirements on precision shafts

Shafts have an important role in a linear bearing system. The hardness and hardness depth have a direct impact on the rating life. The tolerance of the shaft diameter influences the operating clearance, that's why tolerances h6 or h7 are generally recommended. The dimensional and form accuracy of precision shafts are important factors for the accuracy of a linear guiding system. The main characteristics are broadly covered by ISO 13012:

- **Roundness:** Excessive deviation from roundness can lead to uneven load distribution in a linear ball bearing that may result in overloading of individual raceway plates.
- **Cylindricity:** This factor is of particular importance in determining the accuracy of guidance of a linear ball bearing, due to momentary distortion of the outer surface of the shaft.
- **Straightness:** The straightness of shafts in an unloaded condition is of secondary importance since the deflection of unsupported shafts or the load on supported shafts are of greater significance.

In **chapter 3.7** of this catalogue, all specifications of Ewellix precision shafts are defined in detail. The values there can guide you to determine your own shaft, as they are the minimum requirements that shafts for linear guiding systems have to fulfil.

Generally, shaft ends should be rounded or chamfered with an angle of approximately 20°. This facilitates mounting and permits the shaft to be inserted without damaging the balls or seals of the bearing.

Fig. 10

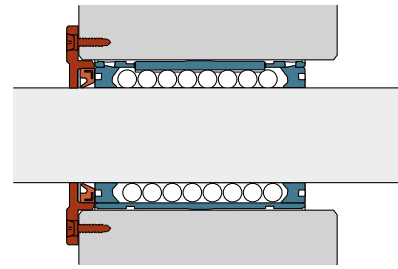
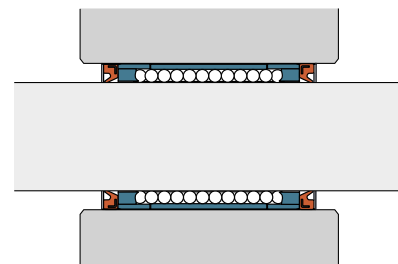
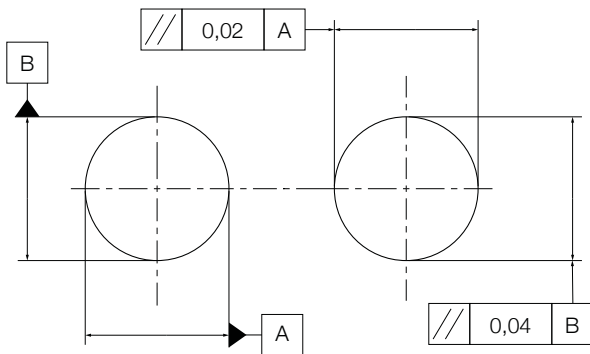


Fig. 11



## 4.1.7 Mounting surfaces and shaft alignment

For smooth running of the linear slide system and to ensure that no additional loads that may reduce the rating life act on the bearing, the parallelism between two shafts should be as good as possible. The maximum deviations are shown in the following illustration.



This value is valid no matter if supported or unsupported shafts are used. It should also guide you when defining the mounting surfaces for shaft supports or shaft blocks.

Shafts with axial threads (↳ [chapter 3.7.7](#)) enable fast mounting and easy alignment.

## 4.2 Mounting of linear bearings

Great care and attention to cleanliness are essential when mounting Ewellix linear bearings to obtain optimum performance and to avoid premature bearing failure. Ewellix linear ball bearings are precision products and should be handled appropriately. Above all, the correct installation procedures should be followed and the appropriate tools used at all times.

### 4.2.1 Preparation

Mounting should be carried out in a dry and clean surrounding. Before mounting the bearings, all the necessary parts, tools and equipment should be at hand. All parts of the linear guide (housing, shaft, etc.) should be carefully cleaned and deburred if necessary and the accuracy of form and dimensions checked against the specifications. The bearings will only perform satisfactorily if the prescribed tolerances are adhered to. The bearings should not be removed from their original packaging until immediately before mounting, in order to avoid contamination. Normally, the preservative with which new bearings are coated before leaving the factory should not be removed. Only for compact linear ball bearings and their self-holding functionality is it necessary to wipe the preservative off the outer surface. Where special greases are used which are not compatible with the preservative, the bearings must be carefully washed and dried in order to avoid any detrimental effect on the lubricating properties of the grease.

### 4.2.2 Mounting

Ewellix linear ball bearings are easy to mount in a chamfered housing bore and little force is required. Small to medium diameter linear ball bearings can even be inserted by hand. If more force is needed to mount the bearings, the use of a mechanical hand press is recommended. When standard linear ball bearings are to be mounted and secured against turning, e.g. by the use of a grease fitting, care should be taken that the lube port of the bearing, that acts also as attachment hole, is aligned with the hole in the housing.

**Figure 14** shows perfect alignment of the indicator for lubrication port position and the grease fitting.

It is advisable to use a mandrel between the press and the linear ball bearing. The mandrel, preferably plastic, should be designed to provide guidance to the bearing and to give complete support to the bearing's end face so that seal damage is avoided. If the bearing is recessed in the housing, the mandrel may have the form shown in **figure 12**, whereas the design in **figure 13** should be used when the bearing has to be flush with the housing. Hammer blows to the linear ball bearing are to be avoided at all times as these would damage the seals and the cage.

Fig. 12

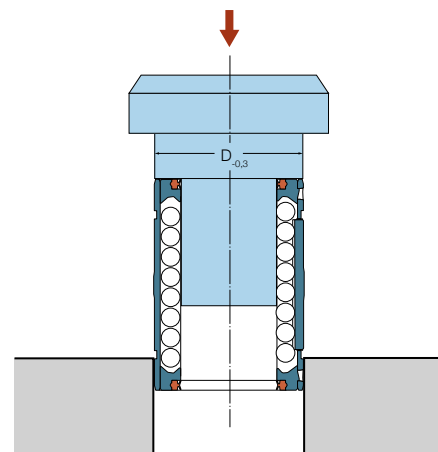
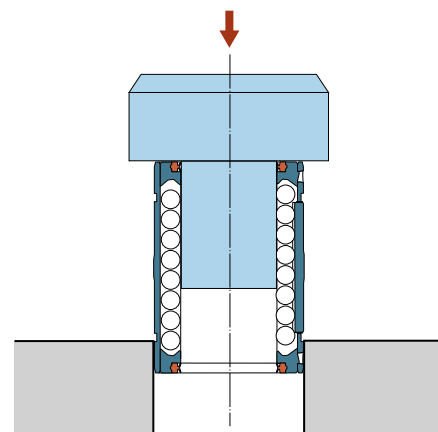


Fig. 13



Insert the shafts carefully into the lubricated bearings. Find more details about lubrication in **chapter 4.3**. Don't damage the linear bearing or the seal and make sure that the shafts are aligned with the right parallelism (↳ **chapter 4.1.7**). For easier alignment, most Ewellix linear bearing units and shaft blocks feature a reference side with tight tolerances (↳ **fig. 14** and **15**).

Screw connections have to be state of the art and the dimensioning has to be done by the customer. Lateral sliding of any component has to be prevented, e.g. by using a stop edge or retaining strip.

### 4.2.3 Mounting of linear plain bearings

To facilitate mounting, the shaft ends and the housing bore should be chamfered to an angle of approximately 20°. Ensure that there are no sharp edges or burrs on the shaft that might scratch the sliding surfaces of the bearing.

When mounting a linear plain bearing, by hand or mechanical hand press, the use of a mandrel is recommended as in the case of linear ball bearings (↳ **chapter 4.2.2**). Light oiling or greasing of the bearing's outer diameter allows easier insertion.

**NOTE:**

Even in applications for which no permanent lubrication is intended, it is advisable to apply some lubricant into the bearing directly when mounting and during the running in period. This helps to lower the coefficient of friction during running in and to increase the service life of the bearing.

### 4.2.4 Adjustment of operating clearance

The operating clearance of all single linear units in slotted and open design is set by an adjustment screw in the housing. For zero operating clearance the adjustment screw should be tightened until a slight resistance can be felt when either the shaft or the unit is turned by hand. Preload of linear bearings can be applied using the same method, but with a calibrating shaft whose diameter is reduced by the desired preload. After mounting on the shaft, preloaded or zero-clearance linear bearings should not be rotated as this might lead to markings or scratches. Secure the adjustment screw, for example with threadlocker.

**NOTE:**

The linear unit must always be on a shaft and without external loads when adjusting the clearance.

Fig. 14

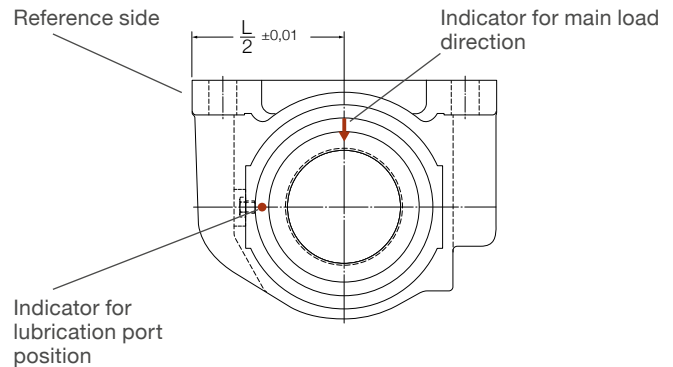
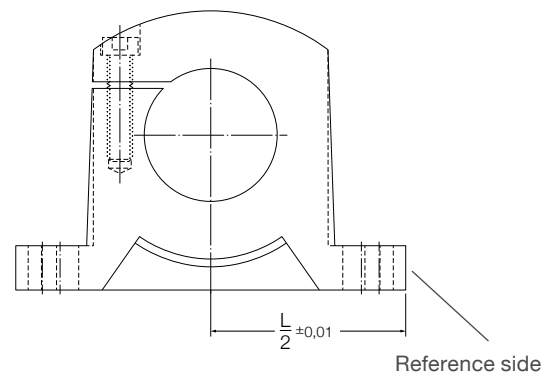


Fig. 15





# Lubrication

The appropriate type and amount of lubricant is required for a linear bearing to achieve its optimum performance. To reduce wear, the lubricant prevents direct metal-to-metal contact between the rolling elements and the raceway plates. In addition, the lubricant protects the linear bearing and shaft from corrosion. Usually, linear bearings are operated with grease as lubricant.

## 4.2.5 Grease lubrication

Under normal operating conditions, linear bearings should be lubricated with grease. The advantage of grease is that it is more easily retained in the bearing, which is particularly important when the axis of travel is inclined or vertical. Moreover, it contributes to sealing the bearing against the ingress of liquid contaminants or humidity.

### Base oil viscosity

The viscosity of the lubricating oil in a grease is key to the formation of the hydrodynamic film that separates the rolling elements from the raceway plates.

In general, the viscosity of lubricating oils is based on the flow rate at 40 °C. This value also applies to the mineral base oil contained in lubricating greases.

The base oils of commercially available rolling bearing greases have viscosity values between 15 and 500 mm<sup>2</sup>/s (at 40 °C). Greases with higher base oil viscosities often release the oil too slowly to sufficiently lubricate bearings. Find more details about requisite viscosity and factor for operating conditions,  $c_2$ , in **chapter 2.2.3**.

### Consistency class

Lubricating greases are divided into various consistency classes according to a scale from the National Institute of Grease Lubrication (NLGI). These are also reflected in DIN 51 818 and DIN 51 825.

Greases with a metallic soap thickener with a consistency of 2 or 3 on the NLGI scale are particularly suitable for use with Ewellix linear bearings. The grease consistency should not vary too much with changing operating temperatures or stress levels. Greases that soften at higher temperatures can leak from the bearing position, while greases that get stiffer at lower temperatures can impede the operation of the linear guiding system.

Specific requirements are placed on the lubricating grease's purity, composition and compatibility if the grease is to be used in special applications, for instance in the food sector, medical engineering, etc. In such cases, criteria should be further specified for the lubricant in addition to viscosity and consistency class.

### Temperature range

The temperature range over which a lubricant can be used depends largely on the type of base oil and thickener as well as the additives.

The low temperature limit, the lowest temperature at which the grease enables the bearing to be started up without difficulty, is largely determined by the type of base oil and its viscosity. The high temperature limit is determined by the type of thickener and its dropping point. The dropping point is the temperature at which a grease changes its consistency and becomes a fluid.

**NOTE:** Grease will age with increasing rapidity at higher operating temperatures. The resulting by-products have a detrimental effect on the grease's lubrication properties and conditions in the rolling contact zone.

Lubricating greases with synthetic base oils can be used both at higher and lower temperatures compared to lubricants with a mineral oil base.

### Corrosion inhibiting additives in lubricants

Lubricants typically contain additives to inhibit corrosion. In addition, the type of thickener is crucially important in this regard. Lithium-base and calcium-soap greases provide excellent corrosion protection properties. They are also resistant to water wash-out.

In applications where corrosion protection is a key operational parameter, Ewellix recommends stainless linear ball bearings (suffix /HV6) and stainless steel or chrome-plated shafts.

## 4.2.6 Delivery condition from factory

Ewellix linear ball bearings and units for shaft diameter 8 mm and larger are factory pre-lubricated. This saves assembly time and maintenance effort. The linear ball bearings are lubricated with the high-performance grease LGEP 2 from SKF that is suitable for a wide range of industrial and automotive applications. The grease is based on lithium soap and mineral oil, whereas the extreme pressure additives provide a good anti-wear protection and corrosion resistance (→ **table 6**).

Special greases for food or clean room environments are available on request. Linear ball bearings without factory pre-lubrication can be ordered, too. Before mounting non pre-greased linear bearings, they have to be suitably lubricated (→ **chapter 4.3.3**). When using other lubricants, make sure they have the right properties and are compatible with the bearing materials and the preservative.

Ewellix linear ball bearings are always protected with a corrosion inhibiting preservative for transport and storage. This preservative is compatible with LGEP 2 grease but is not food-grade.

**NOTE:** Linear ball bearings LBBR 6 and LBCR 5 are factory pre-lubricated with oil (Paraliq P460 from Klueber), by default. LBBR 3, 4 and 5 are without lubricant by default but are also protected with a preservative for transport and storage as the other bearings.

Table 6

Properties of grease LGEP 2	
Thickener	Li
Base oil	Mineral oil
Operating temperature, (steady state)	-20 up to +110°C
Kinematic viscosity of base oil	200 mm <sup>2</sup> /s
Consistency class	NLGI 2
Additive	EP additives for long service life

## 4.2.7 Initial lubrication

Initial lubrication is not required since Ewellix linear ball bearings are delivered factory pre-lubricated and ready to install unless specified otherwise. If for any reason the bearing is not yet lubricated, make sure it is initially greased prior to mounting and that the grease is spread over all ball rows and recirculations. The initial grease fill should be applied three times according to the steps below:

1. Grease each linear bearing with the quantity described in **chapter 4.3.4**.
2. Move the linear bearing several times backwards and forwards with stroke longer than bearing length.
3. Repeat steps 1 and 2, twice more.
4. Check if a lubricating film is visible on the shaft.

## 4.2.8 Relubrication

The grease quantity for relubrication can be determined using the following formula:

$$G_p = F_w \cdot C \cdot \text{No. of rows} \cdot \text{const}_1$$

where

- $G_p$  grease quantity, g
- $F_w$  nominal inner bearing diameter, mm
- $C$  width of the linear ball bearing, mm
- No. of rows number of ball rows
- $\text{const}_1$  constant 1, see table below

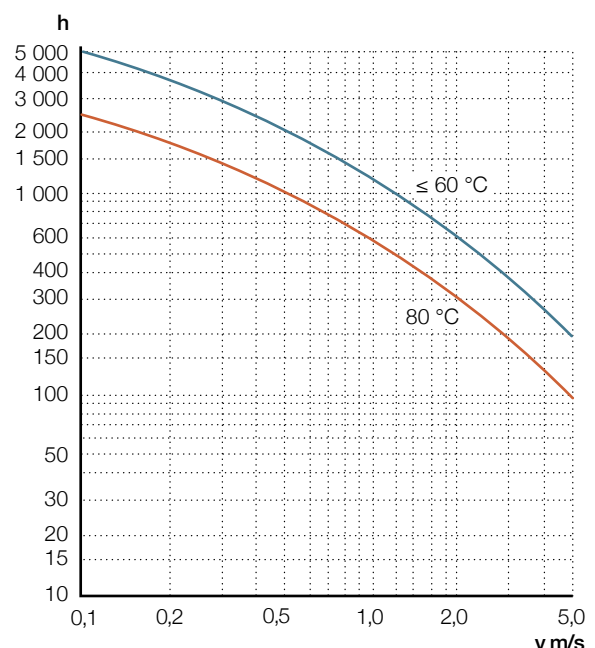
Table 7

Type	Size	$\text{const}_1$
LBBR	8 - 50	0,00003
LBCR, LBCD	8 - 40	0,00003
	50 - 80	0,00009
LBCT, LBCF	12 - 40	0,000025
	50 - 80	0,000075
LBHT 20 - 50	20 - 50	0,000025

Relubrication should always be done at a time when lubrication conditions inside the bearing are still satisfactory. Relubrication intervals for linear ball bearings depend on many factors. Primary factors are average running speed, load, operating temperature, shaft length and grease quality. A suitable relubrication interval has to be determined by tests under real conditions.

The following figure shows the dependency on running speed and temperature onto the relubrication interval. The guideline values shown below represent a fixed installation under normal load.

Relubrication interval



## 4.3 Maintenance

### 4.3.1 Preventative maintenance

To avoid dirt from adhering to the shafts, they should be cleaned regularly with a cleaning stroke. Ewellix recommends a cleaning stroke over the entire length of the shafts twice a day or at least after eight hours of operation. That wipes away dirt particles and spreads a new lubricant film onto the shafts for continuous corrosion protection.

### 4.3.2 Repairs

If the linear bearing system has reached the end of its service life and has to be replaced, Ewellix recommends replacing the whole system, meaning shafts and bearings.

Sometimes it's possible to change a single component only, but it's often more economical to replace everything considering time for assembly and disassembly.

When ordering a spare bearing, make sure to mention the main dimensions, including shaft diameter, housing bore diameter, bearing width and type of sealing. Alternatively, find the suitable replacement in **chapter 3** on your own and use the ordering key as indicated.

For ordering a spare precision shaft, you need to provide the diameter, the length, the end machining and, if the shaft is supported, the details about lateral threads and J dimensions. For customised shafts, please send a drawing for re-ordering.

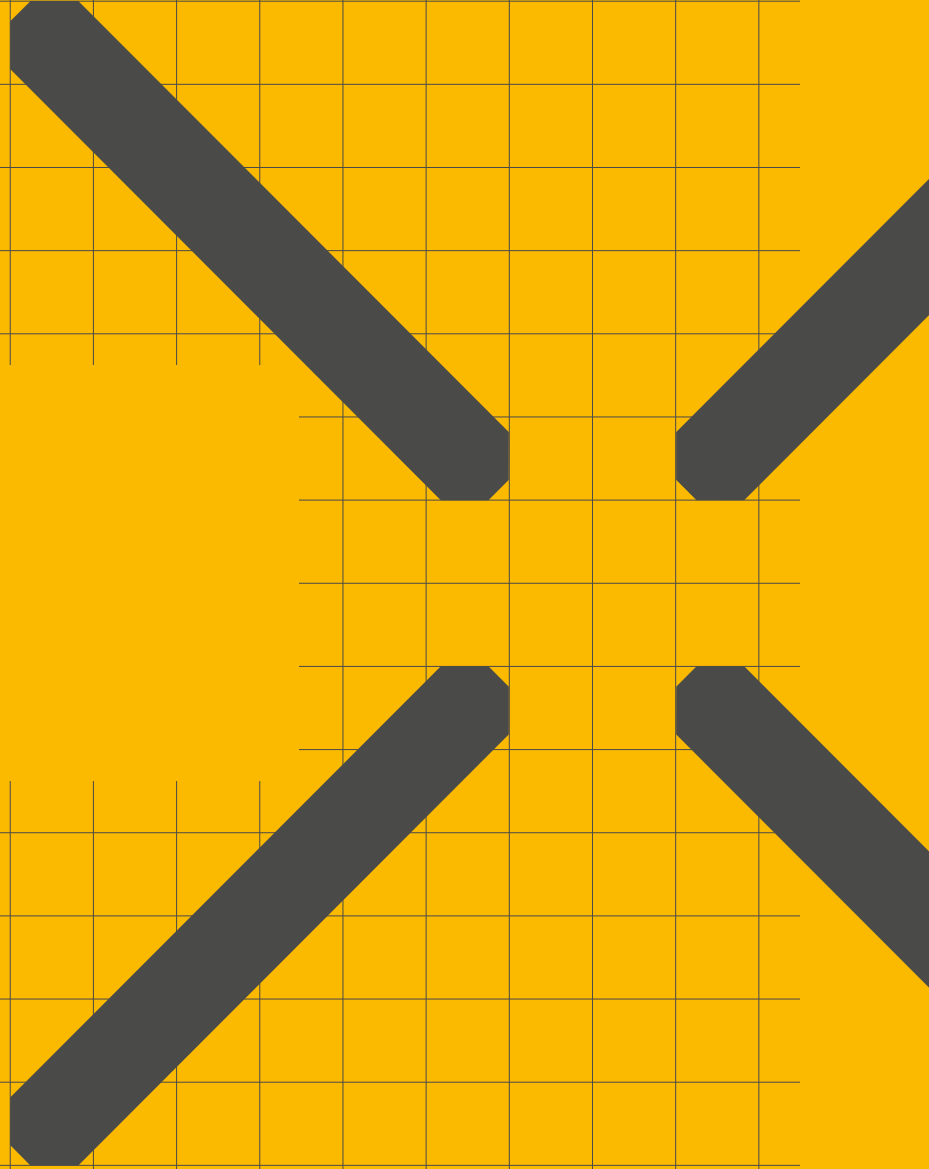
### 4.3.3 Shipping and storage

Linear ball bearings should be stored in a cool and dry indoor area and inside its original packing, which should be kept closed until the bearing is needed for use. The indoor temperature should not exceed 30 °C (86 °F) and should remain above 0 °C (32 °F). Make sure the relative humidity of the storage area does not exceed 60 %. Do not store directly near a heat source and avoid exposure to direct sunlight.

The bearings are normally coated with a rust inhibiting preservative before packing and can be stored for up to four years in their original unbroken packaging. It is possible that the lubricating properties of the grease inside the bearing will deteriorate if stored for a longer time. In such case the old grease has to be replaced by the necessary amount of fresh grease before usage. Bearings with seals, when stored for longer periods, may be found to have a higher initial starting friction than new bearings.

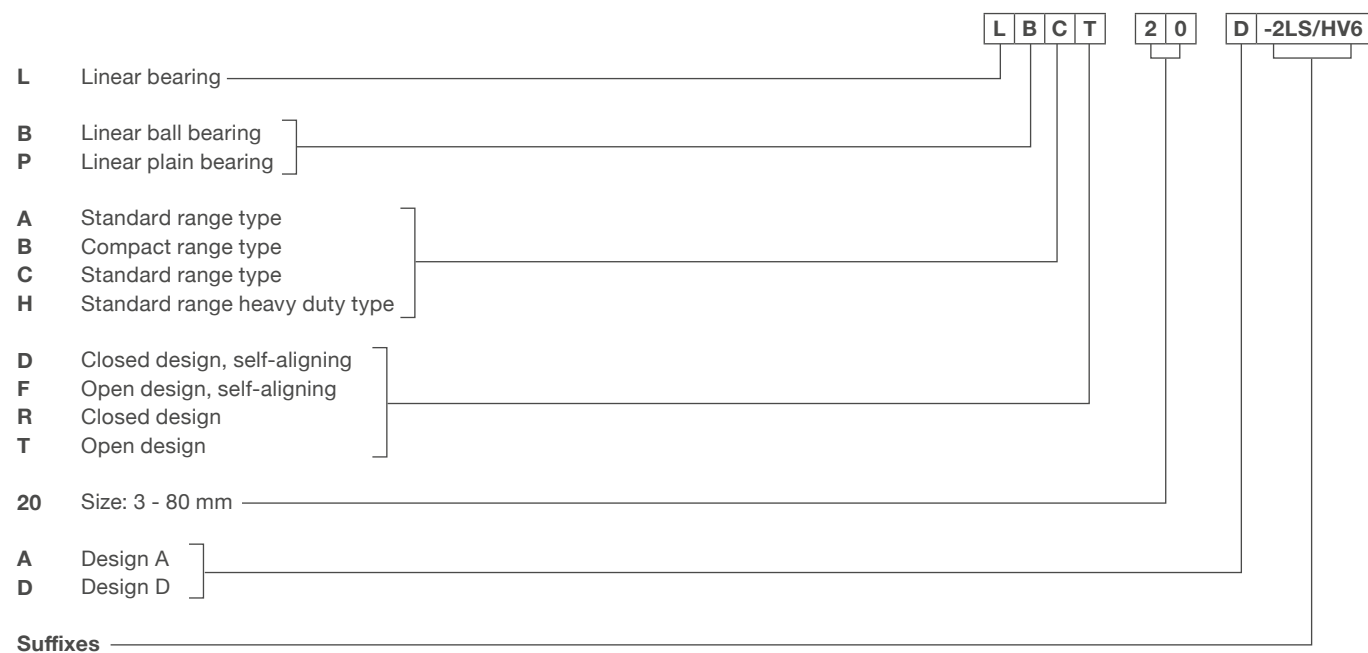
5

Ordering key

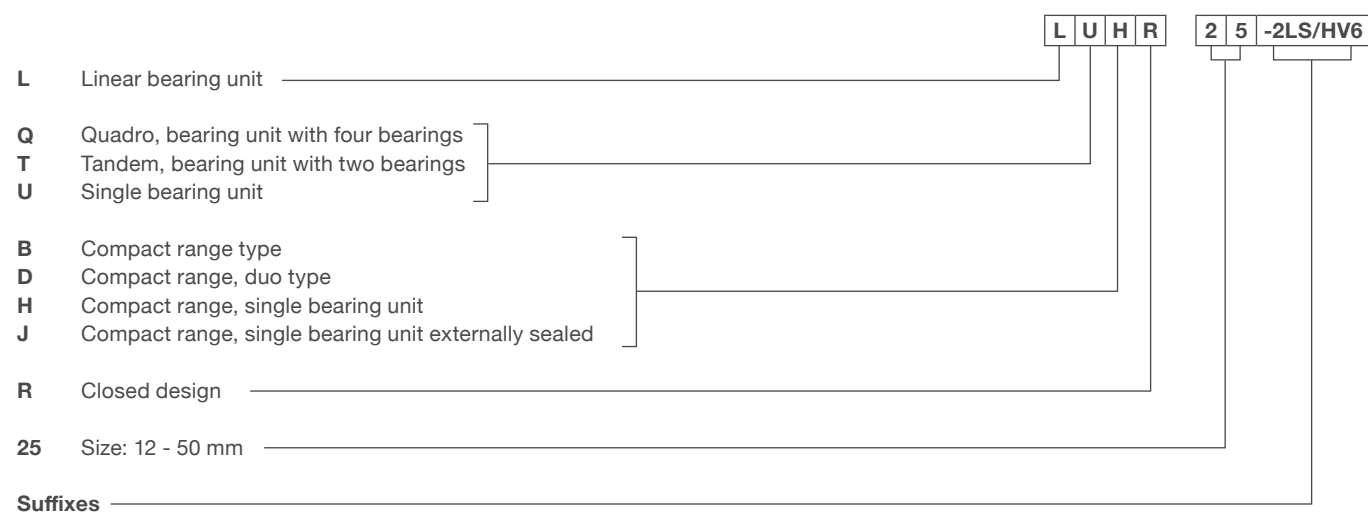


# Ordering key

## Linear bearings



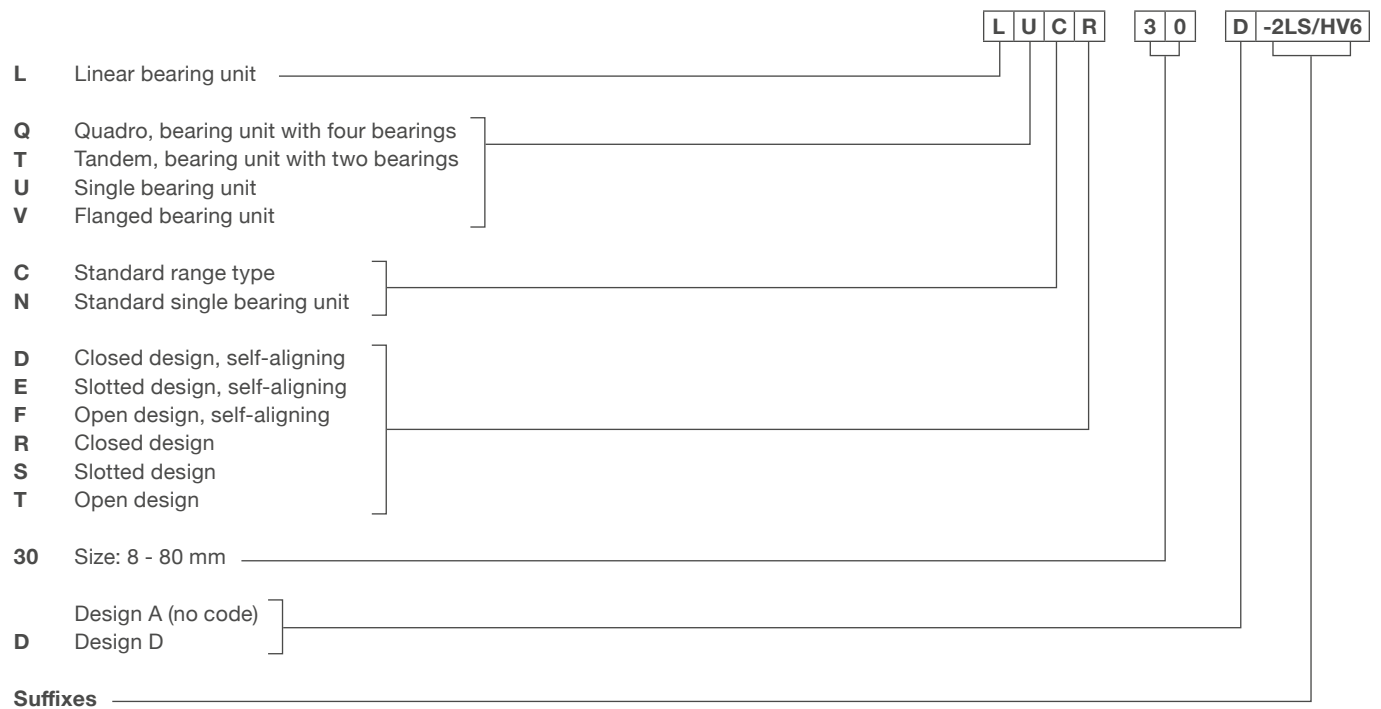
## Compact linear bearing units



**REMARKS:**

- An overview of available products is shown in **chapter 1.3.2.**
- Some combinations of ordering key letters are not possible.

# Standard linear bearing units



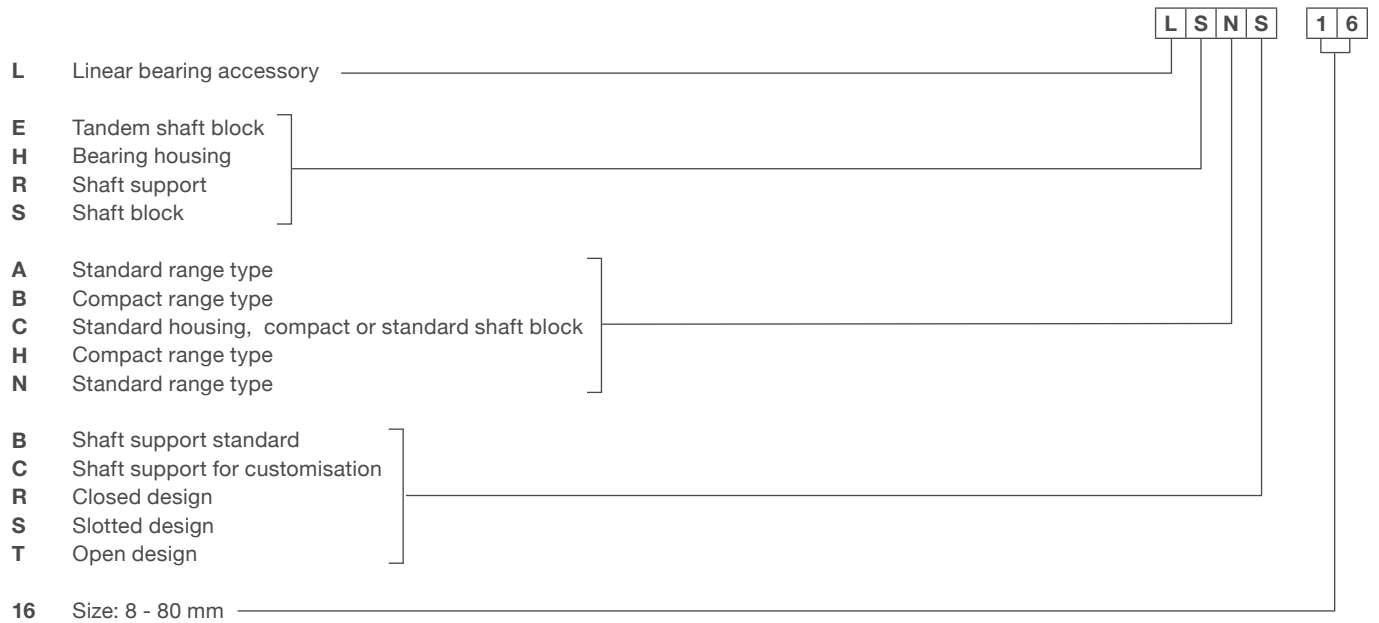
## Suffixes

- 2LS** Linear bearing or units sealed on both sides
- LS** Linear bearing or units sealed on one side
- BH** Unit with heavy duty bearing
- /HV6** Stainless steel variant
- PA** Unit with standard plain bearing
- PB** Unit with compact plain bearing

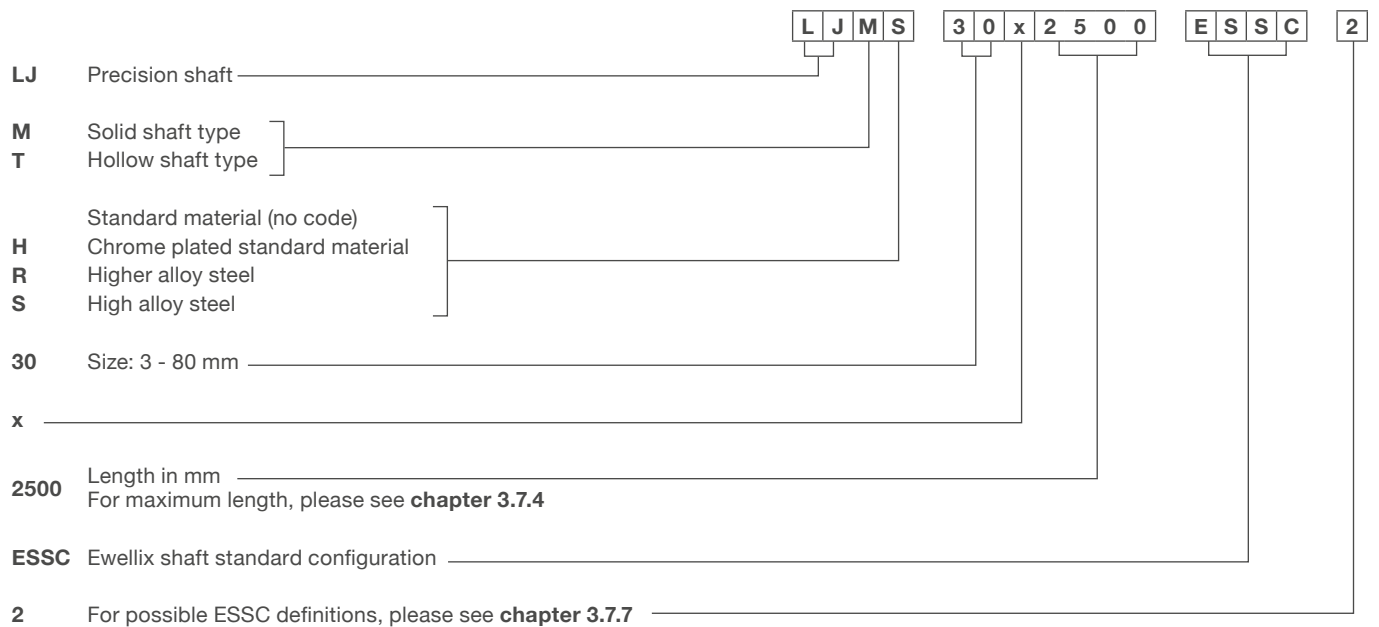
**REMARKS:**

- An overview of available products is shown in **chapter 1.3.2.**
- Some combinations of ordering key letters are not possible.

## Linear bearing accessories



## Precision shafts

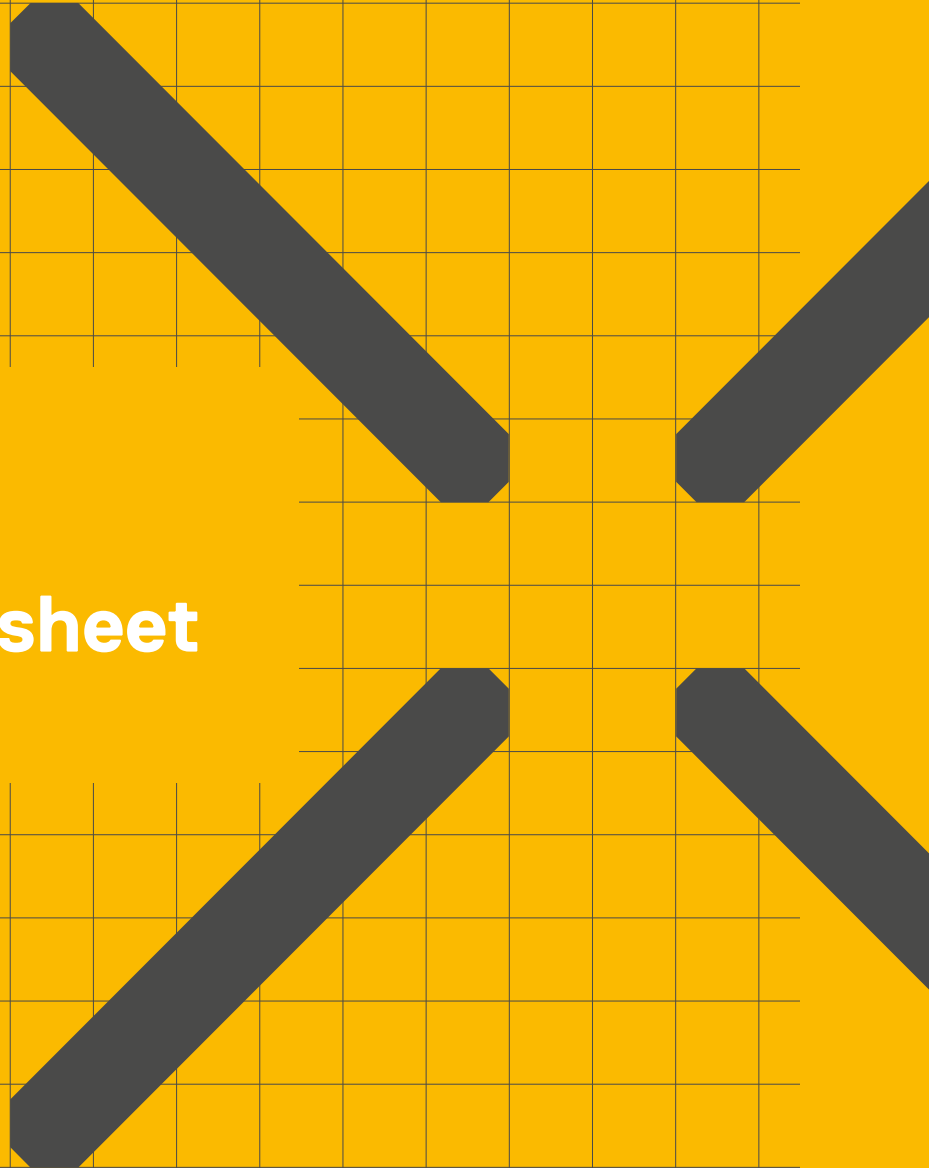


**REMARKS:**

- An overview of available products is shown in **chapter 1.3.2.**
- Some combinations of ordering key letters are not possible.

6

**Customer  
specification sheet**





### Specification sheet – Linear Ball bearing

Please complete the form with all available information and send it to your Ewellix representative or authorized distributor for product selection.

Ewellix contact	Date
-----------------	------

### General information

Customer			Contact	
Company			Contact name	
Address 1			Job title	
Address 2			Department	
Post code / Zip	City	State	Phone (including country code)	Mobile (including country code)
Country			Mail	

Project title
---------------

#### Reason for request

Current product / brand	Description	
<input type="radio"/> Replacement	<input type="radio"/> New design	<input type="radio"/> Other

#### Application / Industry

<input type="radio"/> Factory automation	<input type="radio"/> Food and beverage	<input type="radio"/> Machine tools	Description
<input type="radio"/> Medical	<input type="radio"/> Semiconductor	<input type="radio"/> Other	

#### Export control and Ewellix policy (mandatory to mark)

<input type="radio"/> The application is not subsidiary or part of industry of national defence and/or nuclear (also not with details of the function). The application is civil.
---

### Commercial information

#### General

<input type="radio"/> One shot business	Quantity, pcs	Batch size, pcs	Start of supply, YYYY MM DD	Target price / each	Currency
<input type="radio"/> Yearly repeating business					

### Application description

**Specification sheet – Linear Ball bearing**

<b>Stroke</b> mm	<b>Shaft length</b> mm	<b>Center distance between</b> bearings, c mm shafts, d mm	<b>or Short part dimensions</b> Length mm Width mm	<b>Guiding system</b> Maximum height mm <input type="radio"/> No constraints
---------------------	---------------------------	--	--	--

<b>Required service life distance or time</b> (fill in all fields)				<b>Required static safety</b> (in accordance to your business and application)
Distance km	Total time h	Period of one cycle s	Stroke of one cycle mm	

<b>Maximum speed</b> 1) m/s	<b>Maximum acceleration</b> 1) m/s <sup>2</sup>	<b>Rigidity of guiding system</b> N/μm <input type="radio"/> No specific requirements	<b>Running accuracy of guiding system</b> Parallelism in height μm Parallelism in sideward direction μm
--------------------------------	--	---	---

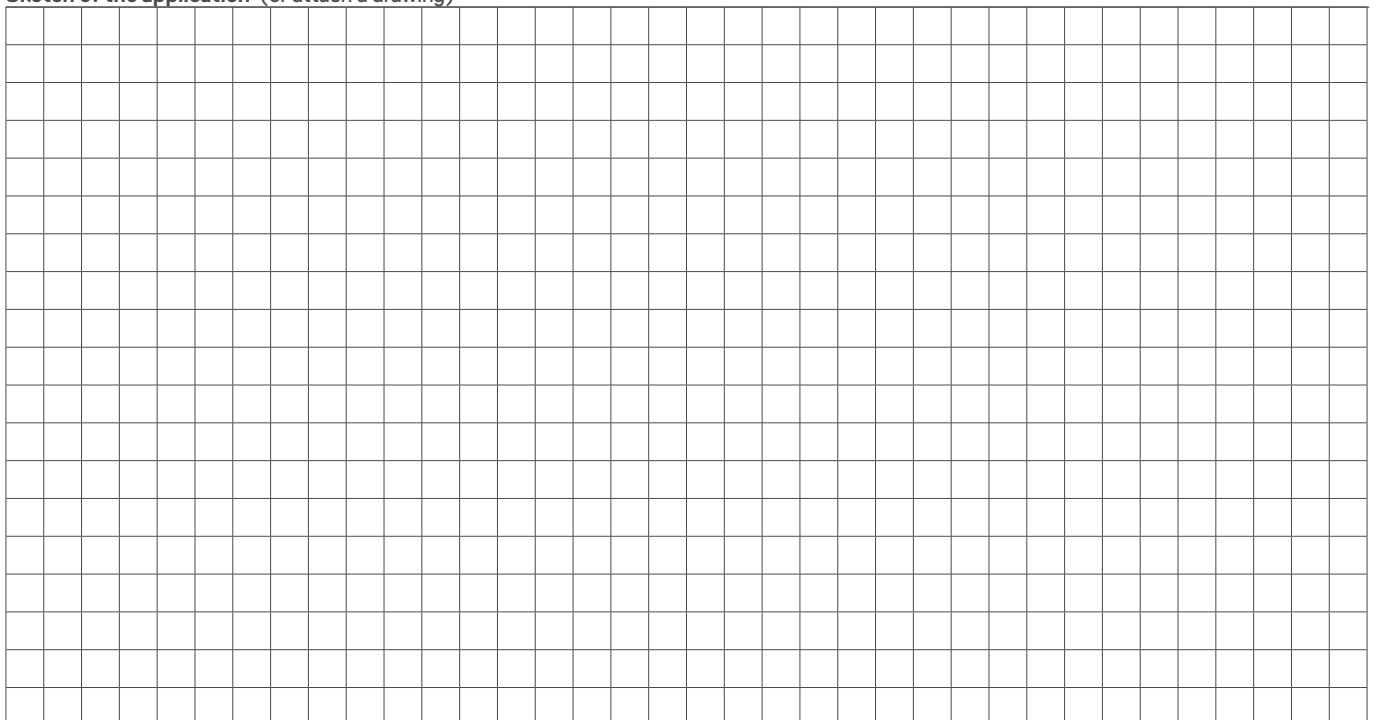
1) Here the maximum values. Enter load phase specific values in table "External loads and load phases"

<b>Environment</b>	
Presence of dust, dirt or fluids <input type="radio"/> Clean environment, e.g. laboratory <input type="radio"/> Standard industrial environment <input type="radio"/> Dirty environment, e.g. milling machine  <input type="radio"/> Humid or corrosive environment If yes, please describe:	Requirements on friction <input type="radio"/> Lowest possible friction <input type="radio"/> Standard friction <input type="radio"/> No requirement  Preferred material <input type="radio"/> No preference (standard) <input type="radio"/> Stainless steel balls and raceways ( /HV6) <input type="radio"/> Stainless steel shaft <input type="radio"/> Chrome plated shaft  Preferred sealing variant <input type="radio"/> With shields <input type="radio"/> With 1 double lip seal ( -LS) <input type="radio"/> With 2 double lip seals ( -2LS) <input type="radio"/> Additional sealing

<b>Temperature</b> [°C] Minimum Operating Maximum	<input type="radio"/> Shock loads or vibrations If yes, please describe:
--	---

<b>Lubricant</b> <input type="radio"/> Standard pre-lubrication by Ewellix, as stated in the catalogue. <input type="radio"/> Other Please specify
--

**Sketch of the application** (or attach a drawing)



## Product details

### Product designation (if already known)

#### Range

- Compact range  
 Standard range

#### Bearing type

- Linear ball bearing  
 Linear plain bearing

#### Bearing design

- Closed design  
 Open design (for supported shafts)

- Rigid (permissible shaft deflection without reduction  $\pm 5'$  of arc)  
 Self-aligning (permissible shaft deflection  $\pm 30'$  of arc)

### Needed accessories (for details see Ewellix publication Linear ball bearings and units)

#### Shaft

Designation

LJ ...

Length

mm

Shafting standard

ESSC ...

#### Housing

Designation

#### Single shaft block

Designation

LS ...

#### Tandem shaft block

Designation

LE ...

### Linear ball bearings mounted as a complete system

#### System

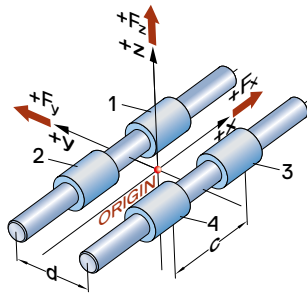
Designation

LZ ...

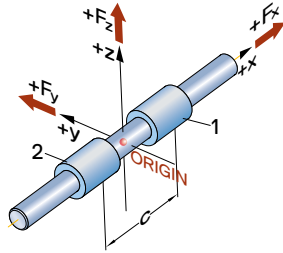
#### System with drive, e.g. ball screw

Specification sheet – Linear Ball bearing

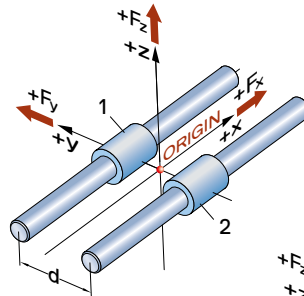
Input for dimensioning calculation



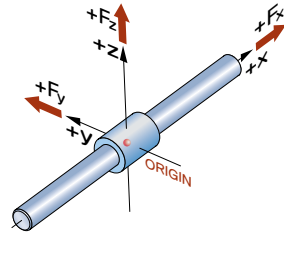
Config 24



Config 12



Config 22



Config 11

- No preference
- Other

If yes, please describe:

Moving direction (set coordinate system accordingly)

- Horizontal
- Vertical
- Other

Please specify:

External loads and load phases

Forces in N, Lever arms in mm measured from defined origin (see graphics above). If the application has more than 3 load phases, please copy this page.

Load phase 1			
Stroke	mm		
Acceleration	mm/s <sup>2</sup>		
Speed	m/s		
	Lever arms in		
Force F <sub>x</sub>	x	y	z
Force F <sub>y</sub>	x	y	z
Force F <sub>z</sub>	x	y	z

Load phase 2			
Stroke	mm		
Acceleration	mm/s <sup>2</sup>		
Speed	m/s		
	Lever arms in		
Force F <sub>x</sub>	x	y	z
Force F <sub>y</sub>	x	y	z
Force F <sub>z</sub>	x	y	z

Load phase 3			
Stroke	mm		
Acceleration	mm/s <sup>2</sup>		
Speed	m/s		
	Lever arms in		
Force F <sub>x</sub>	x	y	z
Force F <sub>y</sub>	x	y	z
Force F <sub>z</sub>	x	y	z





**ewellix.com**

© Ewellix

All contents of this publication are the property of Ewellix, and may not be reproduced or given to third parties (even extracts) without permission. Although great care has been taken in the production of this catalog, Ewellix does not take any responsibility for damage or other loss resulting from omissions or typographical errors. The photo may differ slightly in appearance from the actual product. Due to continuous improvements being made in our products, the product's appearance and specifications are subject to change without notice.

**PUB NUM IL-06013/8-EN-September 2024**

Certain image(s) used under license from Shutterstock.com.  
Schaeffler and the Schaeffler logo are trademarks of the Schaeffler Group.