

EWELLIX

A Schaeffler Company

INSTALLATION, OPERATION AND MAINTENANCE MANUAL

CPMA and CPMB

Lifting column

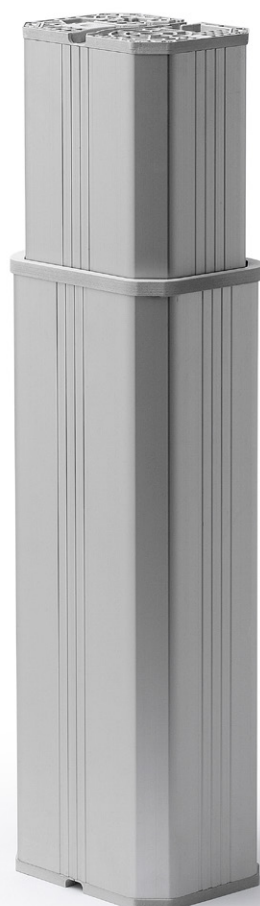

Contents

1.0 General information	4	6.0 Installation and first operation	20
1.1 Information in this manual	4	6.1 Installation location	21
1.2 Explanation of symbols and signal words	4	6.2 Inspections prior to initial operation	21
1.3 Limitation of liability.....	5	6.3 Installation.....	22
1.4 Copyright.....	5	6.4 Connection to power supply.....	24
1.5 Spare parts.....	5	6.5 Requirements concerning installation of accessories	24
1.6 Warranty terms.....	5	6.6 Initial start-up.....	26
1.7 Customer service.....	5	7.0 Operation	27
2.0 Safety	6	7.1 Safety	27
2.1 Use	6	7.2 Turn on.....	27
2.2 Responsibility of the owner and processor.....	6	7.3 Turn off.....	27
2.3 Personnel requirements.....	7	7.4 Action before use.....	27
2.4 Specific dangers.....	7	7.5 Action during operation.....	27
2.5 Safety equipment	8	7.6 Emergency disengagement	28
2.6 Safeguard against restart	8	7.7 Shut-down	28
2.7 Modifications of device.....	8	8.0 Maintenance	29
2.8 Manufacturer's declaration of EMC compliance	9	8.1 Maintenance plan	29
3.0 Technical data	13	8.2 Maintenance work	29
3.1 Ambient conditions.....	13	8.3 Measures following maintenance.....	30
3.2 Product label.....	13	9.0 Malfunctions	30
4.0 Structure and function	14	9.1 Malfunction table	31
4.1 Overview.....	14	9.2 Start of operation after malfunction repair.....	32
4.2 Brief description	15	10.0 Dismantling	33
4.3 Special features.....	15	10.1 Dismantling.....	33
4.4 Requirements for third party power supply (mandatory for lifting columns CPMA and CPMB 24 V DC in medical applications)	16	10.2 Disposal.....	33
4.5 Connections	16	11.0 Appendix	34
4.6 Operating elements	16	11.1 Technical data	34
4.7 Options	16	11.2 Plans and diagrams	35
4.8 Accessories.....	17	11.3 Approved accessories.....	40
5.0 Transport, packaging and storage	18	11.4 CE – Declaration.....	42
5.1 Safety information for transportation.....	18		
5.2 Transport inspection	19		
5.3 Return to the manufacturer.....	19		
5.4 Packaging.....	19		
5.5 Storage.....	19		

WARNING

Please read this manual before installing, operating or maintaining this lifting column. Failure to follow safety precautions and instructions could cause lifting column failure and result in serious injury, death or property damage. Keep this manual nearby for future reference.

1. General information

1.1 Information in this manual

This manual provides important information on how to work with the lifting column (also called the device) safely and efficiently. The manual is part of the device, must always be kept near the device and should be available for the personnel to read at any time. All personnel working with the device must read and understand this manual before starting any work. Strict compliance with all specified safety notes and instructions is a basic requirement.

Moreover, the accident prevention guidelines and general safety regulations applicable at the place of use of the device must also be complied with.

For better representation of circumstances, the illustrations in this manual are not necessarily to scale and may vary from the actual design of the device.

All information and notes in this manual were compiled with due consideration given to applicable standards and regulations, the present status of technology and our years of knowledge and experience.

1.2 Explanation of symbols and signal words

Safety precautions are identified by symbols and signal words defined on the right side of this page. These signal words indicate the severity of the hazard.

Adhere to these safety precautions and take actions in order to avoid accidents that may result in personal injuries or damage to property.

DANGER

Indicates a dangerous situation, which will lead to death or serious personal injury, if the precautionary measures are ignored.

WARNING

Indicates a dangerous situation, which can lead to minor or moderate injury or property damage, if the precautionary measures are ignored.

CAUTION

Indicates a dangerous situation, which can lead to minor or moderate injury if the precautionary measures are ignored.

NOTICE

Indicates information considered important, but not hazard-related (e.g. messages relating to property damage).

NOTE

Emphasizes useful hints and recommendations as well as information for efficient and trouble-free operation.

1.3 Limitation of liability

All information and notes in this manual were compiled under due consideration of valid standards and regulations, the present status of technology and our years of experience.

The manufacturer will not be liable for injury or damage resulting from:

- disregarding this manual
- unintended use
- employment of untrained personnel
- unauthorized conversions
- unauthorized technical modifications
- manipulation or removal of the screws on the device

Validity

The instructions in this manual refer to the lifting columns CPMA and CPMB with the following identification:

- Manufacturer: Ewellix
- Product name: Lifting columns CPMA and CPMB
- Type designation: CPMA1, CPMA2, CPMB1, CPMB2
- Year of manufacture: from 2013
- CE Mark: according to technical documentation

When the device has been customised by Ewellix, the actual product delivered may be different from what is described in this manual. In this case, ask Ewellix for any additional instructions or safety precautions relevant to these lifting columns.

We reserve the right to make technical modifications to the lifting column to improve usability.

1.4 Copyright

This manual is protected by copyright law and to be used exclusively by Ewellix customers for internal purposes.

Passing this manual on to third parties, duplication of any kind – even in the form of excerpts – as well as the use and/or disclosure of the contents without the written consent of the manufacturer is not permitted, except for internal uses.

Violation of Ewellix's copyright may become the subject of a future claim for damages.

1.5 Spare parts

This lifting column is not designed for repair by the user. All warranty and service claims become void without notice if any screws on the lifting column have been manipulated.

Genuine spare parts are available, for example:

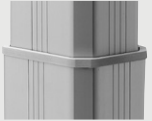
What	Where	Ordering number	Picture
Rim cover	On outer tube	ZAB-348390	

⚠ WARNING

Safety hazard caused by wrong spare parts

Wrong or faulty spare parts can adversely affect safety and cause damage, malfunctions or total failure.

Therefore, follow the precautions below:

- Use only genuine spare parts from the manufacturer.
- Spare parts in/on the device may only be replaced by the manufacturer.

If the device cannot be repaired on site by authorized personnel it must be dismantled from the application and sent to the manufacturer.

1.6 Warranty terms

The applicable and effective warranty terms are those contained in the manufacturer's terms and conditions of sale contained in the Ewellix sales contract that governs this sale.

1.7 Customer service

Ewellix Customer Service is always available to provide technical information and answer questions.

2. Safety

2.1 Use

Purpose of the CPMA and CPMB

The lifting columns CPMA and CPMB have been designed and built to be operated in accordance with their intended use. If you use the CPMA and/or CPMB for any use other than that cited, the manufacturer cannot be held responsible for any resulting damage or injury.

2.1.1 Intended use

The intended uses of the lifting columns CPMA and CPMB are:

- Dynamic, push load with movement in the vertical direction.
- For indoor use only.
- CPMA is designed for electrical height adjustment of ophthalmic table equipment and chairs.
- CPMB is designed for electrical height adjustment of baby incubators and baby warmers.

Product lifetime

The lifting columns CPMA and CPMB are designed for a service life of 10 years or 5 000 double strokes at a stroke length of 300 mm (with authorized usage) , whichever comes first.

2.1.2 Unintended and excluded use

Lifting columns CPMA and CPMB are suitable for indoor use only and must not be exposed to weathering, strong radiation fields, and corrosive or explosive atmospheric media (see **3.1 Ambient conditions**, page 13).

2.1.3 Essential performance

Lifting columns CPMA and CPMB are designed for electrical height adjustment.

2.2 Responsibility of the owner and processor

The device is designed for commercial applications by its owner or processor. The processor is the contracting partner of the reseller or the manufacturer. The processor installs the device in a complete system (application).

The owner or processor of the system is therefore subject to the requirements of the Occupational Health and Safety Act. In addition to the safety instructions in this manual, the owner or processor must do the following concerning safety and accident prevention guidelines and environmental protection regulations applicable to the site of the system's installation:

- Inform themselves of applicable industrial safety regulations. They must also determine additional hazards that arise due to the specific working conditions prevailing at the site where the device is installed, using risk assessment. The risk assessment must be implemented in the form of work instructions for device operation.
- Confirm that the work instructions created for the system, including the device, satisfy current legal requirements, and if not, alter the instructions accordingly.
- Clearly regulate and specify the responsibilities for installation, operation, maintenance, and cleaning.
- Ensure that all employees who deal with the device have read and understood this manual.
- Provide personnel with the required protective equipment.
- Provide training for personnel at regular intervals and inform personnel of the hazards.
- In addition the owner or the processor must ensure that the device is in adequate working condition. They must do the following: ensure that the maintenance intervals described in these instructions are complied with. Have all safety devices inspected regularly for function and completeness.

2.3 Personnel requirements

⚠ WARNING

Improper installation, operation and maintenance can result in serious injury, death or property damage.

Use only qualified, instructed, or trained personnel (as described below) who have read, understood and followed these instructions.

Qualifications

The following qualifications are specified for different areas of activity listed in this manual.

- **An instructed person (operator)**
Instructed by the customer in an orientation session on the assigned tasks and possible dangers arising from improper behaviour.
- **Qualified personnel**
Based on their professional training, know-how and experience as well as knowledge of the applicable standards and regulations, is able to independently perform assigned work activities and to detect and avoid possible dangers on their own.
- **Professional electrician**
Based on their professional training, know-how and experience, as well as knowledge of the applicable standards and regulations, is able to independently perform work on electrical systems and to detect and avoid possible dangers.
In addition, the professional electrician has been trained for the special location where they work and know the relevant standards and regulations.
Only persons who can be expected to perform their tasks reliably, are permitted to work with this device. Persons whose reaction capabilities are impaired, through the use of drugs, alcohol or medication, for example, are not permitted.

2.4 Specific dangers

The manufacturer has constructively, and with protective measures, minimized the effects of existing residual hazards. Pay attention to the residual hazards and potential countermeasures described in the following chapters.

⚠ WARNING

Crush hazard

Do not let any object or person come into contact with the inner tube and/or base plate of the inner tube while the motor is running. Hold the lifting columns CPMA and CPMB only by the external tube.

⚠ WARNING

Crush hazard

Risk of damage to the lifting columns CPMA and CPMB caused by static and dynamic overloading of the lifting column: Do not use the lifting column beyond the permissible operating data.

- Note the maximum permissible operating data in the Appendix (↳ **Equipment and operating data, page 34**)
- Note the product label of the lifting column.

⚠ WARNING

Pinch hazard

When the lifting column runs into fixed objects, the driving force can cause personal injury. If the lifting column is left unattended, check that the full stroke length is free of obstacles, and that there is nobody in the stroke area. Alternatively, provide a means of disconnecting all conductors from the mains power supply.

⚠ WARNING

Tip hazard

Use the lifting columns CPMA and CPMB always between the elements of the application, and with four screws to the upper and four screws to the lower base plate. The screws must be screwed to a depth of between 6 mm and 11 mm, with proper tightening torque.

⚠ WARNING

Excessive side-acting forces can destroy the column and pose a risk of serious injury. During the stroke, do not manipulate any of the elements connected to the lifting columns CPMA and CPMB.

- The maximum permissible values can be found in the appendix (see **Equipment and operating data, page 34**)

⚠ CAUTION

The lifting columns CPMA and CPMB are intended for use by healthcare professionals only. These lifting columns may cause radio interference or disrupt the operation of nearby equipment. It may be necessary to take mitigation measures, such as shielding the location.

⚠ CAUTION

The use of accessories and cables other than those for which the lifting columns CPMA and CPMB were designed, can significantly degrade electromagnetic EMISSIONS and IMMUNITY performance.

⚠ WARNING

The lifting columns CPMA and CPMB should not generally be used adjacent to or stacked with other equipment. If, however, adjacent or stacked use is necessary, the lifting columns should be kept under close observation to verify normal operation in this configuration.

⚠ WARNING

Electric shock hazard

Accessory socket box outlet. With provision of multiple sockets, all sockets are powered. Consequently sockets without plugs connected remain powered, and thus there is risk of electric shock from contacts not covered by plugs.

⚠ WARNING

Injury due to cracks and related openings in the housing of the lifting column and/or its accessories. If the housing is damaged due to shock, breakage or heavy wear, cease using the device and follow the dismantling instructions (see **10.0 Dismantling, page 33**).

⚠ WARNING

Electric shock hazard

Ensure that cables cannot become pinched or damaged. Check that the mains voltage corresponds to nominal value on the product label. Ensure that the cabling is correctly installed in the cable channel.

⚠ CAUTION

Electric shock hazard

Beware of damage to the CPMA and CPMB caused by splashing or hose-directed water. The lifting columns CPMA and CPMB are, in accordance with IP20, not protected against splashing or hose-directed water. Exposure to this risk must be prevented at all times.

- If required, protect your lifting column with appropriate protective measures.

⚠ CAUTION

Falling application can cause injury or damage. The base plate, which is made of plastic, can break when subjected to overload causing the application to fall. Do not operate the lifting column CPMA and CPMB without adequate support for the fastening plate or without an adapter plate! Mounting plates are available as accessories (see **11.3 Approved accessories, page 40**).

2.5 Safety equipment

⚠ WARNING

Electric shock hazard

The lifting columns CPMA and CPMB do not have an on / off switch and if required to be switched off, for example in an emergency, the lifting columns must be disconnected from the power supply. Only this measure will de-energize the lifting columns CPMA and CPMB.

Applications where the lifting columns CPMA and CPMB are built in, must provide an emergency stop switch or isolation from the mains supply on all conductors.

2.6 Safeguard against restart

⚠ WARNING

Life-threatening situation through unauthorized restart

For work in hazard zones, there is a risk that the power supply could be turned on without prior authorization. This presents a potentially life-threatening situation for people in hazard zone.

- Read information contained in this manual, concerning safeguard against any unintentional restart of the power supply.
- Always follow the procedure described below.

2.7 Modifications of device

⚠ WARNING

To avoid hazardous situations and to ensure optimal performance, do not make any changes or modifications to the device unless they have been specifically authorized by Ewellix.

2.7.1 Warning labels

⚠ WARNING

For lifting columns CPMA and CPMB no warning labels are applied.

2.7.2 Information label

Figure 1

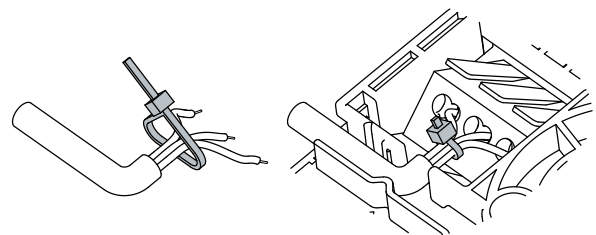

Fit a cable tie in order to secure the wires. The cable tie should be secured as close to the terminal as possible.

Figure 2

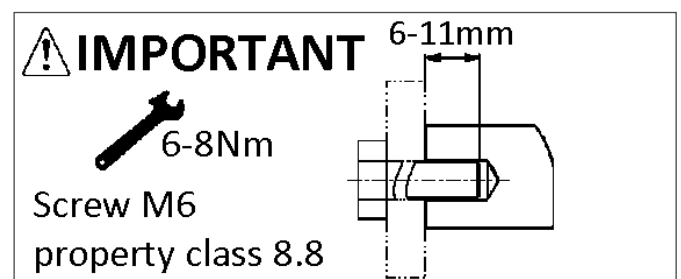

The column must be attached on plane and rigid surface by 4 screws M6 with depth of 6 to 11 mm in the column. The total length of the screw must be adjusted to the height of the fixture.

2.8 Manufacturer's declaration of EMC compliance

IEC/EN 60601-1-2:2007

Medical Electrical Equipment, Part 1-2:

General requirements for safety

Additional standard: Electromagnetic

Compatibility-requirements and tests

Guidance and manufacturer's declaration – electromagnetic emissions (table 1 according IEC 60601-1-2)

The lifting columns CPMA and CPMB are intended for use in the electromagnetic environment specified below.

The customer or user of the lifting columns should ensure that they are used in such an environment.

Emissions test	Compliance	Electromagnetic environment – guidance
RF emissions CISPR 11	Group 1	The lifting columns CPMA and CPMB use only RF energy for their internal function. Therefore, their RF emissions are very low and not likely to cause any interference with nearby electronic equipment.
RF emission CISPR 11	Class B	CPMA1-2xxxxxx-xxx CPMB1-2xxxxxx-xxx CPMA1-1xxxxxx-xxx CPMB1-1xxxxxx-xxx CPMA1-xxxxxx-xxx with ZDV-348220-002 and ZDV-348221-002 CPMB1-xxxxxx-xxx with ZDV-348220-002 and ZDV-348221-002
RF emission CISPR 11	Class A	The combination of the lifting column CPMA1-xxxxxx-xxx or CPMB1-xxxxxx-xxx either with ZDV-348220-002 or with ZDV-348221-002 do not exceed the RF emission class of the combination of the same lifting column with ZDV-348220-002 and ZDV-348221-002.
Harmonic emission IEC 61000-3-2	Class A	The lifting columns CPMA and CPMB are suitable for use in all non-domestic establishments, and in domestic establishments and those directly connected to the public low-voltage power supply network that supplies buildings used for domestic purposes.
Voltage fluctuations/ flicker emissions IEC 61000-3-3	Complies	

Guidance and manufacturer's declaration – electromagnetic immunity (table 2 according IEC 60601-1-2)

The lifting columns CPMA and CPMB are intended for use in the electromagnetic environment specified below. The customer or user of the lifting columns should ensure that they are used in such an environment.

IMMUNITY test	IEC 60601 test level	Compliance level	Electromagnetic environment – guidance
Electrostatic discharge (ESD) IEC 61000-4-2	± 6 kV contact ± 8 kV air	± 6 kV contact ± 8 kV air	Floors should be wood, concrete or ceramic tile. If floors are covered with synthetic material, the relative humidity should be at least 30%
Electrical fast transient/burst IEC 61000-4-4	± 2 kV for power supply lines ± 1 kV for input/output lines	± 2 kV for power supply lines ± 1 kV for input/output lines	Mains power quality should be that of a typical commercial or hospital environment.
Surge IEC 61000-4-5	± 1 kV line(s) to line(s) ± 2 kV line(s) to earth	± 1 kV differential mode ± 2 kV common mode	Mains power quality should be that of a typical commercial or hospital environment.
Voltage dips, short interruptions and voltage variations on power supply input lines IEC 61000-4-11	<5% U1 (>95% dip in U1) for 0.5 cycle 40% U1 (60% dip in U1) for 5 cycles 70% U1 (30% dip in U1) for 25 cycles <5% U1 (>95% dip in U1) for 5 s	<5% U1 (>95% dip in U1) for 0,5 cycle 40% U1 (60% dip in U1) for 5 cycles 70% U1 (30% dip in U1) for 25 cycles <5% U1 (>95% dip in U1) for 5 s	Mains power quality should be that of a typical commercial or hospital environment. If the user of lifting columns CPMA and CPMB requires continued operation during mains power interruptions, it is recommended that the lifting columns CPMA and CPMB are powered from an uninterruptible power supply or a battery.
Power frequency (50/60 Hz) magnetic field IEC 61000-4-8	3 A/m	3 A/m	If distortion occurs, it may be necessary to position the lifting columns CPMA and CPMB further from sources of power frequency magnetic fields, or to install magnetic shielding. The power frequency magnetic field should be measured in the intended installation location to ensure that it is sufficiently low.

NOTE: U1 is the a.c. mains voltage prior to application of the test level.

Guidance and manufacturer's declaration – electromagnetic immunity (table 4 according IEC 60601-1-2)

The lifting column CPMT is intended for use in the electromagnetic environment specified below.
The customer or the user of lifting column should ensure that it is used in such an environment.

Immunity test	IEC 60601 test level	Compliance level	Electromagnetic environment – guidance
Conducted RF IEC 61000-4-6	3 Vrms 150 kHz to 80 MHz	3 Vrms	Portable and mobile RF communications equipment should be used no closer to any part of the lifting column CPMT, including cables, than the recommended separation distance calculated from the equation applicable to the frequency of the transmitter.
Radiated RF IEC 61000-4-3	3 V/m 80 MHz to 2,5 GHz	3 V/m	

Recommended separation distance

$$d = 1,2 \sqrt{P}$$

$$d = 1,2 \sqrt{P} \text{ 80 MHz to 800 MHz}$$

$$d = 2,3 \sqrt{P} \text{ 800 MHz to 2,5 GHz}$$

where P is the maximum output power rating of the transmitter in watts (W) according to the transmitter manufacturer and d is the recommended separation distance in meters (m).

Field strengths from fixed RF transmitters, as determined by an electromagnetic site survey¹⁾, should be less than the compliance level in each frequency range²⁾.

Interference may occur in the vicinity of equipment marked with the following symbol:



NOTE 1: At 80 MHz and 800 MHz, the higher frequency range applies.

NOTE 2: These guidelines may not apply in all situations. Electromagnetic propagation is affected by absorption and reflection from structures, objects and people.

¹⁾ Field strengths from fixed transmitters, such as base stations for radio (cellular/cordless) telephones and land mobile radios, amateur radio, AM and FM radio broadcast and TV broadcast cannot be predicted theoretically with accuracy. To assess the electromagnetic environment due to fixed RF transmitters, an electromagnetic site survey should be considered. If the measured field strength in the location in which the lifting columns CPMA and CPMB are used exceeds the applicable RF compliance level above, the lifting columns CPMA and CPMB should be observed to verify normal operation. If abnormal performance is observed, additional measures may be necessary, such as re-orienting or relocating the lifting columns CPMA and CPMB.

²⁾ Over the frequency range 150 kHz to 80 MHz, field strengths should be less than 3 V/m.

Component list

Description			Part number	Cable length
Mains cable straight	Schuko	Germany, France, ...	ZKA-140449-2500	2,5m
Mains cable straight	Typ-L	Italy	ZKA-140450-2500	2,5m
Mains cable straight	British standard	UK	ZKA-140451-2500	2,5m
Mains cable straight	NEMA	USA, Japan, ...	ZKA-140452-2500	2,5m
Mains cable straight	SEV	CH	ZKA-140458-2500	2,5m
Mains cable straight	AS 3112	PRC, Australia, ...	ZKA-140460-2500	2,5m
Detachable mains cord straight	Schuko	Germany, France, ...	ZKA-140453-2500	2,5m
Detachable mains cord straight	Typ-L	Italy	ZKA-140454-2500	2,5m
Detachable mains cord straight	British standard	UK	ZKA-140455-2500	2,5m
Detachable mains cord straight	NEMA	USA, Japan, ...	ZKA-140456-2500	2,5m
Detachable mains cord straight	SEV	CH	ZKA-140459-2500	2,5m
Detachable mains cord straight	AS 3112	PRC, Australia, ...	ZKA-140461-2500	2,5m
Desk switch with LED			STK01-SW3000-X100	0,5m
Desk switch with LED			STK01-UW3000-X100	1,0m
Hand switch with LED			EHA41-13N10N-000	Cable coiled 1,3m
Foot switch			STL01-GW1000-X190	Cable coiled 1,3m
Socket box inlet			ZDV-348220-002	Not applicable
Socket box outlet			ZDV-348221-002	Not applicable

Recommended separation distances between portable and mobile RF communications equipment and the lifting columns CPMA and CPMB (table 6 – IEC 60601-1-2)

The lifting columns CPMA and CPMB are intended for use in the electromagnetic environment in which radiated RF disturbances are controlled. The customer or user of the lifting columns CPMA and CPMB can help prevent electromagnetic interference by maintaining a minimum distance between portable and mobile RF communications equipment (transmitters) and the lifting columns CPMA and CPMB as recommended below, according to the maximum output power of the communications equipment.

Rated maximum output power of transmitter [W]	Separation distance according to frequency of transmitter [m]		
	150 kHz to 80 MHz $d = 1,2 \sqrt{P}$	80 MHz to 800 MHz $d = 1,2 \sqrt{P}$	800 MHz to 2,5 GHz $d = 2,3 \sqrt{P}$
0,01	0,1	0,1	0,2
0,1	0,4	0,4	0,7
1	1,2	1,2	2,3
10	3,8	3,8	7,3
100	12,0	12,0	23,0

For transmitters rated at a maximum output power not listed above, the recommended separation distance d in meters (m) can be estimated using the equation applicable to the frequency of the transmitter, where P is the maximum output power rating of the transmitter in watts (W) according to the transmitter manufacturer.

NOTE 1: At 80 MHz and 800 MHz, the separation distance for the higher frequency range applies.

NOTE 2: These guidelines may not apply in all situations. Electromagnetic propagation is affected by absorption and reflection from structures, objects and people.

CAUTION

The use of accessories and cables other than those for which the lifting columns CPMA and CPMB were designed, can significantly degrade electromagnetic EMISSIONS and IMMUNITY performance.

NOTE

The use of the lifting columns CPMA and CPMB in an environment of immunity to voltage dips can halt the movement of the lifting column. As a start will not occur when there is no movement, this is a safe situation. The behaviour has no safety implications.

3. Technical data

NOTE

The technical data (dimension, weight, connection details etc.) can be found in the appendix (see **11.1 Technical data, page 34**).

3.1 Ambient conditions

- Temperature range: +10 to +40 °C
- Atmospheric humidity: 0% to 85%
- Non-condensing
- Atmospheric pressure: 700 to 1 060 hPa

The lifting columns CPMA and CPMB are suitable for indoor use only and must not be exposed to weathering, strong radiation fields or corrosive or explosive atmospheric media.

3.2 Product label

Figure 3

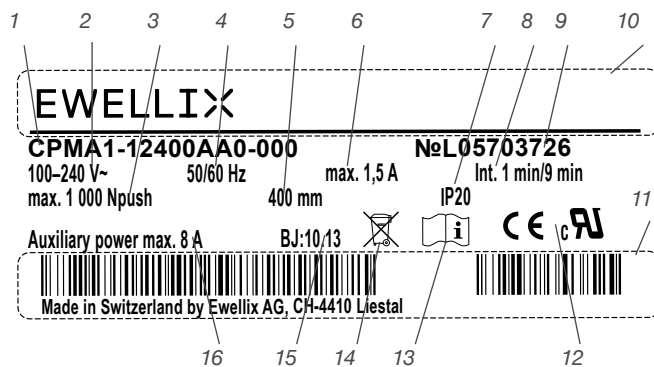

The product label provides the following information:

1. Type designation
2. Voltage
3. Force
4. Frequency
5. Stroke
6. Maximum current consumption
7. Ingress protection class
8. Operating time
9. Serial number
10. Manufacturer-specific company name
11. Manufacturer-specific barcode and address
12. Declaration and approvals
13. Recommendation to read operating manual

- 14. Disposal
- 15. Date of manufacture (month/year)
- 16. Current through

4. Structure and function

This chapter is intended for all users of lifting columns CPMA and CPMB, and describes their construction and function.

4.1 Overview

The following figure provides an overview of the lifting column.

Figure 4

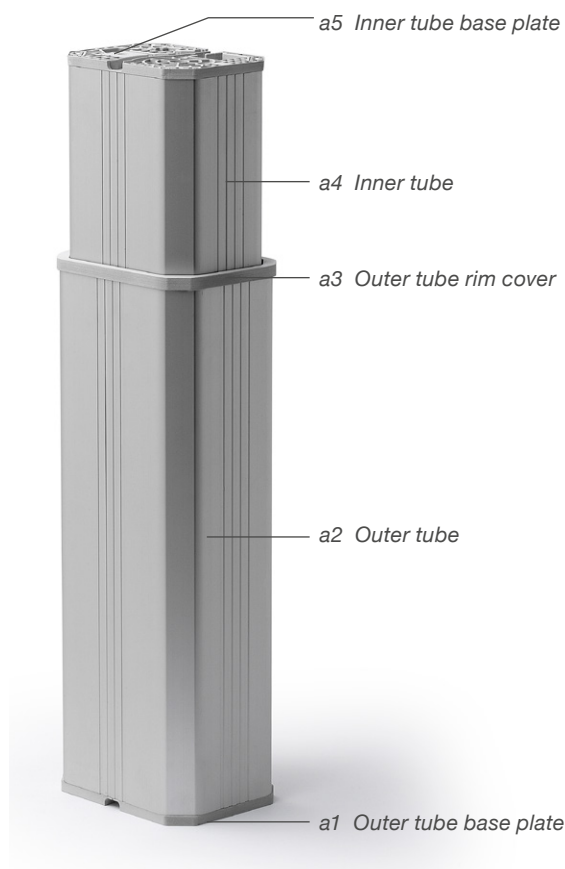

The outer tube can be placed at the bottom or the top, depending on the installation of the application.

Base plate view of lifting columns CPMA and CPMB

Lifting columns CPMA and CPMB without optional LAN cable through

Figure 5

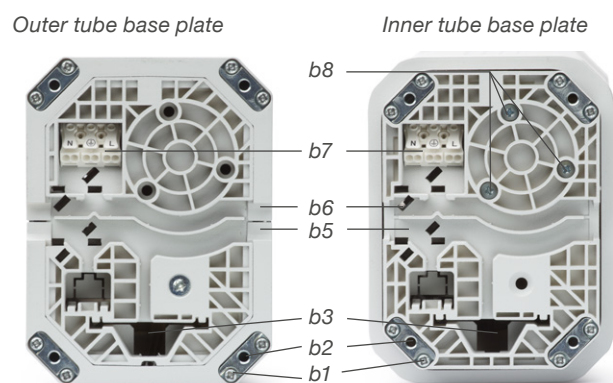

Lifting columns CPMA and CPMB with optional LAN cable through

Figure 6

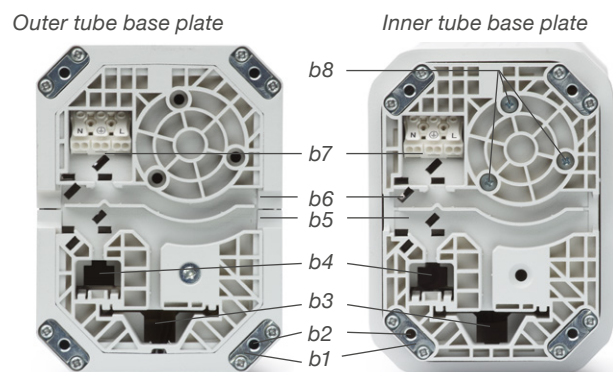

- b1.** Connection nut
- b2.** Thread M6 in connection nut for fastening screw
- b3.** Terminal for operating device and terminal for operating device through on the opposite side of the motor mounted base plate (only if corresponding option selected)
- b4.** Terminal for LAN cable through (only if corresponding option selected of the lifting column CPMA)
- b5.** LAN cable and operating device cable channel
- b6.** Mains cable channel
- b7.** Terminal for mains feed through
- b8.** Screws of motor mounted base plate (if option selected of motor orientation with motor in inner tube, otherwise the screws are in the outer tube base plate)

Figure 7

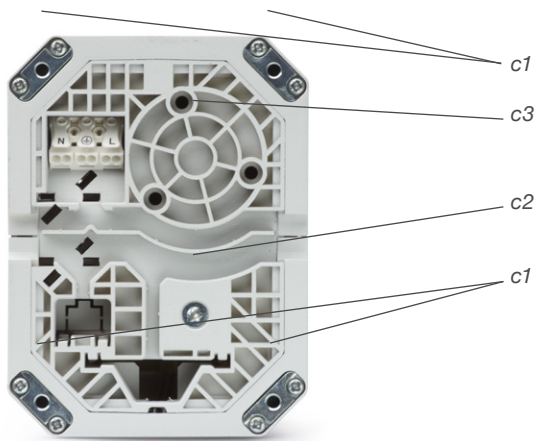

c1, c2, c3 Areas for force distribution

4.2 Brief description

A description of their function enables better understanding of what lifting columns CPMA and CPMB and their individual parts do.

Functional principles

The functional principle of the lifting columns CPMA and CPMB is based on a pushing force for the movement of centric and eccentric loads. The lifting columns CPMA and CPMB have an integrated control unit and power supply which is used as an individual lifting column.

A DC motor drives a lead screw via a bevel gear. A spindle nut, which is attached to the push tube, moves up and down on the lead screw. The telescopic tubes extend and retract depending on the direction of the motor. The built-in brake decelerates the movement or holds the position at a standstill.

The lifting columns CPMA and CPMB for 100–240 V AC are equipped with AC mains connection, and the mains voltage is internally transformed to 24 V DC. The lifting columns CPMA and CPMB for 24 V DC are equipped with DC connection and the voltage is internally transferred to the control unit.

Control unit

The DC motor is driven via an integrated control unit. The control unit controls the running direction of the lifting column and is equipped with an encoder for position detection. During the acceleration or deceleration phase, the lifting columns CPMA and CPMB use a soft start and soft stop function, which allows smooth running without jerking motion. This function is automatically activated when buttons on the operating device are pressed or released, or when the end position is reached.

End position

The stroke is limited by the integrated control unit. If the lifting columns CPMA and CPMB move beyond the end position (in the case of a malfunction), after 3 mm a mechanical block stops the movement. The control unit interrupts the movement and the CPMA and CPMB can no longer be moved in the blocking direction.

Outer tube base plate (a1)

The outer tube base plate has four connection nuts (**b1**) for the fastening screws M6. Its purpose is to fasten the column to one side of the application. The outer tube base plate must be attached permanently with fastening screws M6 to a flat metal surface in the application, which has to support the areas of force distribution (**c1, c2, c3**).

Outer tube (a2)

The outer tube is the tube with larger outside dimensions. The outer tube can be located in upper or lower position of lifting columns CPMA and CPMB.

Outer tube rim cover (a3)

The purpose of the rim cover for the outer and inner tube is to protect the tubes' guiding system from dust and to prevent the ingress of foreign matter according to IP20. It must not be removed under any circumstances.

Inner tube (a5)

The inner tube is the tube with smaller outside dimensions. The inner tube can be located in upper or lower position of lifting columns CPMA and CPMB.

Inner tube base plate (a7)

The inner tube base plate has four connection nuts (**b1**) for the fastening screws M6. Its purpose is to fasten the column to the other side of the application. The inner tube base plate must be attached permanently with fastening screws M6 to a flat metal surface in the application, which has to support the areas of force distribution (**c1, c2, c3**).

4.3 Special features

Guide tube unit (a2, a4)

The guide tube unit is made up of the outer tube (**a2**) and the inner tube (**a4**), and its purpose is to carry centric and eccentric loads.

Drive unit

The permanent magnet motor is a 24 V DC motor and drives the lead screw via the bevel gear. The speed of the movement depends on the load and the direction of the movement. The motor location can be selected on the inner tube base plate or the outer tube base plate.

Bevel gear

The bevel gear drives the lead screw. It is driven via the permanent magnet motor.

Thermo-switch

The thermo-switch in the control unit controls thermal and electrical overload and switches off the permanent magnet motor in an emergency. The column cannot be operated again until the drive temperature has fallen below the switching threshold.

Switching off in the event of overcurrent

The control unit has an integrated switch-off facility in the event of overcurrent, which protects the column from overload.

Brake

The brake is attached to the lead screw, and its purpose is to decelerate the lead screw and hold the position.

4.4 Requirements for third party power supply (mandatory for lifting columns CPMA and CPMB 24 V DC in medical applications)

The operating voltage of lifting columns CPMA2 and CPMB2 is 24 V DC. The no-load voltage of 32 V DC must not be exceeded.

- After the system has been installed, ensure EMC compliance.
- The third party power supply must have an isolation between the primary and secondary circuits according to 2 MOPP and provide a non-grounded secondary circuit.
- The third party power supply must be able to draw currents up to 20 A for 200 ms after switching on (start-up current). For starting movement of the lifting columns CPMA or CPMB, it must be able to draw currents up to 6,5 A for 1,6 s for nominal load pushing. During movement according to the duty cycle of 1 minute ON and 9 minutes OFF, it must be able to draw current up to 5 A.

4.5 Connections

Connection nut (b1)

The lower base plate and upper base plate are equipped with connection nuts in each corner. The purpose of the base plates is to attach the column to the flat metal surface in the application with fastening screws. The connection nuts must not be removed under any circumstances.

Thread in connection nut (b2)

The purpose of the M6 thread in the connection nut is to fasten the column to the application with fastening screws. The fastening screws must have a screw-in depth of between 6 mm (min) and 11 mm (max) in addition to the interface width of the application.

Terminal for operating device (b3)

The terminal for the operating device provides connection for the operating device plug. Standard configuration is with the operating device socket on the side of the motor. If the optional configuration of an operating device on both sides is selected, then the terminal on the opposite base plate provides a connection for the second operating device.

Terminal for LAN cable through (b4)

The terminal for LAN cable through supplies connections on both base plates for the LAN plug. It is necessary to use a LAN cable with shielded plugs and for it to be shorter than 2 m on the bottom of the column to provide connection to the network. This optional LAN cable through can only be selected if the operating device through is not selected.

LAN and operating device cable channel (b5)

The cable channel provides space to place the cable for operating device or LAN cable (CPMA only).

Mains cable channel (b6)

The cable channel provides space to place the mains cable. The mains cable must be equipped with an outside diameter of 8,2 mm \pm 0,5 mm.

Terminal for mains feed through (b7)

The terminal for the mains cable supplies external devices with power via the mains cable feed through.

Areas for force distribution (c1, c2, c3)

The outer tube base plate and the inner tube base plate must be attached to a flat metal surface in the application. The areas for force distribution have to be supported in the application, and this support must not be removed under any circumstances. The flat metal surfaces must be attached for force reasons and for EMC compliance according to IEC/EN 60601-1-2.

4.6 Operating elements

The Ewellix operating devices are available as accessories for lifting columns CPMA and CPMB. The desk switch is designed to be fixed on a table, and the foot switch is designed to be placed on the floor or fixed on a flat surface close to the floor. The hand switch is shaped, so that unintentional pushing is avoided. If you have any queries, please consult the corresponding chapter on accessories.

4.7 Options

Options can be recognized from the type designation on the product label.

Voltage

There are two voltage options for this lifting column: 100–240 V AC and 24 V DC. The lifting column CPMA and CPMB is always equipped with a mains cable through.

IMPORTANT: The mains supply must be connected from only one side at a time.

Load

The lifting columns CPMA and CPMB in voltage 100–240 V AC are designed for 1 000 N or 2 000 N. The lifting columns CPMA and CPMB in voltage 24 V DC are designed for 2 000 N.

Tube set

The tube set is defined as a two-section tube set.

Stroke length

The available stroke length for CPMA and CPMB 100–240 V AC is from 230 mm up to 400 mm in 10 mm steps. The available stroke length for CPMA and CPMB 24 V DC is from 200 mm up to 400 mm in 10 mm steps.

Motor orientation

The motor of lifting columns CPMA and CPMB can be placed in either the inner or outer tube.

Operating device orientation

The operating device socket is normally placed on the side of the motor. With the option operating device socket at both sides, one socket for operating device will be placed on the outer tube and the other on the inner tube base plate. This allows connection for using operating devices simultaneously at the bottom and the top.

LAN cable through

The optional LAN cable through is only available for CPMA. On each base plate is mounted a female RJ45 socket. The combination of optional LAN cable through with option operating device on both sides is not possible.

4.8 Accessories

Mains cable straight

2,5 m mains cables for 100–240 V AC with plugs for specific countries can be supplied as accessories. The mains cable is intended to be used in the base plate to facilitate the connection to the terminal mains feed through.

Detachable mains cord straight

Detachable mains cord with plug for specific countries and IEC-60320 C13 plug can be supplied as accessories. It is intended to be used together with the socket box inlet.

Desk switch with LED cable 0,5 m or 1,0 m

The desk switch is defined as an operating element to be connected on lifting columns CPMA and CPMB and mounted below the tabletop.

Hand switch with LED cable coiled 1,3 m

The lifting columns CPMA and CPMB can be controlled with a hand switch.

Foot switch without LED cable coiled 1,3 m

The lifting columns CPMA and CPMB can be controlled with a foot switch.

Mounting plate

The purpose of the mounting plates is to ensure that the fastened application is seated fully and solidly. The mounting plate will be fixed to the top or bottom base plate of the lifting column with four fastening screws M6.

Socket box inlet: IEC, RJ45 LAN, RJ45 operating device

The socket box inlet facilitates connection for detachable mains cord with plug IEC-60320 C13 on one side, RJ45 LAN and RJ45 connection for operating device on the other side. A metal plate is integrated and placed between the base plate and the application, fastened with four M6 screws.

Socket box outlet: 3xIEC, RJ45 LAN, RJ45 operating device

The socket box outlet facilitates three connections for mains cord with plug IEC-60320 C14, RJ45 LAN and RJ45 connection for operating device. In the electric circuit are two fuses integrated. A metal plate is integrated, offering the same function as the mounting plate.

Further details on accessories can be found in the appendix (see **11.3 Approved accessories, page 40**).

IMPORTANT: Ewellix will not accept liability for any damage caused if the lifting columns CPMA and CPMB are not used with an approved accessory as described in 11.2.

CAUTION

The use of accessories and cables other than those for which the lifting columns CPMA and CPMB were designed, can significantly degrade electromagnetic EMISSIONS and IMMUNITY performance.

5. Transport, packaging and storage

5.1 Safety information for transportation

⚠ CAUTION

Damage due to improper transport

Significant damage to the device may occur as a result of improper transport.

Therefore:

- Proceed carefully during delivery and unloading of the packaged items, as well as during transport to final destination. Comply with the symbols and information shown on the packaging.
- Do not remove the lifting column from its packaging until just before installation.
- Note storage requirements for return transport of the device to the manufacturer (see **5.5 Storage, page 20**).

5.2 Transport inspection

The lifting column is delivered as one packaged unit in a box or on pallets.

Check the delivery immediately upon receipt, for completeness and any signs of damage incurred during transport.

Check completeness of delivery for:

- A complete lifting column unit, with all packaged parts present.
- Any signs of damage to the plastic casing, such as cracks. If evident, protection in accordance with rated IP class is no longer guaranteed and the lifting column must be returned to the manufacturer.

If exterior transport damage is evident:

- Do not accept delivery or do so only under agreed conditions.
- Record scope of damage on the transport documents or bill of delivery of the shipping company.
- Initiate complaint.

NOTE

Report any damage as soon as possible, as damage claims can only be submitted within the transporter's applicable complaint period.

5.3 Return to the manufacturer

If device is damaged, arrange for return transport as follows:

Dismantle the device if necessary (see **10.0 Dismantling, page 33**).

Pack device in its original packaging. Follow storage conditions (see **5.5 Storage, page 20**).

1. Send to manufacturer. Contact Ewellix service to obtain a shipment address.

5.4 Packaging

Requirements:

All parts to be packaged appropriately for anticipated transport conditions, using only environmentally-friendly materials.

The packaging is designed to protect the individual components from damage caused by transport, corrosion and other risk factors until they are ready for installation. Only remove packaging shortly before installation. The packaging should not be destroyed, but kept for possible return shipment to the manufacturer (see **5.3 Return to the manufacturer, page 19**).

If the packaging is to be disposed of following satisfactory delivery, please note and adhere to the following:

NOTE

Packaging material consists of valuable raw materials, much of which can effectively be recycled and reused.

Therefore:

- Dispose of packaging material in an environmentally correct way.
- Comply with locally applicable disposal regulations.

5.5 Storage

For storage, pack the lifting columns CPMA and CPMB in their original packaging. Observe the following values when selecting a storage location:

- Do not store outside
- Dry and dust-free storage.
- Keep away from any aggressive media.
- Protect from UV radiation.
- Avoid mechanical vibrations.
- Storage temperature: -20 °C to $+60\text{ °C}$
- Atmospheric humidity: 0% to 90% , non-condensing
- Pressure: 700 to 1060 h Pa
- For storage longer than three months, check the general condition of all parts of the packaging on a regular basis.

NOTE

There may be notices on the packaging concerning additional storage requirements not listed here. If so, follow these accordingly.

6. Installation and first operation

This chapter is intended for technicians and those involved with further processing. It provides all the information needed to assemble, connect and start up lifting columns CPMA and CPMB.

Authorized personnel

- The installation and first start of operation may only be conducted by qualified personnel.
- All work on the electrical system may only be performed by professional electricians.

⚠ WARNING

Electric shock and moving parts hazards

Serious injury or death can be caused by touching live electrical components and by unexpected movement of the lifting column.

Be sure the system's power supply is off and the lifting column is locked out before installing.

⚠ WARNING

Danger if restarted

When correcting faults there is risk of the energy supply being switched on without authorization. This poses a life threatening hazard for persons in the danger zone.

Therefore:

- Prior to starting work, switch off the system and be sure it is locked out.

⚠ WARNING

Installation adjacent to other equipment

The device should not be installed adjacent to or stacked with other equipment. If adjacent or stacked use is necessary, the device should be trialed under observation, to verify normal operating in the configuration in which it will be used.

⚠ WARNING

Special precautions regarding EMC

The device requires special precautions regarding EMC and must be installed and put into service according to the EMC information provided in this operating manual (see **7.1 Safety, page 27**).

⚠ WARNING

Risk of injury and device damage due to incorrect installation of the optional devices

Therefore:

- Optional devices, in particular components that are part of a retrofit, may only be installed in accordance with their respective instructions (circuit diagram).
- Electromagnetic compatibility must be tested for the routing, and appropriate corrective measures carried out if necessary.

6.1 Installation location

- Adhere to the technical data for operating conditions.
- Install in a location where the lifting column is not exposed to strong UV radiation or corrosive or explosive air media.

6.2 Inspections prior to initial operation

To be performed by a professional electrician. Prior to first operation, a professional electrician must perform and document the following tests and reading:

- Visual condition check
- Function check of operating features and safety features
- Reading of leakage current
- Reading of insulation resistance

Installation check

⚠ WARNING

Crush hazard

Risk of damage to the lifting columns CPMA and CPMB caused by static and dynamic overload. Do not use the lifting column beyond the permissible operating data.

- Note the maximum permissible operating data in the Appendix (see **Equipment and operating data, page 34**).
- Note the product label of the lifting column.

Before initial start-up, check that the following points have been dealt with:

- All instructions followed, in above sections of this chapter.
- Grounding conductor resistance and substitute leakage currents checked according threshold of owner usage.
- No impermissibly high side-acting forces impacting on the guide tube unit.
- Fastening screws secured on inner tube base plates and outer tube base plates.
- Entire stroke area unobstructed so that lifting columns CPMA and CPMB cannot be driven onto a fixed object.
- All cables secured against pinching and trapping, and properly connected.
- Electrical supply secured.
- Operating device connected to the control unit.

Initial start-up

After the installation check has been completed, you can start up lifting columns CPMA and CPMB: With the LED on the operating light green, press the corresponding operating button of the operating device.

Prior to first operation, a professional electrician must perform and document the following tests and readings:

- Visual condition check
- Functional check of operating features and safety features
- Reading of leakage currents
- Reading of insulation resistance

NOTE

Additional information concerning inspections and readings (see **8.0 Maintenance, page 29**)

6.3 Installation

Installing the lifting columns CPMA and CPMB on other elements (chairs, tables, incubators and baby warmers, etc.) involves taking into account special requirements for different applications.

The lifting columns CPMA and CPMB must be attached to two flat metal surfaces of the application via the inner and outer tube base plates or optionally via mounting plates, or via the socket box inlet or outlet.

The following sections show how to set up and align the lifting columns CPMA and CPMB, including their interfaces and connections.

Set-up and adjustment

In setting up and aligning lifting columns CPMA and CPMB, the following points must be observed. For installation, you will require:

- a complete column unit
- an operating device
- a mains cable
- a LAN cable (only if selected)
- eight M6 fastening screws, property class 8.8, with screw-in depth between 6 and 11 mm in addition to the interface width of the application.

Figure 8

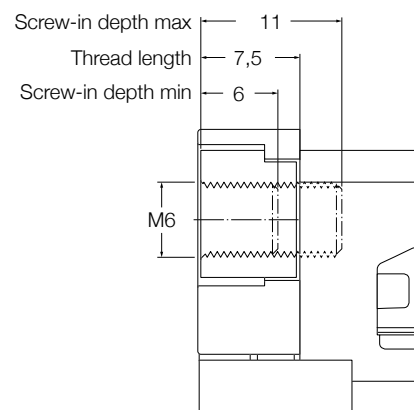

IMPORTANT: Socket box inlet and socket box outlet have integrated grounding cables (see **11.3 Approved accessories, page 41**). If additional electrical devices are attached, you must ensure that the connection meets the insulation requirements for protection class I.

Proceed as follows for installation:

⚠ WARNING

Hand crush hazard

Do not let any object or person come into contact with the inner tube and/or the base plate of inner tube while the motor is running. Hold the lifting columns CPMA and CPMB only by the external tube.

1. Connect the corresponding operating device to the lifting columns CPMA and CPMB on the terminal for the operating device (d6). Place the operating device cable in the LAN cable and operating device cable channel (d5). If LAN cable through is selected on the CPMA, then place the LAN cable, with short bending protection on the plug, in the LAN socket (d7).

Base plate view lifting columns CPMA and CPMB

Figure 9

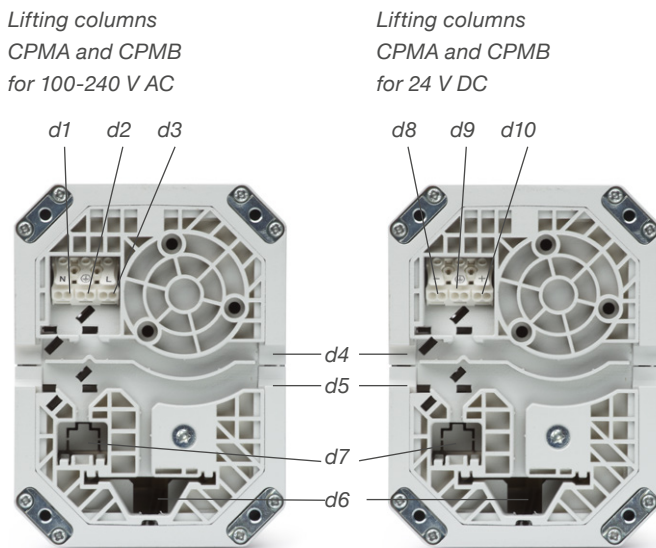

- d1. Terminal for mains cable neutral, N for 100-240 V AC
- d2. Terminal for mains cable earth, PE for 100-240 V AC
- d3. Terminal for mains cable phase, L for 100-240 V AC
- d4. Mains cable channel
- d5. LAN cable and operating device cable channel
- d6. Terminal for operating device and terminal for operating device through on the opposite side of the motor mounted base plate (only if corresponding option selected)
- d7. Terminal for LAN through (only if corresponding option selected of lifting column CPMA)
- d8. Terminal for mains cable, – for 24 V DC
- d9. Terminal for mains cable earth, PE for 24 V DC
- d10. Terminal for mains cable, + for 24 V DC

2. Connect the mains cable to the mains terminals.
For lifting columns CPMA and CPMB 100-240 V AC: First, connect mains cable PE with PE terminal, then connect mains cable N with N terminal and finally, connect mains cable L with terminal L.

For lifting columns CPMA and CPMB 24 V DC:

First connect mains cable PE with PE terminal, then connect mains cable – with – terminal and finally, connect mains cable + with terminal +.

Place the mains cable in the mains cable channel (d4) for strain relief. Choose the cable channel to the left or right side of the base plate according to the application.

Fit a cable tie in order to secure the wires. The cable tie should be secured as close to the terminal as possible.

Figure 10

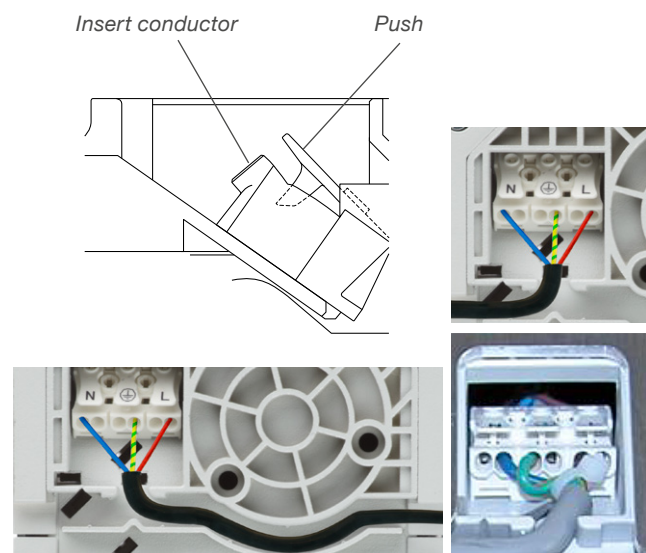

⚠ WARNING

Electric shock hazard

Ensure that cables cannot get pinched or damaged. Check that the mains voltage corresponds to the nominal value on the product label. Ensure that the strain relief clamp and cabling are placed correctly.

You can find the nominal values in the appendix (see **Equipment and operating data, page 34**).

IMPORTANT: The mains supply must only be provided from one side. The mains cable wires must be stripped from the insulation for a length of 5–10 mm to ensure a reliable connection, and the PE connection wire needs to be 10 mm longer than the others. When using your own mains cable, comply with cable specification of maximum 2,5 m length, outside diameter 8,2 mm +/-0,5 mm with stranded wire cross section at least 3x1 mm².

For mains power supply, lifting column CPMA and CPMB requires two fuses each of 250 V AC, rated current 8 A and with high breaking capacity integrated. Alternatively, the lifting column can be installed with the socket box inlet.

- Secure the elements that you want to connect to the lifting column, so that you can place the CPMA and CPMB between them.

CAUTION

Falling application can cause injury or damage. The base plate, which is made of plastic, can break when subjected to overload. Do not operate the lifting columns CPMA and CPMB without an adapter plate! Mounting plates are available as accessories (see **11.3 Approved accessories, page 17**).

- Connect the base plates with one flat metal surface each of the application using four fastening screws M6 on each side of the lifting columns CPMA and CPMB.

IMPORTANT: Screw in to a maximum of 11 mm. It is important that the screw is inserted at least 6 mm in addition to the interface width of the application. The screws must be at least property class 8.8 with tightening torque of 6 Nm.

Figure 11

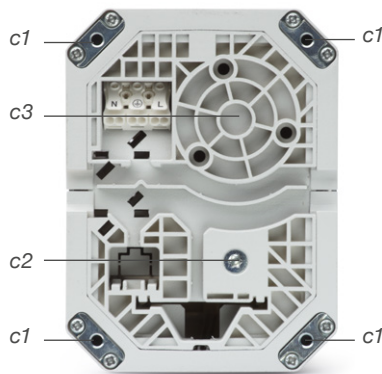

- c1. Areas for force distribution, connection nuts
- c2, c3. Areas for force distribution

Figure 12

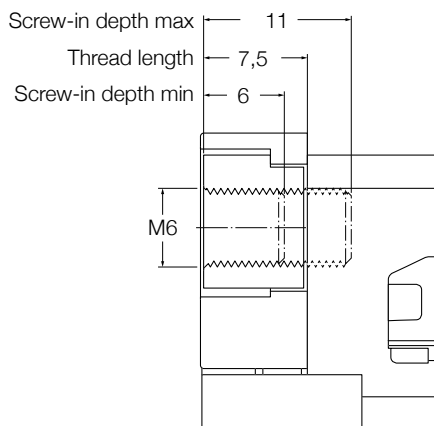

- Check that all screws are sufficiently secured so that they do not loosen on their own.

NOTE

Fastening screws are not supplied. The bore dimensions can be found in the section see **11.2 Plans and diagrams, page 35**. Please ensure that the screws cannot inadvertently become loose.

- Check that all interfaces and connections have been mounted and/or connected correctly.
- You can now operate the lifting column, using the corresponding operating device.

IMPORTANT: Ewellix will not accept liability for any damage caused by lifting columns CPMA and CPMB that are not used with a suitable operating device and corresponding flat metal surfaces on outer tube and inner tube base plates.

Make sure that:

- the lifting column is attached to the flat metal surfaces of the application on both sides.
- all attachment points are securely screwed to the application.
- the elements are fully aligned and seated at the top and bottom.
- the areas for force distribution are supported.
- the acting force does not impact the guide tubes with inadmissibly high values, as side-impacting forces that are too high can destroy the lifting columns CPMA and CPMB.
- the lifting column is not obstructed in any way in the entire lifting area.
- the cables are not pinched or caught, or subject to tension stress.
- the lifting column CPMA and CPMB has in the mains power supply two integrated fuses of 8 A each, or alternatively installed with a socket box inlet.

6.4 Connection to power supply

The lifting column CPMA and CPMB runs solely on electricity. Find the connection values in the appendix of this manual (see **Equipment and operating data, page 34**).

6.5 Requirements concerning installation of accessories

IMPORTANT: Please read carefully the procedure for installation. (see **6.3 Installation, page 22**).

Desk switch with LED cable 0,5 m or 1 m

The lifting columns CPMA and CPMB can be associated with a desk switch connected at the terminal for the operating device. After completion of the installation of the column in the application, the desk switch can be screwed into the application using two M4 screws. See the dimensional diagram in the appendix (see **11.3 Plans and diagrams, page 35**).

Hand switch with LED cable coiled 1,3 m

The lifting columns CPMA and CPMB can be associated with a hand switch connected at the terminal of the operating device. See the dimensional diagram in the appendix (see **11.2 Plans and diagrams, page 35**).

Foot switch without LED cable coiled 1,3 m

The lifting columns CPMA and CPMB can be associated with a foot switch connected at the terminal of the operating device. A second device with an LED must be added to the application in order to gain feedback on the current running situation: normal operation or special. See the dimensional diagram in the appendix (see **11.2 Plans and diagrams, page 35**).

Socket box inlet: IEC RJ45 LAN, RJ45, operating device

The socket box inlet has to be added to the lifting column 100-240 V AC (CPMA1 and CPMB1) to connect the mains power supply to the IEC-60320 C13 plug and one RJ45 for LAN and one RJ45 for the operating device. The IEC socket has a steel retainer clip and is protected with two fuses each of 8 A for safety (Rated voltage 250 V AC, rated current 8 A, high breaking capacity). The socket RJ45 for LAN is by with the standard network symbol (Ⓜ) and the socket RJ45 for the operating device by an up and down arrow symbol (Ⓜ). The metal plate of the socket box must be mounted between the base plate of the column and the elements of the application.

IMPORTANT: Be careful during installation of the socket box: the socket box can only be mounted in one direction (ensure alignment of the opening in the metal plate with the base plate).

Installation

1. Connect the longer wire with RJ45 plug into the terminal for the operating device. Connect the shorter wire with RJ45 plug into the terminal for LAN through device. If the lifting column is not equipped with LAN through or operating device socket, then cut the RJ45 plug. Place the cables in the channel.
2. Connect the mains cable to the mains terminal. First, connect mains cable PE (green-yellow) with PE terminal, then connect mains cable N (blue) with N terminal, and, finally, connect mains cable L1 (brown) with terminal L. Place the mains cable in the channel. Attach a cable tie in order to secure the wires. The cable tie should be secured as close to the terminal as possible.

Figure 13

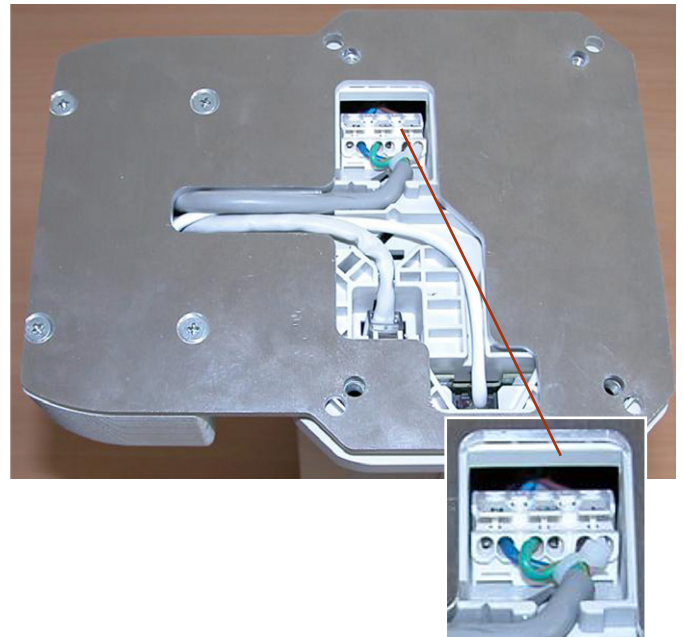

⚠ WARNING

Electric shock hazard

Ensure that cables cannot become pinched or damaged. Check that the mains voltage corresponds to nominal value on the product label. Ensure that the cabling is correctly installed in the cable channel.

3. Fasten the four countersunk screws M6×12 in the threads of the connection nuts.
4. Proceed by following steps 3-7 of see **6.3 Installation, page 22**. See the dimensional diagram in the appendix (see **11.2 Plans and diagrams, page 35**).

Socket box outlet: 3xIEC, RJ45 LAN, RJ45 operating device

The socket box outlet can be added to the lifting column 100-240V AC (CPMA1 and CPMB1) to connect up to three mains power supplies with IEC-60320 C14 plug and one RJ45 for LAN and one RJ45 for operating device. The socket RJ45 for LAN is identified by the standard network symbol (☎) and the socket for RJ45 for the operating device by the up and down arrow symbol (↕). The multiple outlet is protected with two fuses each of 8 A (Rated voltage 250 V AC, rated current 8 A, high breaking capacity) located in the fuse holder marked with the fuse symbol (⊖). Included in the socket box is a metal plate, which has the same function as the mounting plate.

IMPORTANT: Be careful during the installation of the socket box: the socket box can only be mounted in one direction (ensure alignment of the opening in the metal plate with the base plate).

Installation

1. Connect the longer wire with RJ45 plug into the terminal for operating device. Connect the shorter wire with RJ45 plug into the terminal for LAN through.
If the lifting column is not equipped with LAN through or operating device socket, then cut the RJ45 plug. Place the cables in the channel.
2. Connect the mains cable to the mains terminal. First, connect mains cable PE (green-yellow) with PE terminal, then connect mains cable N (blue) with N terminal and, finally, connect mains cable L1 (brown) with terminal L. Place the mains cable in the channel. Attach a cable tie in order to secure the wires. The cable tie should be secured as close to the terminal as possible.

Figure 14

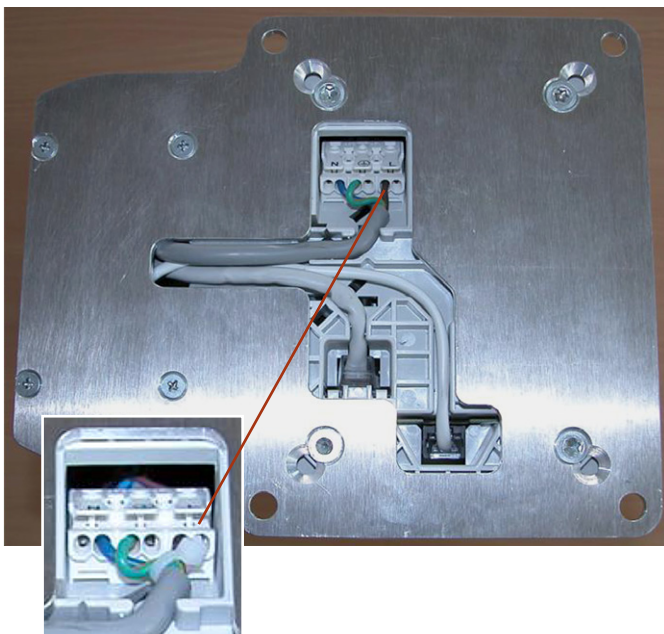

⚠ WARNING

Electric shock hazard

Ensure that cables cannot become pinched or damaged. Check that the mains voltage corresponds to nominal value on the product label. Ensure that the cabling is correctly installed in the cable channel.

3. Fasten the four countersunk screws M6x12 in the threads of the connection nuts.
4. Proceed by following steps 3-7 following of see 6.3 **Installation, page 22.**
See the dimensional diagram in the appendix (see 11.2 **Plans and diagrams, page 35).**

6.6 Initial start-up

Perform the installation check before starting up the lifting columns CPMA and CPMB for the first time.

Installation check

⚠ WARNING

Crush hazard

Risk of damage to the lifting columns CPMA and CPMB caused by static and dynamic overloading of the lifting column. Do not use the lifting column beyond the permissible operating data.

- Note the maximum permissible operating data in the appendix (see **Equipment and operating data, page 34**)
- Note the type plate on the lifting column

Before initial start-up, check that the following precautions have been taken care of:

- All instructions followed in above sections of this chapter.
- Grounding conductor resistance and substitute leakage currents checked.
- No impermissibly high side-acting forces impacting on the guide tube unit.
- Fastening screws secured on inner tube base plates and outer tube base plates.
- Entire stroke area unobstructed so that the lifting columns CPMA and CPMB cannot be driven onto a fixed object.
- All cables secured against pinching and trapping and properly connected.
- Electrical supply secured.
- Operating device connected to the control unit.

Initial start-up

After the installation check has been completed, you can start up the lifting columns CPMA and CPMB: When the operating light turns green on the LED, press the corresponding operating button of the operating device.

7. Operation

This chapter is intended for owners and operators. It provides all of the information required for safe and proper operation of lifting columns CPMA and CPMB under normal operating conditions.

7.1 Safety

⚠ WARNING

Crush hazard!

There is a risk of serious injury from crushing in the operating environment of the device.

Therefore:

- Ensure that no persons are in the stroke area of the device while it is in operation.
- Take note of maximum permissible performance specifications for the device (see **11.0 Appendix, page 34**).
- Never tamper with the elements connected to the device while the device is in operation.

⚠ WARNING

Excessive side-acting forces can destroy the column and pose a risk of serious injury. During the stroke, do not manipulate any of the elements connected to the lifting columns CPMA and CPMB.

- You can find the maximum permissible values in the appendix (see **Equipment and operating data, page 34**)

⚠ WARNING

Risk of injury due to cracks and related openings in the housing of the lifting column and/or its accessories. If the housing is damaged due to shock, breakage or heavy wear, cease using the device and follow the dismantling instructions (see **10.0 Dismantling, page 33**).

⚠ WARNING

Risk of injury due to cracks and related openings in the housing of the lifting column and/or its accessories. If the housing is damaged due to shock, breakage or heavy wear, cease using the device and follow the dismantling instructions (see **10.0 Dismantling, page 33**).

⚠ WARNING

Device damage due to static and dynamic overload of the device
Therefore:

- Do not exceed maximum permissible performance specifications for the device (see **11.0 Appendix, page 34**).
- Never exceed nominal load.

⚠ WARNING

Electric shock hazard

Ensure that cables cannot get pinched or damaged. Check that the mains voltage corresponds to nominal value on the product label. Ensure that the cabling is correctly installed in the cable channel.

NOTE

Lifting column may be damaged if liquids penetrate during extension and retraction. Keep liquids away.

7.2 Turn on

Preconditions for operation

The lifting columns CPMA and CPMB are driven via the integrated control unit and the corresponding operating device (see **4.8 Accessories, page 17**).

7.3 Turn off

The lifting columns CPMA and CPMB do not have an on / off switch. To de-energize, the lifting columns must be disconnected from the power supply.

7.4 Action before use

The lifting column must be connected to mains electricity and is operated by an operating device (see **4.8 Accessories, page 17**).

7.5 Action during operation

The lifting columns CPMA and CPMB have been designed for intermittent or short-term use (see **Equipment and operating data, page 34**). If a higher duty cycle is used, contact Ewellix (see **5.3 Return to manufacturer, page 19**).

7.5.1 Normal operation

Under normal operation, lifting columns CPMA and CPMB lift or lower elements connected to the lifting columns via the inner and outer tube base plate.

Use directional buttons UP and DOWN on the operating device to operate lifting columns CPMA and CPMB:

- Button UP: The lifting columns CPMA and CPMB extends.
- Button DOWN: The lifting columns CPMA and CPMB retracts.

On the operating device is a green LED indicating normal operation.

The lifting columns CPMA and CPMB move until the button is released or the end position is reached. The stopping of the movement is a “soft stop”. Therefore the traveling distance of the lifting column from releasing the button until stop is related to the speed and force direction.

The lifting columns will stop if buttons Up and DOWN are pressed at the same time.

NOTE

Excessive current consumption, unusual noises or an unwanted downward movement, indicate damage to lifting columns CPMA and CPMB. Cease operation and inform the manufacturer responsible for carrying out inspection.

7.5.2 Operate options

Details of specific operations can be found in the following sections:

- **Installation and first operation, page 21**
- **Maintenance, page 29**
- **Malfunctions, page 31**
- **Dismantling, page 33**

7.6 Emergency disengagement

Pull the lifting column's mains power cable from the socket.

NOTE

The lifting columns CPMA and CPMB do not have an on / off switch and must be disconnected from the power supply. Only this measure will de-energize the lifting columns.

NOTE

The application in which lifting columns CPMA and CPMB are installed, must provide an emergency stop switch or isolation from the mains supply on all conductors.

In hazardous situations, all movements of the device must be stopped as quickly as possible and the power supply turned off.

Procedure in hazardous situations:

1. Immediately engage emergency shut-off if present, or cut off power to lifting column.
2. Evacuate people from the hazard zone, initiate first aid measures.
3. Notify doctor and fire department, if necessary.
4. Notify responsible person on-site.
5. Keep access paths open for rescue vehicles.
6. Based on severity of emergency, notify other authorities if necessary.
7. Order specialized staff to repair malfunction.

⚠ WARNING

Do not restart until all persons are outside the hazard zone. Check the device and application that uses the device prior to restarting the operation and ensure that all safety equipment is installed and fully functional.

8. Check the device and the application that uses the device prior to restarting the operation. Ensure that all safety equipment is installed and fully functional.

7.7 Shut-down

1. Separate device from energy supply. Unplug the mains cables from the socket.
2. Ensure that the mains cables are not inadvertently plugged in again.

8. Maintenance

Personnel

- The maintenance work described here can be performed by the operator unless otherwise indicated.
- Some maintenance tasks should only be carried out by specially trained, qualified personnel, or exclusively by the manufacturer; This will be indicated in the description of the respective maintenance tasks.
- Only professional electricians should perform work on the electrical equipment.

⚠ WARNING

Electric shock hazard

Incorrect maintenance can result in serious injury, death or damage. Only professional electricians should work on electrical systems.

⚠ DANGER

Danger if restarted

When correcting faults, there is a risk of the energy supply being switched on without authorization. This poses a life-threatening hazard for persons in the danger zone.

Therefore:

Prior to starting repair work, switch off the system and be sure it is locked out.

NOTE

It is recommended that you comply with IEC 62353 regarding maintenance.

8.1 Maintenance plan

Maintenance tasks required for optimal and trouble-free operation are described in the sections below.

If increased wear is detected during regular inspections, shorten the required maintenance intervals according to the actual indications of wear.

NOTE

If the lifting column is used outside the environmental conditions specified earlier in this manual, check the device once a month for any changes, such as oxidation or sedimentation.

8.2 Maintenance work

The lifting columns CPMA and CPMB are maintenance-free for the duration of their operating life. (Details of operating life can be found in the appendix, see **Equipment and operating data, page 34**). Connection cables and housing must be checked for wear at regular intervals.

In compliance with applicable regulations, safety inspections must be carried out on location at regular intervals. Check grounding conductor resistance and substitute leakage currents annually.

8.2.1 Cleaning

⚠ WARNING

Electric shock hazard

Beware of damage to the lifting columns CPMA and CPMB caused by splashing or hose-directed water. The lifting columns CPMA and CPMB are, in accordance with IP20, not protected against splashing or hose-directed water. Exposure to this risk must be prevented at all times.

Observe the following points when cleaning:

- Separate device from energy supply. Unplug the mains cables from the socket. Lock out power.
- Clean soiled parts immediately
- Use a damp cloth
- Water used for cleaning, including added chemicals, must be pH-neutral
- Acidic or alkaline water can destroy metallic and synthetic parts

IMPORTANT: The lifting columns CPMA and CPMB must be installed with an application flat metal surface completely covering the outer tube base plate and another application flat metal surface completely covering the inner tube base plate. This will help protect against ingress of contaminants.

NOTE

Cleaning agents other than those listed, or use of high pressure steam cleaners will damage the lifting columns CPMA and CPMB. Always contact the manufacturer before using other cleaning agents.

8.2.2 Inspections and readings

- To be performed only by professional electricians.
- To be conducted according to the applicable standards and regulations.
- To be fully documented.

Complete the following entries in the service log:

- Name of the executing body (company, department)
- Names of the staff on duty
- Identification of the device/system (type, serial number, inventory number) and the respective accessories
- Completed inspections and readings
- Scope and results of the inspections
- Measuring method, measuring device, measuring results for readings
- Overall assessment / verification of all functions compared to specifications
- Date and signature of the assessor; personal coding is a viable alternative for IT applications.

IMPORTANT: Damage can be caused by incorrect cleaning

- Do not use aggressive cleaning agents. Water used for cleaning, including chemical additives, must be pH-neutral.
- The lifting column must not come in contact with any liquids during retraction or extension.
- Only use the auxiliary materials listed by the manufacturer.
- No steam jets or pressure washers to be used for cleaning.
- Use of other cleaning agents or devices only with the manufacturer's approval.

8.3 Measures following maintenance

Upon completion of the maintenance work, the following steps should be performed prior to restarting the device.

3. Check all previously loosened screw connections for a tight fit.
4. Ensure that all used tools, materials and other equipment have been removed from the work area.
5. Clean work area and remove potential spills such as liquids, processing materials or similar substances.
6. Ensure that all the system's safety measures are working satisfactorily.
7. Check all functions against the product specifications.
8. Document the inspections in the service log.

9. Malfunctions

This chapter describes potential causes for equipment malfunction and the work required to restore operation.

In the event of more frequent malfunctions, shorten the maintenance intervals.

For any malfunction not resolved using the information provided in this chapter, contact the manufacturer. See service contact details listed on www.ewellix.com.

Personnel

- Unless otherwise indicated, the work required to solve malfunctions may be performed by the operator.
- Some work may only be carried out by qualified personnel which is indicated in the description of the specific malfunction.
- Work on the electrical system may only be performed by professional electricians.

⚠ DANGER

Uncontrolled restart

When correcting faults, there is a danger of the energy supply being switched on without authorization. This poses a life-threatening hazard for persons in the danger zone.

Therefore:

- Prior to starting fault repair work, switch off the system and safeguard it by activating lockout.

⚠ WARNING

Risk of injury and device damage due to incorrect repair

Incorrect repair of a malfunction may lead to personal injury or device damage.

Therefore:

- Never loosen the screws on the lifting column or try to open the lifting column.
- If a malfunction that cannot be fixed by following the steps in the malfunction table (page 55), dismantle the device and send it to the manufacturer for repair (see **5.0 Transport, Packaging and storage, page 19**).

⚠ WARNING

Crush hazard

Risk of damage to the lifting columns CPMA and CPMB caused by static and dynamic overload of the lifting column. Do not use the lifting column beyond the permissible operating data.

- Note the maximum permissible operating data in the appendix (see **Equipment and operating data, page 34**)
- Note the product label of the lifting column.

Actions during malfunctions

9. In the event of a malfunction that may present an immediate danger to persons or assets, turn off the lifting column or control unit immediately and safeguard against a restart.
10. Be sure it is locked out.
11. Determine cause of malfunction.
12. Depending on the type of malfunction, have it repaired by qualified personnel.
13. Inform responsible party on-site concerning malfunction.

Homing procedure

The homing procedure can be requested from the control unit of the lifting columns CPMA and CPMB indicated by a blinking green LED on the operating device.

The homing procedure can be started by the technician simultaneously pressing the UP and DOWN buttons on the operating device for 5 seconds after switching on mains power until the green LED starts blinking.

The homing procedure retracts the lifting columns CPMA and CPMB to end position. The green LED will light permanently if the procedure is successful.

PLEASE NOTE: During the homing procedure only the mechanical end stop is available and the movement is at a reduced speed.

NOTE

The following malfunction table provides information as to the personnel authorized to perform the repair.

9.1 Malfunction table

Malfunction	Possible cause	To repair malfunction	To be repaired by
The lifting column is not functioning	No mains power connected	Check mains power connection	Professional electrician
	Poor plug contact	Ensure that the mains plug is inserted correctly or check the terminal connection	Professional electrician
	Mains cable defective	Replace mains cable	Professional electrician
	Operating device green LED is blinking	Operate homing procedure	Qualified personnel
	Operating device yellow LED is blinking	Repeat initial start up and homing procedure or return lifting column to Ewellix	Qualified personnel
	Operating device has no LED light	Check operating device connection	Qualified personnel
	Operating device defective	Replace operating device	Qualified personnel
The lifting column operates in only one direction	Motor stopped due to overheating	Wait 20 minutes and operate	Qualified personnel
	Motor defective	Return lifting column to Ewellix	Qualified personnel
	Lifting column reached internal stop	Operate in other direction	Operator
	When column blocked or overloaded, LED blinks 2 times yellow then green light again	Operate in opposite direction and try again. If error repeats, remove load and check if the movement of the application is unblocked.	Operator
	Operating device green LED is blinking	Operate homing procedure	Qualified personnel
Other devices connected to the lifting column are not functioning	Control unit defective	Operate homing procedure or return lifting column to Ewellix	Qualified personnel
	No mains power connected	Check mains power connection	Professional electrician
	Poor plug contact	Ensure that the mains plug is inserted correctly or check the terminal connection	Professional electrician
	Mains cable defective	Replace mains cable	Professional electrician
	Internal fuse of socket box outlet is defective	Replace with complying fuse 8 A (rated voltage 250 V AC, rated current 8 A, high breaking capacity)	Qualified personnel
	Internal fuse of socket box inlet is defective	Replace with complying fuse 8 A (rated voltage 250 V AC, rated current 8 A, high breaking capacity)	Qualified personnel
	Significant reduction in speed of movement	Motor, gearbox or nut defective	Return lifting column to Ewellix
Significant increase in noise during operation	Motor, gearbox or nut defective	Return lifting column to Ewellix	Qualified personnel
Significant backlash in guide tube unit	Wear in the gliding elements	Return lifting column to Ewellix	Qualified personnel

9.2 Start of operation after malfunction repair

After the malfunction has been repaired, perform the steps given under see **6.3 Installation, page 22** prior to restart.

10. Dismantling

Personnel

- Dismantling may only be performed by qualified personnel.
- Work on the electrical system may only be performed by professional electricians.

⚠ WARNING

Electric shock and moving parts hazards

Serious injury or death can be caused by touching live electrical components and by unexpected movement of the lifting column.

Be sure the system's power supply is off and the lifting column is locked out before installing.

⚠ WARNING

Risk of injury due to incorrect dismantling

Stored residual power, sharp-edged components, pins and corners on the individual components or on required tools can all cause serious injury.

Therefore:

- Ensure there is ample space for dismantling prior to starting the work.
- Use caution when working with open, sharp-edged structural components.
- Ensure order and cleanliness at the dismantling site. Loosely stacked structural components or structural components and tools on the floor increase risk of accidents.
- Dismantle structural components professionally in accordance with applicable local regulations.
- Secure structural components carefully to ensure they cannot fall or tip over.
- Contact Ewellix if you have any questions or concerns.

10.2 Disposal

Provided that no take-back or disposal agreement has been put in place, disassembled components should be recycled.

- Dispose of metals and plastic components at an appropriate recycling centre.

NOTE

Damage can be caused to the environment by incorrect disposal. Electronic waste, electronic components, lubricants and other additives are subject to special waste treatment regulations and may only be disposed of by approved specialized companies.

- Sort remaining components based on the respective materials and dispose of according to applicable local occupational health and environmental regulations. The local municipal authorities or specialized waste management companies can provide information concerning environmentally appropriate disposal.

10.1 Dismantling

1. Separate device from energy supply.
2. Secure elements of the application such that no loads can impact the lifting column.
3. Loosen and remove fastening bolts from the mounting of the lifting column.
4. Separate the lifting column from application elements.
5. Pull the plug of the operating device out of its corresponding terminal.
6. Clean the device.
7. Carefully package for shipment to the manufacturer.
8. For disposal, disassemble device according to applicable local occupational health and environmental regulations.

11. Appendix

This chapter enables the user to conveniently find technical data, directories, diagrams and plans.

11.1 Technical data

Equipment and operating data

The equipment and operating data can be found in the current data sheet.

- Data sheet for lifting column CPMA (PUB IL-07005-EN-October 2019)
- Data sheet for lifting column CPMB (PUB IL-07006-EN-October 2019)

Current data sheets are available on the Ewellix website (see ewellix.com).

Equipment and operational data overview (excluding reliability)

Technical data	Unit	CPMA1-1 / CPMB1-1	CPMA1-2 / CPMB1-2	CPMA2-2 / CPMB2-2
Rated push load (with self locking)	N	1 000	2 000	2 000
Rated pull load	N	0	0	0
Bending moment (dynamic)	Nm	up to 115 ¹⁾	up to 250 ¹⁾	up to 250 ¹⁾
Speed (full load to no load)	mm/s	14 to 15	11 to 15	11 to 15
Lifting column version	# of section	2-section	2-section	2-section
Stroke	mm	230 to 400	230 to 400	200 to 400
Retracted length	mm	S+160	S+160	S+160
Static load (Max) in push way	N	8 000	8 000	8 000
Static bending moment (Max)	Nm	500	500	500
Voltage (rated)	V	100-240 AC 50/60 Hz	100-240 AC 50/60 Hz	24 DC
input current (rated)	A	1,5	1,6	5
Duty cycle: intermittent operation	on/off	1 min./9min.	1 min./9min.	1 min./9min.
Ambient temperature	°C	+10 to +40	+10 to +40	+10 to +40
Type of protection	IP	20	20	20
protection class	–	I	I	–
Type of control	–	electrical	electrical	electrical
Noise level (Max)	dB(A)	45	45	45
Weight	kg	8 to 11	9 to 12	8 to 11
Stand by power (Max)	W	²⁾ to 2,1	²⁾ to 2,1	–

¹⁾ For details, see offset load diagrams

²⁾ The lowest value when powered with the lowest voltage

11.2 Plans and diagrams

To view the plans and diagrams, please contact Ewellix.
 Further information can be found in the data sheet.
 Current data sheets are available on the Ewellix website (see ewellix.com).

Electrical

Motor orientation

Figure 15

*Built-in with outer tube on top
 More easier to clean design*

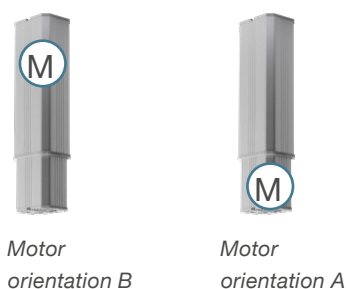
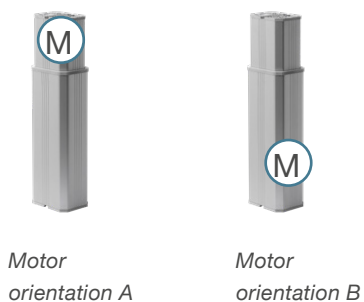

Figure 16

*Built-in with outer tube on bottom
 More aesthetic design*



Mains power, connection

Figure 17

Connecting diagrams

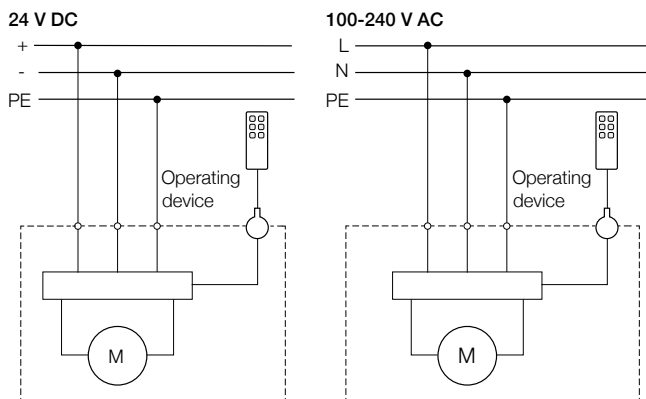

Construction of the desk switch and hand switch are shown in **fig. 18** and **fig. 19**. The foot switch has no LED.

Figure 18

Operating device, pin assignment for RJ45

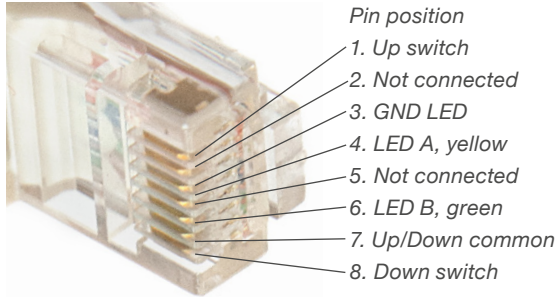
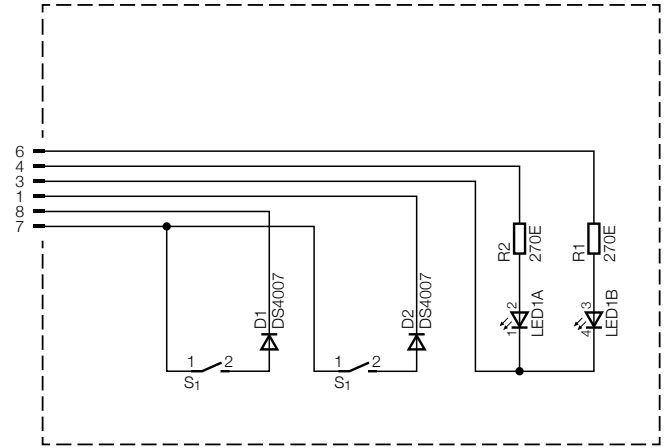

Figure 19

Connecting diagram



Mechanical (load)

CPMA1 and CPMA2 / CPMB1 and CPMB2

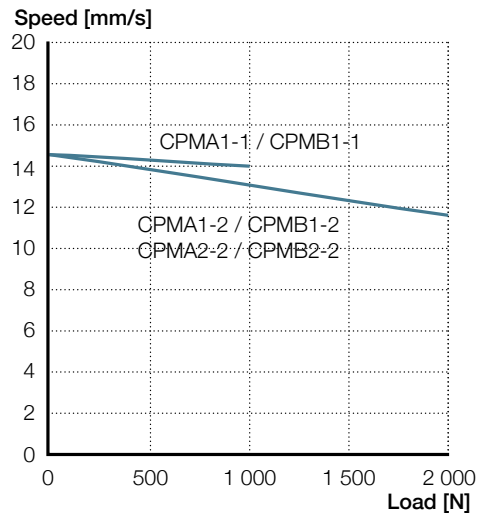

Offset load diagram – 300 mm stroke

CPMA1-1 / CPMB1-1

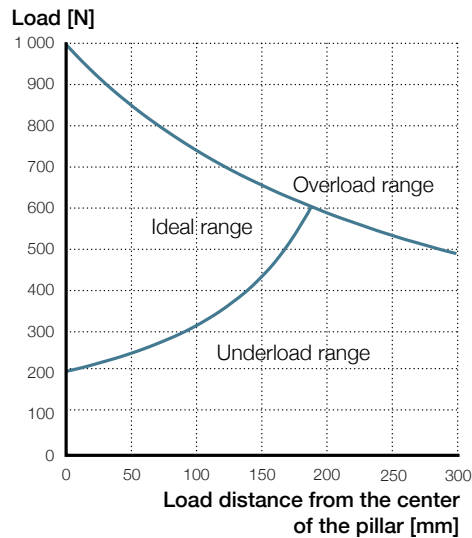

CPMA1-2 and CPMA2-2 / CPMB1-2 and CPMB2-2

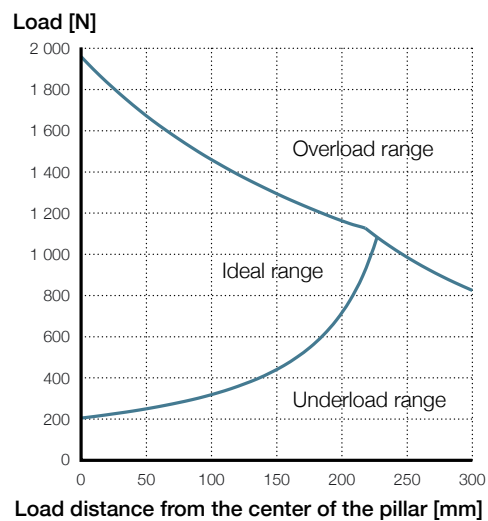

Offset load at full extension in the best axis

Dimensional drawing: lifting column with optional mounting plates, socket box inlet and socket box outlet.

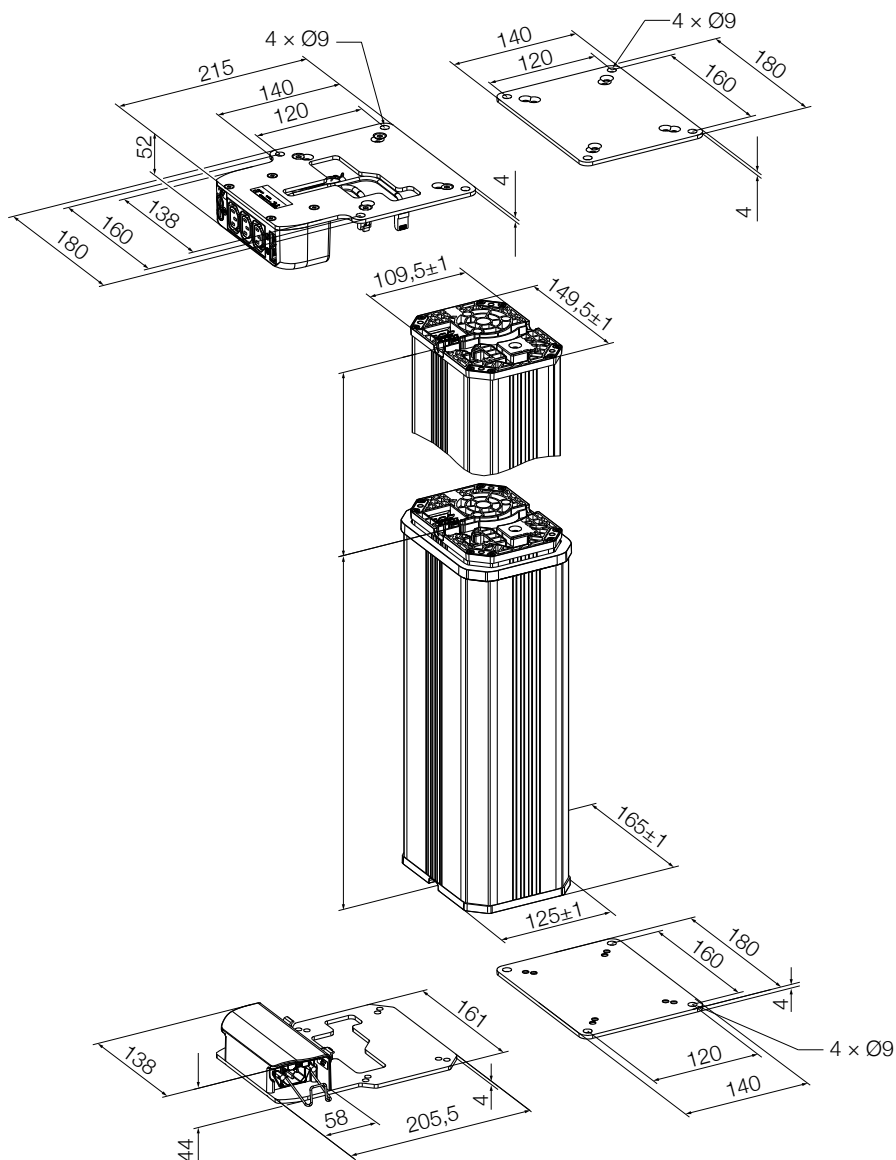

Fixing armatures available as accessory

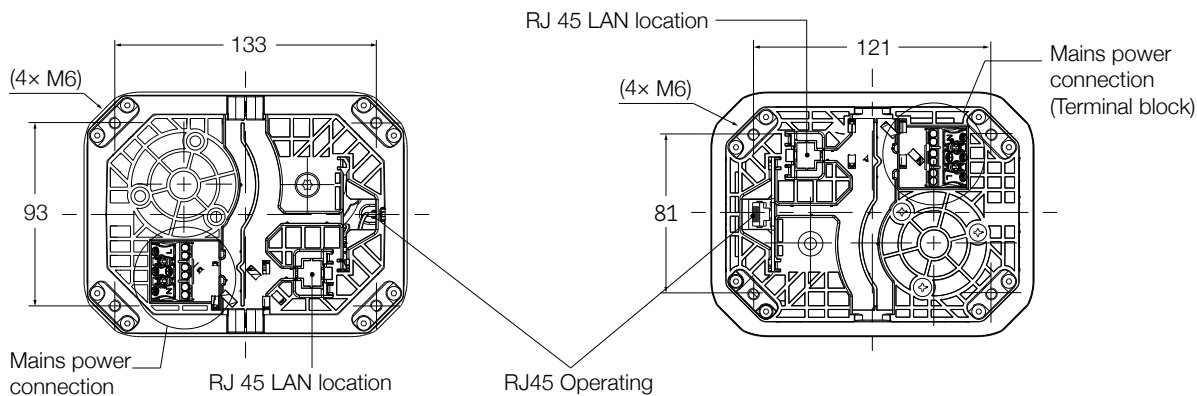

Column must be attached on plane and rigid surface by 4 screws M6 with a depth of 6 to 11 mm in the column. The total length of the screw must be adjusted to the height of the fixture.

Dimensional drawing: Desk switch

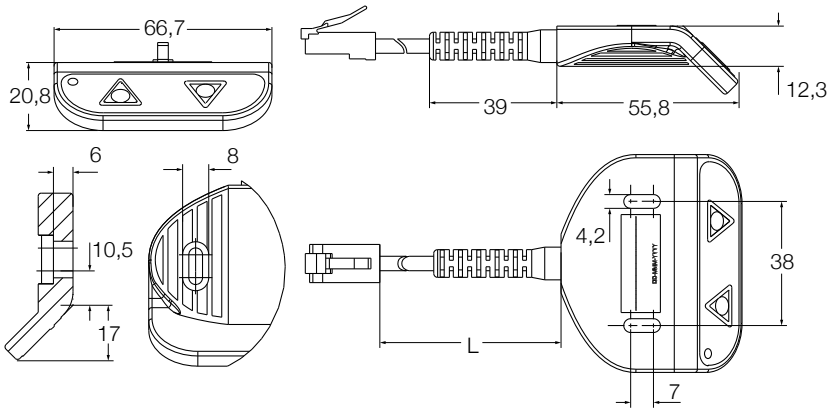

Dimensional drawing: Hand switch

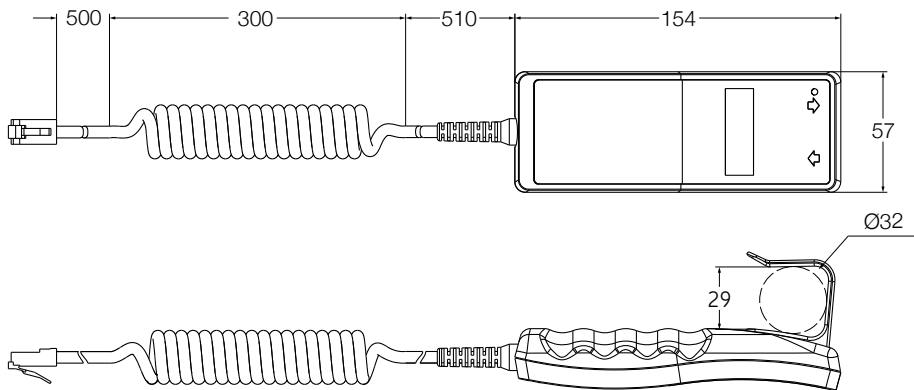

Dimensional drawing: Foot switch

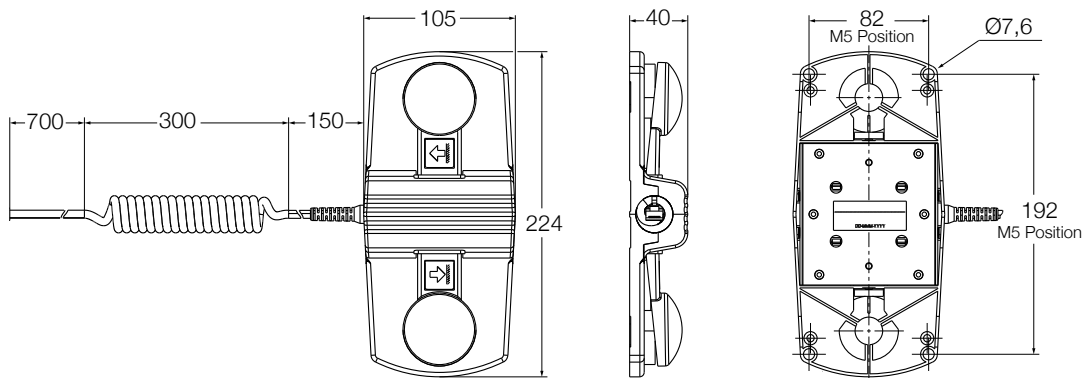

Ordering key

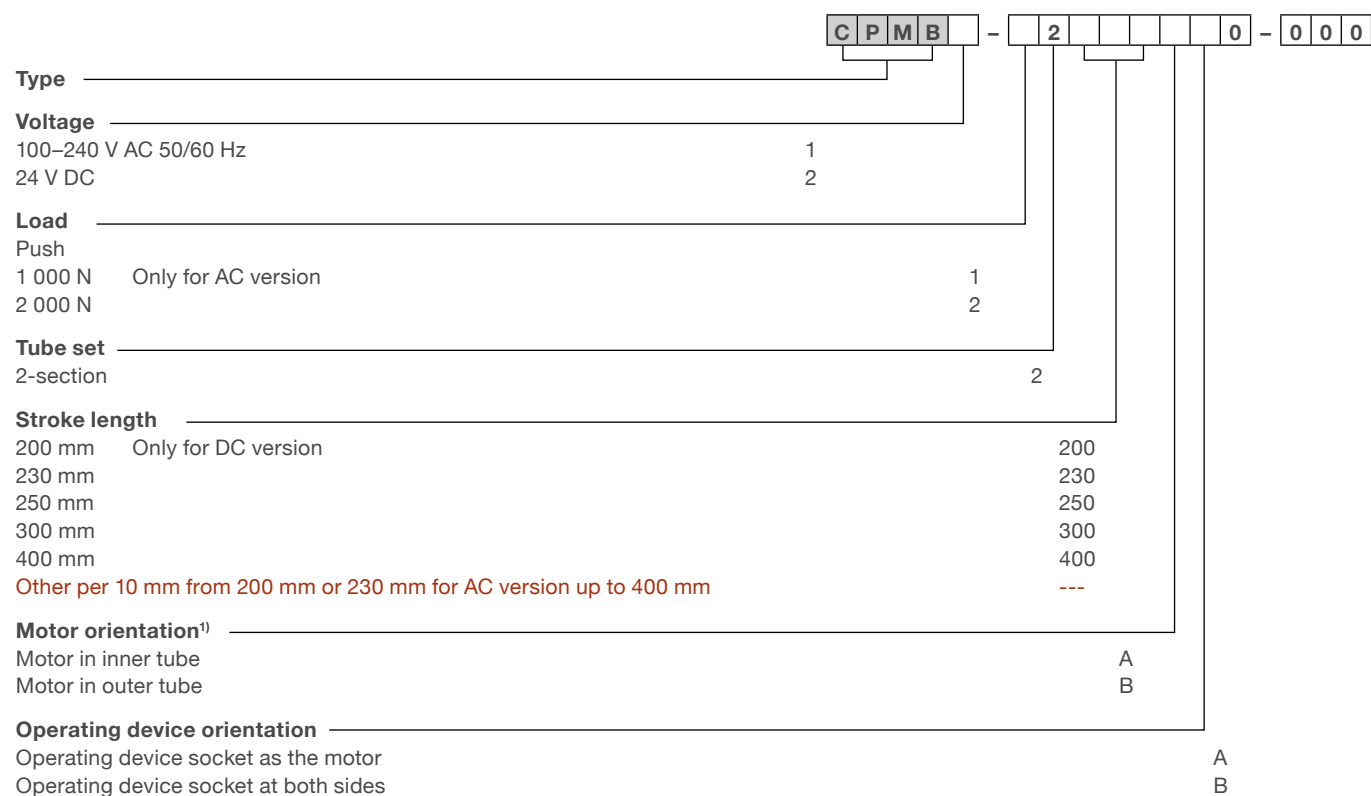
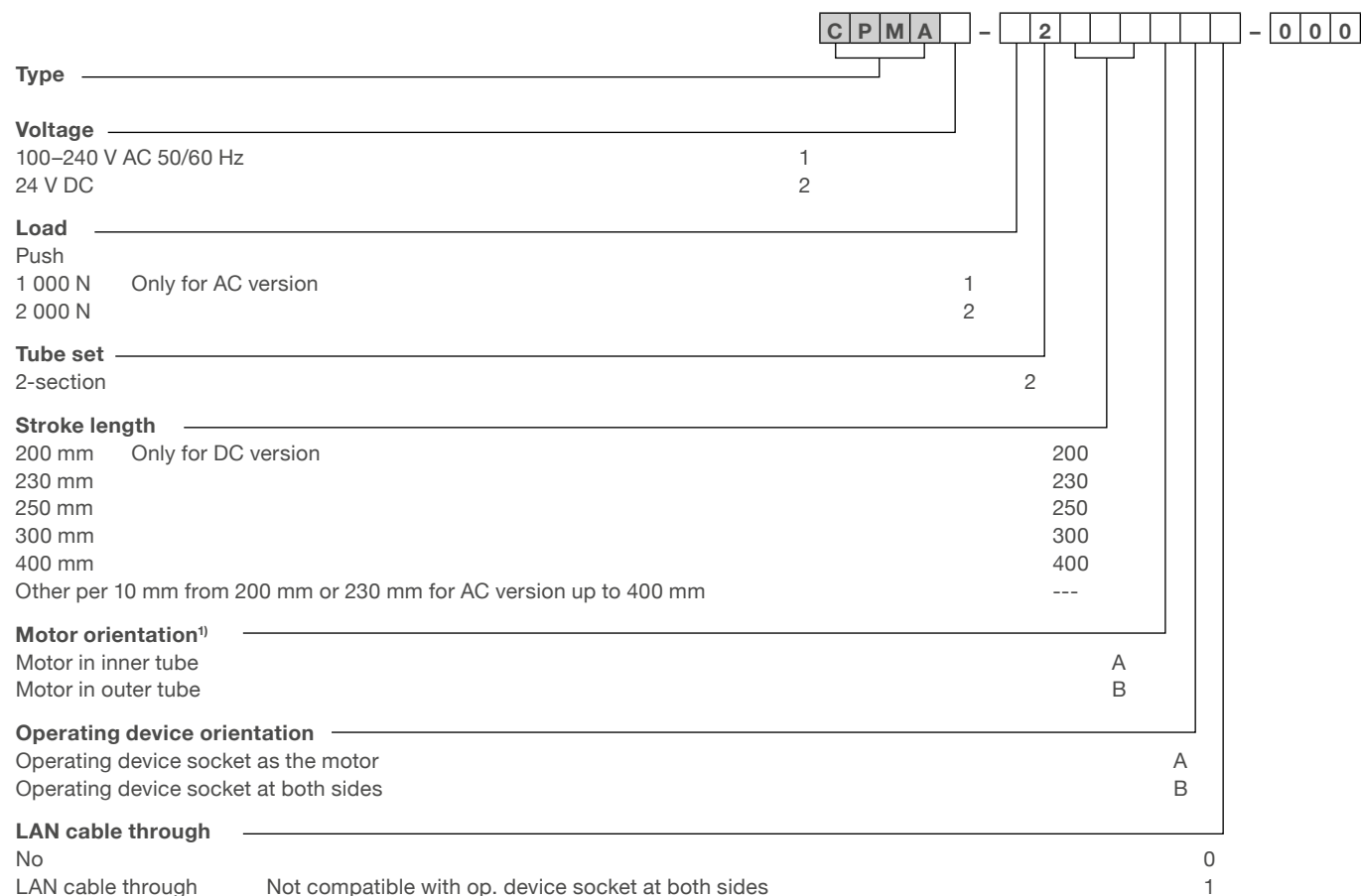

¹⁾ Column can be placed with outer tube on the top or bottom (see page 37)

11.3 Approved accessories

List of approved accessories

Table 1

Description	Plug	Country	Part number
Mains cable straight 2,5 m	Schuko	Germany, France, ...	ZKA-140449-2500
	Typ-L	Italy	ZKA-140450-2500
	British standard	UK	ZKA-140451-2500
	NEMA	USA, Japan, ...	ZKA-140452-2500
	SEV	CH	ZKA-140458-2500
	AS 3112	PRC, Australia, ...	ZKA-140460-2500
Detachable mains cord straight 2,5 m (to plug in socket box Inlet)	Schuko	Germany, France, ...	ZKA-140453-2500
	Typ-L	Italy	ZKA-140454-2500
	British standard	UK	ZKA-140455-2500
	NEMA	USA, Japan, ...	ZKA-140456-2500
	SEV	CH	ZKA-140459-2500
	AS 3112	PRC, Australia, ...	ZKA-140461-2500
Desk switch with LED, cable 0,5 m			STK01-SW3000-X100
Desk switch with LED, cable 1,0 m			STK01-UW3000-X100
Handset with LED, cable coiled 1,3 m			EHA41-13N00N-000
Foot switch, cable coiled 1,3 m			STL01-GW1000-X100
Mounting plate			ZPL-348382
Socket box inlet: IEC, RJ45 LAN, RJ45 op. device			ZDV-348220-002
Socket box outlet: 3xIEC, RJ45 LAN, RJ45 op. device			ZDV-348221-002

Mains cable straight 2,5 m

Mains cables with plugs for specific countries (see **table 1**) can be supplied as accessories. The mains cable is intended to be used in the base plate to facilitate the connection to the terminal mains feed through. Their specification is based on H05VV-F 3G1.5 (cable outside diameter 8,2 mm +/-0,5 mm, stranded wire with cross section 3x1,5 mm²). The end of the cable must be stripped 5-10 mm and the PE wire has to be 10 mm longer than mains cable neutral N and phase L.



Detachable mains cord straight 2,5 m

Detachable mains cords with plugs for specific countries (see **table 1**) and IEC-60320 C13 plug can be supplied as accessories. Intended to be used together with the socket box inlet.



Desk switch with LED cable 0,5 m or 1,0 m

The desk switch is defined as an operating device to be connected to lifting columns CPMA and CPMB and mounted below the tabletop.



Hand switch with LED cable coiled 1,3 m

The hand switch facilitates connection and control of the lifting columns CPMA and CPMB.



Foot switch without LED cable coiled 1,3 m

The foot switch facilitates connection and additional control of the lifting columns CPMA and CPMB.



Mounting plate

The purpose of the mounting plate is to ensure that the fastened application is seated fully and solidly. The outer tube base plate or inner tube base plate must be fastened to the mounting plate with four countersunk screws M6x12. The mounting plate must be fastened to the application with four fastening screws. The mounting plate is a flat metal plate supporting the force areas, and is in compliance with IEC/EN 60601-1-2.

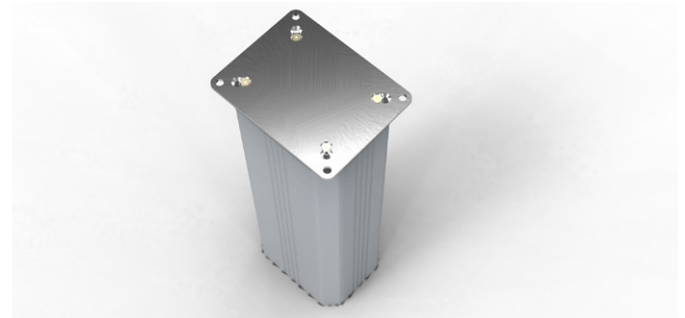

Socket box inlet: IEC, RJ45 LAN, RJ45 operating device

The socket box inlet facilitates connection for detachable mains cord with plug IEC-60320 C13 on one side, RJ45 LAN and RJ45 connection for operating device on the other side. It has an integrated flat metal plate. In the electrical circuit are two integrated fuses each for 8 A. The socket box inlet has to be connected to the terminal for mains feed through, RJ45 operating device terminal, RJ45 LAN terminal, and be mounted between the base plate of the lifting columns CPMA and CPMB and the elements of the application. The outer tube base plate or the inner tube base plate must be fastened to the application with four fastening screws.



The socket box inlet is used to conduct current through the lifting column CPMA and CPMB. The current through is available during a movement of the lifting column (see diagram).

NOTE

The current can be used to power equipment through the lifting column. The current through should be reduced depending on the ambient temperature (see graph below).

Upper current limit for cable through

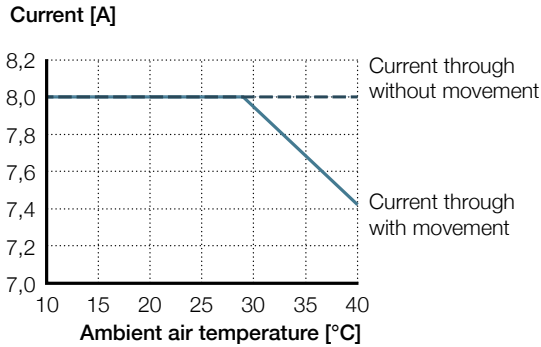

IMPORTANT: The fuses are replaceable and must be replaced according to the following specification: fuses T 8 A H (rated voltage 250 V AC, rated current 8 A, high breaking capacity).



Socket box outlet: 3×IEC, RJ45 LAN RJ45 operating device

The socket box outlet is comprised of a multiple outlet socket with three connections for mains cord with plug IEC-60320 C14, one RJ45 LAN and one RJ45 connection for operating device. It has an integrated metal mounting plate. In the electrical circuit are two integrated fuses each of 8 A. The socket box outlet must be connected to the terminal for mains feed through, RJ45 operating device terminal, RJ45 LAN terminal and be fastened with delivered four counter-sunk screws M6 on the base plate of the lifting columns CPMA and CPMB. The application must be fastened to the mounting plate of the socket box with four fastening screws.

IMPORTANT: The fuses must be replaced only with fuses 8 A complying (rated voltage 250 V AC, rated current 8 A, high breaking capacity).

11.4 CE – Declaration

Declaration of incorporation according to annex IIB of Directive on machinery 2006/42/EC can be supplied upon request.



ewellix.com

© Ewellix

All contents of this publication are the property of Ewellix, and may not be reproduced or given to third parties (even extracts) without permission. Although great care has been taken in the production of this catalog, Ewellix does not take any responsibility for damage or other loss resulting from omissions or typographical errors. The photo may differ slightly in appearance from the actual product. Due to continuous improvements being made in our products, the product's appearance and specifications are subject to change without notice.

PUB TC-08015/2-EN-Februar 2025

Schaeffler and the Schaeffler logo are trademarks of the Schaeffler Group.