

EWELLIX

MAKERS IN MOTION

INSTALLATION, OPERATION AND
MAINTENANCE MANUAL

CPSM

Servo pillar



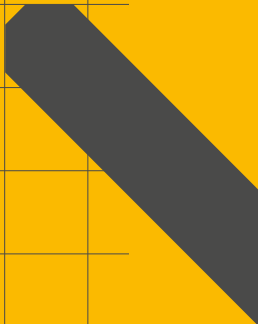
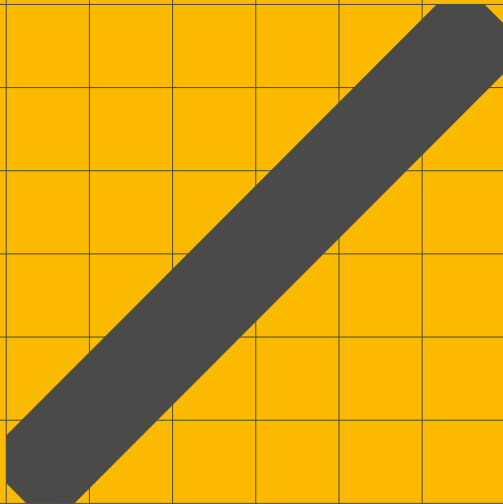

Contents

1.0 General information	4	7.0 Operation	21
1.1 Information in this manual	4	7.1 Safety	21
1.2 Explanation of symbols and signal words	4	7.2 Turn on	21
1.3 Limitation of liability	5	7.3 Turn off	21
1.4 Copyright	5	7.4 Actions before use	21
1.5 Spare parts	5	7.5 Actions during the operation	22
1.6 Warranty terms	5	7.6 Emergency disengagement	22
1.7 Customer service	5	8.0 Maintenance	23
2.0 Safety	6	8.1 Maintenance plan	23
2.1 Use	6	8.2 Maintenance work	23
2.2 Responsibility of the owner and processor	7	8.3 Measures following completed maintenance	24
2.3 Personnel requirements	7	9.0 Malfunctions	25
2.4 Specific dangers	8	9.1 Malfunction table	26
2.5 Safety equipment	8	9.2 Start of operation after	26
2.6 Safeguard against restart	8	10.0 Dismantling	27
2.7 Modifications of device	8	10.1 Dismantling	27
3.0 Technical data	9	10.2 Disposal	27
3.1 Ambient conditions	9	11.0 Appendix	28
3.2 Product label	9	11.1 Technical data	28
4.0 Structure and function	10	11.2 Plans and diagrams	29
4.1 Overview	10		
4.2 Brief description	11		
4.3 Special features	12		
4.4 Requirements for motor, control unit and power supply	12		
4.5 Connections	13		
4.6 Operating elements	13		
4.7 Options	13		
5.0 Transport, packaging and storage	14		
5.1 Delivery inspection	14		
5.2 Return to the manufacturer	14		
5.3 Packaging	14		
5.4 Storage	15		
6.0 Installation and first operation	16		
6.1 Installation location	16		
6.2 Inspections prior to initial operation	16		
6.3 Installation	17		
6.4 Connection to the control unit	20		
6.5 Connection to power supply	20		
6.6 Initial start-up	20		

WARNING

Read this manual before installing, operating or maintaining this actuator. Failure to follow safety precautions and instructions could cause actuator failure and result in serious injury, death or property damage.

1.0 General information

1.1 Information in this manual

This manual provides important information on how to work with the actuator (also called the device) safely and efficiently. The Manual is part of the device, must always be kept and should be available for personnel to read at any time. All personnel working with the device must read and understand this manual before starting any work. Strict compliance with all specified safety notes and instructions is a basic requirement for safety at work.

Moreover, the accident prevention guidelines and general safety regulations applicable at the place of use of the device must also be complied with.

For better representation of circumstances, the illustrations in this manual are not necessarily to scale and may vary from the actual design of the device.

All information and notes in this manual were compiled with due consideration given to applicable standards and regulations, the present status of technology and our years of knowledge and experience.

1.2 Explanation of symbols and signal words

Safety precautions

Safety precautions are identified by symbols and signal words defined on the right hand side of this page. These signal words indicate the severity of the hazard.

Adhere to these safety precautions and take caution in order to avoid accidents that may result in personal injuries or damage to property



NOTE

Emphasizes useful hints and recommendations as well as information for efficient and trouble-free operation.

NOTICE

Indicates a dangerous situation, which can lead to minor or moderate property damage, if the precautionary measures are ignored.

CAUTION

Indicates a dangerous situation, which can lead to minor or moderate injury, if the precautionary measures are ignored.

WARNING

Indicates a dangerous situation, which can lead to serious personal injury or death, if the precautionary measures are ignored.

DANGER

Indicates a dangerous situation, which will lead to death or serious personal injury, if the precautionary measures are ignored.

1.3 Limitation of liability

All information and notes in this manual were compiled under due consideration of valid standards and regulations, the present status of technology and our years of knowledge and experience.

The manufacturer will not be liable for damage resulting from:

- Disregarding this manual
- Unintended use
- Employment of untrained personnel
- Unauthorized conversions
- Technical modification
- Manipulation or removal of the screws on the device

Where the device has been customized, the actual product delivered may be different from what is described in this manual. In this case, ask Ewellix for any additional instructions or safety precautions relevant to these actuators.

We reserve the right to make technical modifications to the actuator to improve usability

1.3.1 Validity

The instructions in this manual refer to the telescopic pillar CPSM with the following identification:

- Manufacturer: Ewellix
- Product name: Telescopic pillar CPSM
- Type designation: CPSM10–BN–10–abbbb–cdd–ee–fff
- Year of manufacture: start from 2018

Where the device has been customized by Ewellix, the actual product delivered may be different from what is described in the manual. In this case, ask Ewellix for any additional instructions or safety precautions relevant to these.

We reserve the right to make technical modifications to the device units to improve usability.

1.4 Copyright

This manual is protected by copyright law and to be used exclusively by Ewellix customers internal purpose

Passing this manual on to third parties, duplication of any kind – even in the form of excerpts – as well as the use and/or disclosure of the contents without the written consent of the manufacturer is not permitted, except for internal purposes.

Violation of Ewellix's copyright may become the subject of a future claim for damages.

1.5 Spare parts

This actuator is not designed for repair work. All warranty and service claims become void without notice if any screws on the linear actuator have been manipulated.

⚠ WARNING

Safety hazard caused by use of non-genuine spare parts

Wrong or faulty spare parts can adversely affect safety and cause serious injury, damage, malfunction or total failure. Therefore:

- Spare parts in/on the device may only be replaced by the manufacturer.

If the device cannot be repaired on site by authorized personnel it must be dismantled and sent to the manufacturer.

1.6 Warranty terms

The applicable and effective warranty terms are those contained in the manufacturer's terms and conditions of sale contained in the Ewellix sales contract that governs this sale.

1.7 Customer service

Ewellix Customer Service is always available to provide technical information and to answer questions.

The contact information for Ewellix Customer Service can be found on www.ewellix.com.

2.0 Safety

2.1 Use

This section provides an overview of important safety aspects of installing, operating and maintaining this device. Disregarding this manual and safety regulations specified therein may result in considerable danger and possible serious injury or death or damage to device or equipment.

WARNING

Risk from misuse

Any utilization of this device beyond its intended purpose may lead to potentially hazardous situations.

Therefore:

- Strictly adhere to all safety precautions and instructions in this operating manual.
- Do not allow this device to be subjected to weather conditions, strong UV rays, corrosive or explosive air media as well as other aggressive media.
- Do not modify, retool or change the structural design or individual components of the linear module.
- Never use the device outside of the technical application and operational limits described in this manual.

2.1.1 CPSM pillar intended use

The telescopic pillar CPSM has been designed and built to be operated in accordance with its intended use.

- The telescopic pillar CPSM is designed to lift dynamically centric and/or off-centric loads in vertical direction.
- The telescopic pillar CPSM is designed to be used for continuous operation at high speed
- Note: The performance is dependent on the motor selection. The limiting values must not be exceeded. (↳ **4.4 Requirements for motor, control unit and power supply, page 12**)
- The telescopic pillar CPSM is designed for height adjustments of applications in the industrial segment. Any other use of this device must be authorized by the manufacturer.
- The telescopic pillar CPSM is only suitable for indoor applications and may not be exposed to the outdoors, heavy UV radiation or dusty, corrosive or explosive environments.

If you use the telescopic pillar CPSM for any use other than that cited, the manufacturer cannot be held responsible for any resulting damage or injury.

2.1.2 Product life time

The product life time of the telescopic pillar CPSM depends on the stroke, the load and the cycle of the application.

Please ask the manufacturer to calculate and provide the L10 lifetime of the telescopic pillar CPSM for the specific application case.

2.1.3 Unintended use

Any use other than the intended use, or modifications to the device without the manufacturer's written agreement, or operation beyond the technical limits, is considered unauthorized.



NOTE

Any unauthorized use of the device can cause personal injury and property damage. Always adhere to the instructions given in this manual.

2.2 Responsibility of the owner and processor

The device is designed for commercial applications by its owner or processor.

The processor is the contracting partner of the reseller or the manufacturer.

The processor installs the device in a complete system (application).

The owner or processor of the system is therefore subject to the requirements of the Occupational Health and Safety Act. In addition to the safety instructions in this manual, the owner or processor must do the following concerning these safety and accident prevention guidelines and environmental protection regulations applicable to the site of the system's installation:

Inform themselves of applicable industrial safety regulations. They must also determine additional hazards that arise due to the specific working conditions prevailing at the site where the device is installed using risk assessment. The risk assessment must be implemented in the form of work instructions for device operation.

- Confirm that the work instructions created for the system, including the device satisfy current legal requirements and must alter the instructions accordingly.
- Clearly regulate and specify the responsibilities for installation, operation, maintenance, and cleaning.
- Ensure that all employees who deal with the device have read and understood this manual.
- Provide personnel with the required protective equipment.
- Provide training for personnel at regular intervals and inform personnel of the hazards.

In addition, the owner or processors must ensure that the device is in adequate working condition. They must do the following:

- Ensure that the maintenance intervals described in these instructions are complied with.
- Have all safety devices inspected regularly for function and completeness.

2.3 Personnel requirements

⚠ WARNING

Improper installation, operation and maintenance can result in serious injury, death or property damage.

Use only qualified, trained personnel (as described below) who have read, understand and follow these instructions.

2.3.1 Qualifications

The following qualifications are specified for different areas of activity listed in this manual:

- **A trained person (Operator)**
Instructed by the customer in an orientation session on the assigned tasks and possible dangers arising from in case of improper behavior.
- **Qualified personnel**
Based on their professional training, know-how and experience as well as knowledge of the applicable standards and regulations are able to independently perform assigned work activities and to detect and avoid possible dangers.
- **Professional electrician**
Based on their professional training, know-how and experience as well as knowledge of the applicable standards and regulations are able to independently perform work on electrical systems and to detect and avoid possible dangers. In addition, the professional electrician has been trained for the special location where they work and know the relevant standards and regulations.

Only persons who can be expected to perform their tasks reliably are permitted as personnel. Persons whose reaction capabilities are impaired, e.g. through the use of drugs, alcohol or medication for example, are not permitted.

2.4 Specific dangers

The following section lists the residual risks that have been determined by a risk assessment.

The manufacturer has constructively, and with protective measures, minimized the effects of existing hazards. Pay attention to the residual hazards and potential countermeasures described and the warnings in the following chapters.

⚠ WARNING

Risk of injury from moving parts

Moving parts may cause serious injuries.

Therefore:

- Do not reach into moving parts or touch moving parts during operation.

⚠ WARNING

- The end user has to ensure that the motor/signal cables are properly secured and strain-relieved.
- The control unit is provided by the end user and is not part of the scope of delivery from Ewellix.
- The telescopic pillar CPSM may be damaged if liquids penetrate inside the pillar. Keep liquids away!
- The end user has to ensure that an emergency switch is installed in the application to stop in case of emergency any motion of the telescopic pillar CPSM immediately.
- The end user has to ensure that a person or an object can be released in any case of emergency; i.e. the operation of the telescopic pillar CPSM must be guaranteed in case of power loss with appropriate means.
- The end user must prevent any unintended motion of the telescopic pillar CPSM in their application.
- The motor and signal cables must be laid and fixed in a clean and safe way to prevent them from any damage during operation

2.5 Safety equipment

⚠ WARNING

Danger due to malfunctions safety equipment

For safe operation, be sure all features are in good working order.

Therefore:

- Always check functionality of safety equipment according to the maintenance plan.
- Never disengage safety equipment.
- Safety equipment may never be bypassed or modified.

Integration of an emergency-stop system required (for certain applications)

The device is only intended for installation into an application or system. It does not have its own operating control elements

and does not have its own emergency-stop-function.

Install the device so that it is part of an emergency shut-off system and can be stopped if necessary.

The emergency shut-off system has to be connected in such a way that a disruption of the power supply or the reactivation of the power supply after a power disruption cannot cause a hazardous situation for persons and objects.

The emergency shut-off system must always be easily accessible.



NOTE

The processor must decide which applications require the installation of an emergency shut-off system.

2.6 Safeguard against restart

⚠ WARNING

Life-threatening situation through unauthorized restart!

For work in hazard zones, there is a risk that the power supply will be turned on without prior authorization. This presents a life-threatening situation for people in the hazard zone.

Therefore:

- Follow the information concerning safeguarding against restarting of the power supply in the chapters of this operating manual.
- Always follow the process to safeguard against a restart as described below.

2.7 Modifications of device

⚠ WARNING

To avoid hazardous situations and to ensure optimal performance, do not make any changes or modifications to the device unless they have been specifically authorized by Ewellix.

2.7.1 Warning labels

The symbol below can be found on the motor or power supply near the hot surface.



Hot surfaces can cause burns and should not be touched. Protection must be provided against accidental contact if necessary.

WARNING

Danger because of illegible symbols

Over the course of time stickers and decals may become dirty or illegible for some other reason.

Therefore:

- Keep any safety, warning and operation related decals in legible condition at all times
- Replace damaged decals or stickers immediately

3.0 Technical data

The technical data of the telescopic pillar CPSM can be found in the Appendix.

(↳ 11.0 Technical data, page 28).

3.1 Ambient conditions

- Temperature range: +10 to +40 °C
- Atmospheric humidity: 5% to 85%
- Non-condensing
- Atmospheric pressure: 700 to 1060 hPa

The telescopic pillar CPSM is suitable for indoor use only and must not be exposed to weathering, strong UV radiation or corrosive or explosive atmospheric media.

3.2 Product label

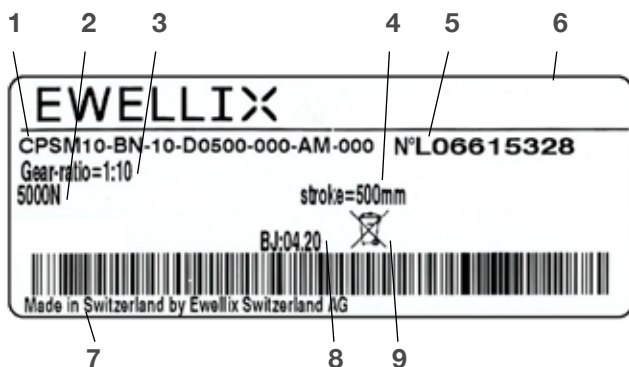

The Product label provides the following information

1. Type designation
2. Centric load
3. Gear Ratio
4. Stroke
5. Serial number
6. Manufacturer-specific company name
7. Manufacturer-specific barcode and address
8. Date of manufacture (month/year)
9. Disposal

4.0 Structure and function

This chapter is intended for all users of telescopic pillar CPSM and describes the basic design and function of the device.

4.1 Overview

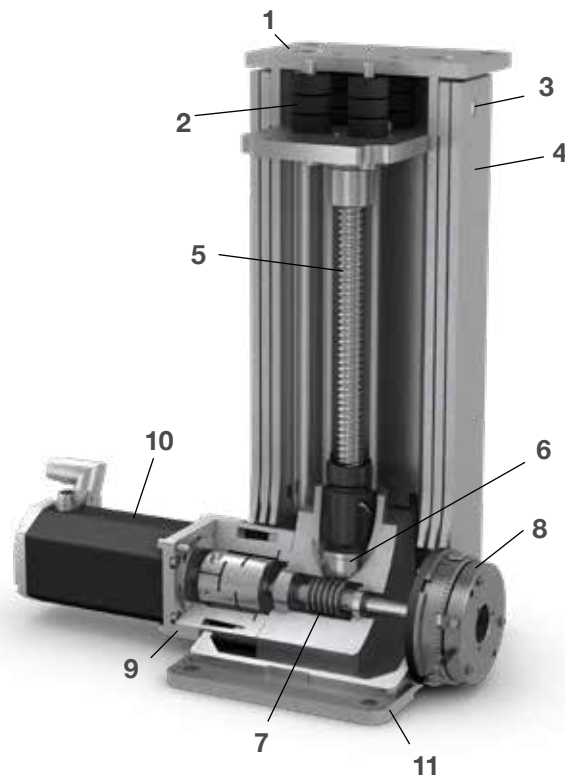

1. Customized top plate
2. Optional damping system
3. Backlash-free long lasting guiding pads
4. 2 or 3 section extruded aluminum guiding tubes
5. High efficiency ball screw
6. Preloaded bearing arrangement
7. Low friction worm gear reduction
8. Optional electromechanical brake
9. Standard or customized motor interface
10. Motor (Brushless DC or servo AC)
11. Customized bottom plate

4.2 Brief description

A description of its function enables better understanding of what the telescopic pillar CPSM and their individual parts do.

4.2.1 Functional principles

The functional principle of the telescopic pillar CPSM is based on a pushing force for the lifting of centric as well off-centric loads.

A flange mounted motor (preferably a Brushless DC Motor or a Servo Motor) (1) drives a ball screw (2) via a coupling (3) and a worm gear (4). The ball screw is supported in the gear housing (5) with a taper bearing (6) and is rotating accordingly, the complete drive unit its mounted to the bottom plate (7). A ball screw nut (8), which is attached to the push tube (9), moves up and down on the ball screw. The push tube is mounted to the top plate (10). Optionally a shock absorber (11) (damping element) can be mounted between the push tube and the top plate. The telescopic tubes (12) extend and retract depending on the rotational direction of the motor. The motor in combination with the control accelerates/decelerates the movement or holds the tube position at a standstill. The telescopic pillar CPSM design offers to mount an electromechanical holding brake (13) on the motor shaft (14).

Motor / control unit

The telescopic pillar CPSM is designed to mount a wide range of motor options and brands. This feature allows the customer to choose their preferred motor and controller equipment. The standard interface of the telescopic pillar CPSM can be equipped with a customized motor adapter to ensure the correct fit.

(↳ **4.4 Requirements for motor, control unit and power supply, page 12**).



NOTE

Ewellix is not responsible for the setup of the motor/control unit.

End position

The telescopic pillar CPSM does not provide any means to limit the stroke. The end user is responsible to choose appropriate equipment to limit the up / down motion of the pillar.

The telescopic pillar CPSM is equipped with mechanical end stops to restrict the travel in the event of failure.



NOTE

Damage may occur to the pillar and/or application if the mechanical end stop is reached.

Mounting plates

The top and bottom base plate of the telescopic pillar CPSM show four regular through holes for M10 size bolts. Its purpose is to fasten the telescopic column on either side to the application. The top/bottom plates are attached permanently with counter sunk fastening screws M10 to the inner/outer tube.



NOTE

The counter sunk fastening screws must not be removed under any circumstances!

Guiding tube unit

The guiding tube unit is made up of either two sections or three sections. Its purpose is to carry eccentric loads.

The tubes are adjusted to each other with gliding pads.

The outer tube is located in the lower position, the inner tube is located in the upper position. The middle tube of the 3-section unit is not synchronized, it is free floating, its position is depending on the predominant friction.

The outer surface of the tubes are clear anodized – other colors are available on special request.

4.3 Special features

Drive unit

The motor is powered from an external control unit/ power supply. It drives the ball screw via the worm gear. The use of a ball screw ensures high number of cycles. The speed of the movement is variable in both directions and can be adjusted via the parametrization of the control unit. The parametrization of the control unit must be done by the end user.

Worm gear

The worm gear transfers the motion from the horizontal axis to the vertical axis. On the input side the gear shaft is driven by the electric motor whereas the worm wheel drives the ball screw on the output side.

The standard gear ratio is 10, on special request the ratio can be changed.

Electromechanical brake

The electromechanical brake is located on the extended worm shaft. Its purpose is to release the motor when the telescopic pillar CPSM reached its position. With this option the duty cycle can be increased and / or the motor size can be reduced. Also it adds additional safety to the system.

Technical data

Information Unit	Value	Unit
Brake torque	10	Nm
Coil voltage	24	VDC
Power consumption	24	W



Shock absorber

The shock absorber is an optional feature that is mounted in between the ball screw unit and the top plate. It protects the inner parts of the servo pillar CPSM in case of hard impacts. This might be helpful for applications where goods are loaded on the top of the pillar and could create high peak loads.

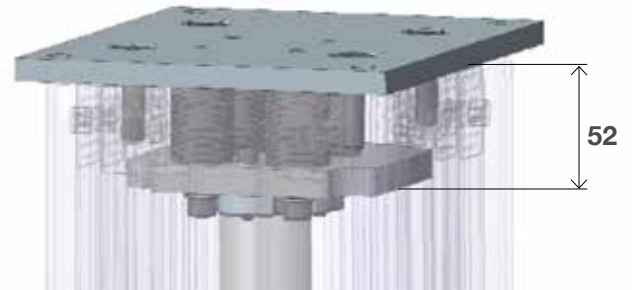

NOTE

The retracted length increases by 52 mm.

4.4 Requirements for motor, control unit and power supply

In principle, all motors that are equipped with an axial shaft may be fitted with the telescopic pillar CPSM.

It is important that the rated power of the motor does not exceed the permitted values of the telescopic pillar:

Technical data

Information Unit	Value	Unit
Continuous force at max speed	5	kN (dynamic)
Max permissible gear input speed	6 000	rpm

The relevant power supply and the control unit must be provided by the end user.

Ewellix recommends to use the following motors

- **SIEMENS 1FK07034-2AK71-1UH0**
nominal values: torque 1.00 Nm / speed 6 000 rpm
- **DUNKERMOTOREN BG75X75 PI**
nominal values: torque 1.16 Nm / speed 3 700 rpm

Additional information regarding the installation of alternative motors can be found in the section (↳ **6.3 Installation, page 17**).

NOTE

Ewellix is not liable for any damage of equipment and/or injury of person.

4.5 Connections

The telescopic pillar CPSM provides the following connections:

Top/bottom plate

The telescopic pillar CPSM is fitted with a rectangular steel plate (size 170 mm x 220 mm, strength 10 mm) at the top and bottom side. Each plate provides 4 regular through holes for M10 size bolts to attach the device to the application. The hole pattern measures 140 mm x 190 mm.

The plates are fixed with 4 counter sunk fastening screws M10 to the relevant tube.



NOTE

The counter sunk fastening screws must not be removed under any circumstances!

Motor interface

The design offers tailor-made solutions in order to attach customer's preferred motor to the pillar (↳ **6.3 Installation, Motor interface, page 17**).

4.6 Operating elements

Ewellix does not provide operating elements for the telescopic pillar CPSM. Any operating elements must be provided from the end user!

4.7 Options

The telescopic pillar CPSM offers the following standard options:

- Shock absorber (↳ **page 12**)
- Electromechanical brake (↳ **page 12**)
- Customized motor adapter (↳ **6.3 Installation, motor interface, page 17 and 19**).

5.0 Transport, packaging and storage

⚠ CAUTION

Material damage due to improper transport

Improper transport may cause transported items to fall down or topple over. This may cause costly material damage.

Therefore:

- Proceed carefully during the unloading of the packaged items during delivery as well as during the transport to its final destination. And comply with the symbols and information shown on the packaging.
- Only remove device from packaging right before installation.
- Note terms and conditions for storage for any return transport to the manufacturer.

5.1 Delivery inspection

The telescopic pillar CPSM is delivered as one packaged unit in a box or on pallets. Check the delivery immediately upon receipt of the delivery, for completeness and any signs of damage incurred during transport.

Check scope of delivery:

- A complete unit with all packaged parts present
- Accessories (coupling; motor adapter, screws etc.)

Check delivery for transport damage:

- Unpack upon receipt.
- Check the telescopic pillar CPSM for damage, dents and scratches.

If exterior transport damage is evident:

- Do not accept delivery or accept with exceptions.
- Record scope of damage on the transport documents or bill of delivery of the shipping company.
- Initiate complaint.



NOTE

Report any damage as soon as it has been recognized. Damage claims can only be asserted within the transporter's applicable complaint period.

5.2 Return to the manufacturer

Proceed as follows for any return shipment:

1. Uninstall the pillar if necessary (↳ **10.1 Dismantling, page 27**)
2. Pack device in its original packaging. Follow storage conditions (↳ **5.4 Storage, page 15**)
3. Send pillar to manufacturer. Contact Ewellix service to obtain a shipment address.

5.3 Packaging

Requirements:

The individual packaged pieces have been packaged appropriately for the expected transport conditions. Only environmentally-friendly materials were used for the packaging.

The packaging is supposed to protect the individual components from transport damage, corrosion and other damage prior to installation. Therefore, do not destroy the packaging and only remove the device shortly prior to installation. Keep package for potential return shipment to the manufacturer.

If the packaging is to be disposed of following satisfactory delivery, please note and adhere to the following:



NOTE

Packaging material consists of valuable raw materials, much of which can effectively be recycled and reused.

Therefore:

- Dispose of packaging material in an environmentally correct way.
- Comply with locally applicable disposal regulations.

5.4 Storage

For storage, pack the telescopic pillars CPSM in its original packaging. Observe the following values when selecting a storage location:

- Do not store outside
- Dry and dust-free storage
- Keep away from any aggressive media
- Protect from UV radiation
- Avoid mechanical vibrations
- Storage temperature: -20 to +60 °C
- Atmospheric humidity: max. 85%, non-condensing
- Pressure: 700 to 1060 hPa

For storage longer than three months, check the general condition of all parts of the packaging on a regular basis.



NOTE

There may be notices on the packaging concerning additional storage requirements not listed here, if so, follow these accordingly.

6.0 Installation and first operation

This chapter is intended for technicians and those involved with further processing. It provides the information needed to assemble, connect and start up the telescopic pillar CPSM. Qualification (↳ **2.3.1 Qualifications, page 7**)

Authorized personnel

The installation and first start of operation may only be conducted by qualified personnel.

Work on the electrical system may only be performed by professional electricians.

⚠ WARNING

Electric shock and moving parts hazards

Serious injury or death can be caused by touching live electrical components and by unexpected movement of the telescopic pillar.

Be sure the system's power supply is off and the telescopic pillar is locked out before installing.

⚠ WARNING

Danger if restarted

When correcting fails there is a risk of the energy supply being switched on without authorization: This poses a life threatening hazard for persons in the danger zone.

Therefore:

- Prior to starting work, switch off the system and be sure it is locked out.

⚠ WARNING

Installation adjacent to other equipment

The device should not be installed adjacent to or stacked with other equipment. If adjacent or stacked use is necessary, the device should be trialed under observation, to verify normal operating in the configuration in which it will be used.

⚠ WARNING

Special precautions regarding EMC

The device requires special precautions regarding EMC and must be installed and put into service according to the EMC information provided in this operating manual (↳ **2.0 Safety, page 6**)

⚠ WARNING

Risk of injury and device damage due to incorrect installation of the optional device

Therefore:

- Optional devices, in particular components that are part of a retrofit, may only be installed in accordance with their respective instructions (circuit diagram).
- Electromagnetic compatibility must be tested for the routing and appropriate corrective measures carried out if necessary.

6.1 Installation location

- Adhere to the technical data for operating conditions.
- Install in a location according to the ambient operating conditions and where the devices are not exposed to strong UV radiation or corrosive or explosive air media (↳ **3.1 Ambient conditions, page 9**).

6.2 Inspections prior to initial operation

Prior to first operation, a professional electrician must perform and document the following tests and reading:

- Visual condition check.
- Function check of operating features and safety features.



NOTE

- Additional information concerning inspections and readings (↳ **8.0 Maintenance, page 23**).

6.3 Installation

Erection and alignment

The following points must be kept in mind as regards the erection and alignment of the device.

Make sure that

- The device cable cannot be bent or squashed.
- The connecting cables between actuators, control units and operating elements cannot get crushed or squashed.

Interfaces and connections

The interfaces at the top and bottom side of the telescopic pillar CPSM as well as the connection interface for the motor are described in the following paragraph:

⚠ WARNING

Risk of injury and material damage due to insufficient fastening!

Only use fastening screws with property class 10.9.
Always secure them adequately.
Never loosen or remove screws on the actuator.



NOTE

Fastening screws are not supplied. Further instruction can be found in the following sections Top interface and Bottom interface.
Please ensure that the screws cannot inadvertently become loose.

Bottom interface

The telescopic pillar CPSM is fitted with a rectangular steel plate (size 170 mm x 220 mm, strength 10 mm) at the bottom side (→ **fig. 1**). It provides 4 regular through holes for M10 size bolts to attach the telescopic pillar CPSM to the application base. The dimension of the hole pattern shows 140 mm x 190 mm.

Please observe the following values and advice:

- Minimum screw in depth 25 mm
- Screw tightening torque 40 Nm
- Only use screw with a property class of 10.9
- Consider plate strength of 10 mm when choosing the bolt length.
- Check that all screws are sufficiently secured so that they do not loosen on their own.

Fig. 1

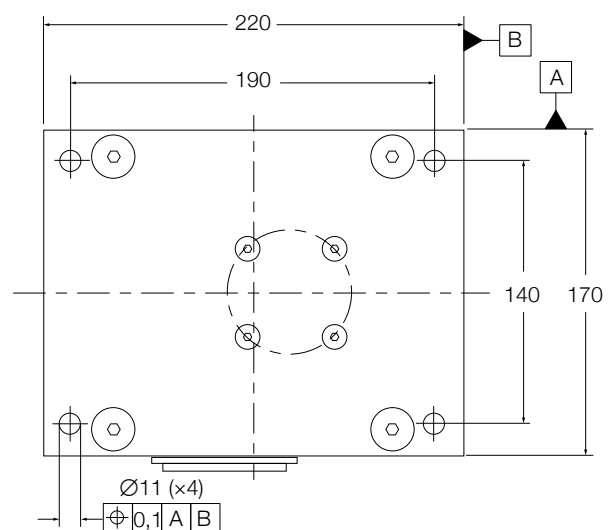

Top interface

The telescopic pillar CPSM is fitted with a rectangular steel plate (size 170 mm x 220 mm, strength 10 mm) at the top side (↳ **fig. 2**). It provides 4 regular through holes for M10 size bolts to attach the telescopic pillar CPSM to the application top side. The dimension of the hole pattern shows 140 mm x 190 mm.

Please observe the following values and advice:

- Minimum screw-in depth 25 mm
- Screw tightening torque 40 Nm
- Only use screw with a property class of 10.9
- Consider plate strength of 10 mm when choosing the bolt length.
- Check that all screws are sufficiently secured so that they do not loosen on their own.

Fig. 2

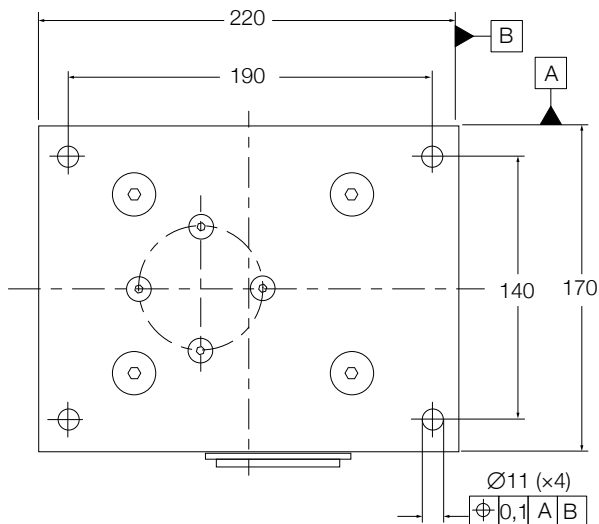

WARNING

Risk of injury from moving parts!

While driving onto solid objects, the force of the device may cause injuries. In the retracted end position, there is a risk of crushing between parts of the pillar.

Therefore:

- When retracting ensure that no objects or body parts can be caught between the attachment plate (1) of the inner tube and the outer tube (2).
- When retracting ensure that no objects or body parts can be caught between the attachment plates (1) and (3).
- If there is a risk of injury, depending on the installation location, a mechanical safety device must be installed.

Fig. 3

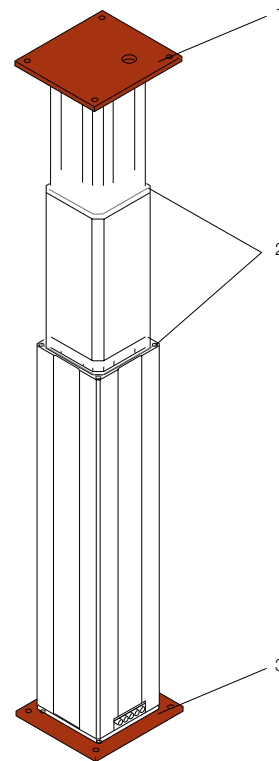

WARNING

Risk of injury and material damage due to excessive load! Overloading the pillar can destroy the device which can lead to serious injuries or property damage.

Therefore:

- With excentric loads, take note of the load diagram (↳ **11.1 Technical data, page 28**) or contact the manufacturer.

NOTE

Malfunctions due to scratching!

Scratching the side surfaces of the tubes can lead to malfunctions during operation.

Therefore:

- During installation, ensure that the tube side surfaces are not scratched.

Pillar installation procedure

Please adhere to the following installation procedure:

1. Connect both the top plate and bottom plate to the elements of the application with attachment screws.
2. Ensure that the minimum screw-in depth and screw tightening torques are complied with (↳ [page 17](#) and [18](#)).
3. Ensure that all screws are sufficiently secured so that they do not loosen on their own.
4. Ensure that the telescopic pillar is not hindered in its movement anywhere in the lift area. Consider collision tests of the application.
5. When retracting, ensure that no objects or body parts can be caught. Between the attachment plate of the inner tube and the outer tube (↳ [fig. 3, page 18](#)).
6. Ensure that the motor cable cannot be crushed, pinched or pulled.
7. Connect the telescopic pillar CPSM to the control (not provided from Ewellix).
8. Connect the control to the power supply (not provided from Ewellix).
9. Ensure that the power plug of the control is accessible at all times.
10. Ensure that none of the supply or control cables can be pinched by motions of the application or by the telescopic pillar during the extension or retraction.
11. Extend the pillar.

Motor interface

The telescopic pillar CPSM can be fitted with any motor with an axial shaft that are within the following parameters:

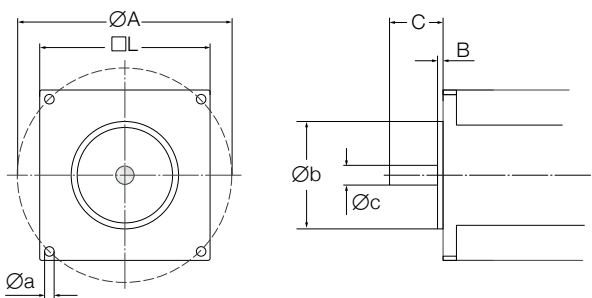

	Symbol	Min.	Max.
Motor housing	□ L	60	95
Fixing diameter	Ø A	52	103
Motor centering	Ø b	47	95
Centering height	B	1	5
Shaft diameter	Ø c	11	19
Shaft length	C	15	48

NOTE: The rated power of the motor must not exceed the permitted values of the telescopic pillar CPSM (↳ [4.4. Requirements for motor, control unit and power supply, page 12](#)).

Motor installation procedure

If the motor adapter plate / motor is not pre-mounted from Ewellix please adhere to the following procedure:

1. Install the motor adapter plate to the coupling housing.
2. Secure the adapter plate with the 4 flat head cylinder screws (M6 x length) provided by Ewellix.
3. Tightening torque 10.1 Nm (↳ [Table 1](#))
4. Install the coupling hub on the motor shaft and align as indicated in [Table 2, page 20](#).
5. Tighten the screw of the coupling hub.
6. Tightening torque 8 Nm (↳ [Table 1](#))
Note: The other coupling hub incl. the elastomer insert always is factory pre-mounted on the gear shaft.
7. Align the two coupling hubs and insert the motor into the centering of the motor adapter plate.
8. Secure motor with screws provided from Ewellix or select appropriate screws to fix motor to motor plate.
9. Consider thickness of adapter plate and motor flange when choosing the screw length.
10. Tighten the fastening screws of the motor.
11. Tightening torque 10.1 Nm (↳ [Table 1](#))

Table 1

Screw tightening torque

Screw size	for motor adapter (1+2)	for coupling (3)
M4	3.0 Nm ±0.3	
M5	5.9 Nm ±0.8	8 Nm ±0.8
M6	10.1 Nm ±0.8	

Fig. 5

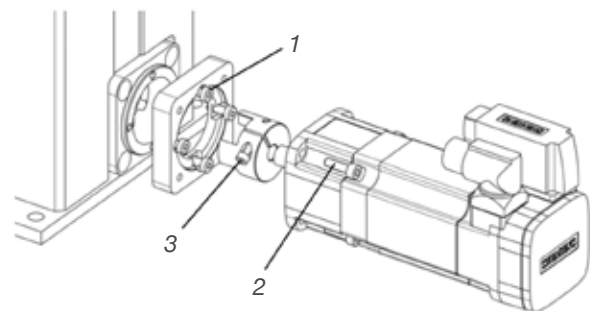
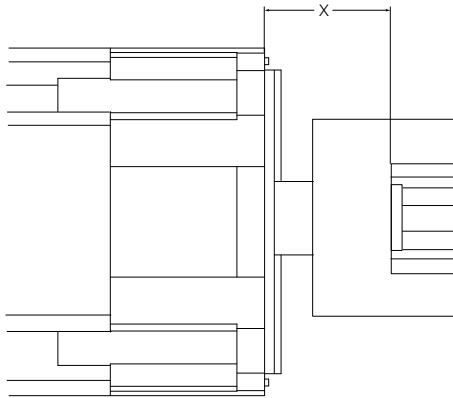

Table 2

Position of coupling hub on motor shaft



Motor	Distance X
Siemens 1FK7034	22,6 mm
Dunker BG75	27,6 mm
Any other	Ewellix provides the correct value with delivery

6.4 Connection to the control unit

The control unit is not provided by Ewellix, it's the end user's responsibility to described the preferred procedure it in the end user's manual for the application.

NOTE

The device does not feature its own control unit. The operation takes place via a separate control unit (see separate operating manual).
unit. Follow the Ewellix control unit's operating manual instructions during the connection process.

6.5 Connection to power supply

The power supply is not provided by Ewellix, it's the end user's responsibility to described the preferred procedure it in the end user's manual for the application.

NOTE

The device does not feature its own control unit. The operation takes place via a separate control unit (see separate operating manual).

6.6 Initial start-up

Installation check

Before initial start-up, check that the following precautions have been taken care of:

- All instructions followed in the above sections of this chapter.
- All cables secured against pinching and trapping, and properly connected.
- Electrical supply secured; i.e. motor power cable and signal cable.
- connected to the control unit.
- No persons or obstacles near any movement.
- Grounding conductor resistance and substitute leakage currents checked according threshold of owner usage.
- 4 x M10 fastening screws secured on bottom side and tightened with predefined torque.
- 4 x M10 fastening screws secured on top side and tightened with predefined torque.
- Entire stroke area unobstructed so that telescopic pillars CPSM cannot be driven onto a fixed object.

Initial start-up

After the installation check has been completed, you can start up the device, the system.

Make sure that all functions are correctly operational.

7.0 Operation

7.1 Safety

⚠ WARNING

Crush hazard

While moving onto solid objects, the force of the device may cause injuries.

Therefore:

- Ensure that there are no persons in the stroke area of the device while in operation.
- Take note of maximum permissible operating parameters for device (↳ **Appendix, Technical data, page 28**).
- Do not touch elements connected to the device while the device is in operation.

⚠ DANGER

If a part of the linear module fails (belt breaking, screw fracture, loss of input torque), the working mass will drop.

Therefore:

- Additional safety features must be in place to protect the workplace.
- When there is no input torque, the pillar can be moved manually or by gravity. A motor with fail safe brake is highly recommended, particularly for vertical application.
- Check the drive regularly for signs or excessive wear (↳ **8.2 Maintenance work, page 23**).

⚠ CAUTION

Material damage due to static and dynamic overload of the device

Static and dynamic overload can lead to damage and failure of device.

Therefore:

- Adhere to maximum permissible operating parameters for the device (↳ **Appendix, Technical data, page 28**).
- Never exceed nominal load.

⚠ WARNING

Burn hazard. Do not touch running actuator, i.e. motor which gets hot.

NOTICE

Actuator may be damaged if liquids penetrate the actuator during extension and retraction. Keep liquids away.

NOTICE

Material damage through overheating

An overheating of the device can cause damage.

Therefore:

- Only use control integrated thermal switch.

7.2 Turn on

After the installation and first operation, a comprehensive function check should be done before operation, by activating the corresponding functions via the connected operating element.



NOTE

The device does not feature its own operating control elements. The operation takes place through separate operating element (↳ **Separate operating manual**).

7.3 Turn off

After operation the telescopic pillar CPSM can be switched off acc. to the procedure described in the end user's manual for the application.

Preferably the telescopic pillar is in lower retracted position when the system is turned off.



NOTE

The device does not feature its own operating control elements. The operation takes place through separate operating element (↳ **Separate operating manual**).

7.4 Actions before use

Ensure that there are no person or object in the stroke area of the device!

NOTICE

Contamination of the devices can cause serious damage. Therefore:

- Clean dirty parts immediately after they became dirty (↳ **8.2.1 Cleaning, page 24**).

7.5 Actions during the operation

The telescopic pillars CPSM has been designed for continuous operation.

It is important that the rated power of the motor does not exceed the permitted values of the telescopic pillar (↳ **4.4 Requirements for motor, control unit and power supply, page 12**).

Under normal operation, telescopic pillar CPSM lifts or lowers elements connected to the telescopic pillars via the top and bottom plate.



NOTE

The device does not feature its own operating control elements. The operation takes place through separate operating element (see **separate operating manual**).

⚠ CAUTION

Excessive current consumption, unusual noise or an unwanted movement from the actuator indicate damage or defect of the control unit.

Therefore:

- Cease operation and contact the manufacturer immediately.

7.6 Emergency disengagement

Push the emergency shut-off switch that must be provided in the application of the end user!

In hazardous situations, all movements of the application must be stopped as quickly as possible and the power supply turned off.

7.6.1 Shut down

Proceed as follows in hazardous situations:

1. Immediately engage emergency shut-off.
2. Evacuate people from the hazard zone, initiate first aid measures.
3. Notify doctor and fire department if necessary.
4. Notify responsible person on-site.
5. Keep access paths open for rescue vehicles, order specialized staff to repair malfunction.
6. Based on severity of emergency, notify the authorities if necessary.
7. Order specialized staff to repair malfunction.

⚠ WARNING

Do not restart until all persons are outside the hazard zone. Check the device and application that uses the device prior to restarting the operation and ensure that all safety equipment is installed and fully functional.

8. Check the device and application that uses the device prior to restarting the operation. Ensure that all safety equipment is installed and fully functional.

8.0 Maintenance

Personnel

- The maintenance work described here can be performed by the operator unless otherwise indicated.
- Some maintenance tasks should only be carried out by especially trained, qualified personnel, or exclusively by the manufacturer. This will be indicated in the description of the respective maintenance tasks.
- Only professional electricians should perform work on the electrical equipment.
- Only professional trained personnel can substitute any electrical equipment, accessories and cables.

WARNING

Electric shock hazard

Incorrect maintenance can result in serious injury, death or damage. Only professional electrical systems.

DANGER

Danger if restarted

When correcting faults, there is a risk of the energy supply being switched on without authorization. This poses a lifethreatening hazard for persons in the danger zone.

Therefore:

- Prior to starting repair work, switch off the system and be sure it is locked out.

NOTE

It is recommended that you comply with IEC 62353 regarding maintenance.

8.1 Maintenance plan

Maintenance tasks that are required for optimal and trouble-free operation are described in the sections below.

If increased wear is detected during regular inspections, shorten the required maintenance intervals according to the actual indications of wear.



NOTE

If the telescopic pillar is used outside the environmental conditions specified earlier in this manual, check the device once a month for any changes, such as oxidation or sedimentation.

8.2 Maintenance work

The telescopic pillar CPSM is maintenance-free for the duration of the product life time (↳ **2.1.2 Product life time, page 6**).

Connection cables and housing must be checked for wear and tear at regular intervals. In compliance with applicable regulations, safety inspections must be carried out on location, at regular intervals. Check grounding and substitute leakage currents annually.

Every six months, the device must be checked by monitoring the telescopic pillar CPSM as it retracts and extends. The following points have to be checked regularly:

- Plug
- Housing
- Cable
- Protection earth
- Leakage current
- Function

This regular check includes checking of all functions and safety measurements.

8.2.1 Cleaning

Clean the device as soon as possible to prevent any accretion of unwanted material

NOTICE

Damage due to incorrect cleaning

Therefore:

- Do not use any aggressive cleaning agents. Water used for cleaning, including chemical additives, must be pH-neutral.
- Liquids must not touch the pillar during retraction or extension.
- Only use the auxiliary materials listed by the manufacturer.
- No steam jets or pressure washers may be used for cleaning.
- Other cleaning agents or cleaning devices may only be utilized with the manufacturer's approval.

Cleaning instruction:

1. Separate device from the energy supply.
2. Clean soiled parts with a damp cloth.



NOTE

Wash water in use, including added chemicals, must be pH-neutral.

Acidic or alkaline wash water can destroy metallic and synthetic parts.



NOTE

Cleaning agents other those listed, or use of high pressure steam cleaners will damage the telescopic pillar CPSM. Always contact manufacturer before using other cleaning agents.

8.2.2 Inspections and readings

- To be performed by a professional electrician.
- To be conducted according to the applicable standards and regulations.
- To be fully documented.

Complete the following entries in the service log:

- Name of the executing body (company, department).
- Names of the staff on duty.
- Identification of the device/system (type, serial number, inventory number) and the respective accessories.
- Completed inspections and readings.
- Scope and results of the inspections.
- Measuring method, measuring device, measurement results for readings.
- Overall assessment / verification of all functions compared to specifications.
- Date and signature of the assessor; personal coding is a viable alternative for IT applications.

8.3 Measures following completed maintenance

Upon completion of the maintenance work, the following steps should be performed prior to restarting the device:

- Check all previously loosened screw connections for a tight fit.
- Ensure that all used tools, materials and other equipment have been removed from the work area.
- Clean work area and remove potential spills such as e. g. liquids, processing materials or similar substances.
- Ensure that all the system's safety measures are working satisfactorily.
- Check all functions against the product specifications.
- Document the inspections in the service log.

9.0 Malfunctions

This chapter describes potential causes of equipment malfunction and the work required to restore operation. In the event of more frequent malfunctions, shorten the maintenance intervals.

For any malfunction not resolved using the information provided here, contact the manufacturer. See service contact details listed on www.ewellix.com or the back cover.

Personnel

- Unless otherwise indicated, the work required to solve malfunctions may be performed by the operator.
- Some work may only be carried out by qualified personnel, which is indicated in the description of the specific malfunction.
- Work on the electrical system may only be performed by professional electricians.

DANGER

Uncontrolled restart

When correcting faults, there is danger of the energy supply being switched on without authorization. This poses a lifethreatening hazard for persons in the danger zone.

Therefore:

- Prior to starting fault repair work, switch off the system and safeguard it by activating lockout.

WARNING

Risk of injury and device damage due to incorrect repair

Incorrect repair of a malfunction may lead to personal injury or device damage.

Therefore:

- Never loosen the screws on the device or try to open the device
- If a malfunction cannot be fixed by following the steps in the malfunction table below, dismantle the device and send it to the manufacturer for repair (↳ **Transport, Packaging and Storage**)

Actions during malfunctions

1. In the event of a malfunction that may present an immediate danger to persons or assets, turn off the actuator or control unit immediately and safeguard against a restart.
2. Be sure the pillar is locked out.
3. Determine cause of malfunction.
4. Depending on the type of a malfunction, have it repaired by qualified personnel.
5. Inform responsible party on-site concerning malfunction.



NOTE

The following malfunction table provides information as to the personnel authorized to perform the repair.

9.1 Malfunction table

Malfunction	Possible cause	To repair malfunction	To be repaired by
The telescopic pillar does not move	Control unit not operational	Check mains power connection to control unit	Professional electrician
		Ensure that the operating device is connected correctly to the control unit	Qualified personnel
		Ensure that the current limit of the control unit matches the requirements defined in this manual	Qualified personnel
		Consult the operating manual of the control unit	Qualified personnel
	Operating device defective	Replace operating device	Qualified personnel
		Consult the operating manual of the operating device	Qualified personnel
	Poor connector contact to control unit	Ensure that the connector is inserted correctly into the control unit	Operator
	Incorrected load	Ensure that the load of the pillar does not exceed the load limit in the technical specification	Qualified personnel
	Obstacle in the stroke area of the device	Remove all obstacles in the stroke area	Operator
	Cable defective	Check cable for squeezing, tearing or other damage	Professional electrician
	Motor has stopped due to high temperature safety shut off	Observe duty cycle in technical specification. Wait 20 minutes and try again.	Qualified personnel
	Device cannot be set in motion by any of the suggested repair measures	Contact Ewellix service	Qualified personnel
Lifespan of the drive is exceeded	Contact Ewellix service	Qualified personnel	
The telescopic pillar only operates in one direction	Telescopic pillar reached external end limit switch	Operate in the other direction	Operator
	Control unit malfunction	Consult operating manual of control unit	Qualified personnel
	Operating device malfunction	Consult operating manual of operating device	Qualified personnel
	Obstacle in the stroke area of the device	Remove all obstacles in the stroke area	Operator
The telescopic pillar stops before reaching its maximum stroke	Control units cuts off power	Ensure the centric and eccentric load does not exceed the load limits given in the specification	Qualified personnel
	Obstacle in the stroke area of the device	Remove all obstacles in the stroke area	Operator
Significant reduction in speed of movement	Incorrect load	Ensure that the load of the pillar does not exceed the load limit in the technical specification	Qualified personnel
		Remove all obstacles in the stroke area	Operator
	Motor, gearbox nut or external brake defective	Contact Ewellix service	Qualified personnel
	Incorrect voltage set	Ensure the correct voltage is set	Qualified personnel
Significant increase in noise during operation	Incorrect load	Ensure that the load of the pillar does not exceed the load limit in the technical specification	Qualified personnel
	Obstacle in the stroke area of the device	Remove all obstacles in the stroke area	Operator
	Motor, gearbox nut or external brake defective	The pillar must not continue to be operated. Contact Ewellix service	Qualified personnel
Play in the guiding system	Sliding elements are worn	Replace driving unit	Qualified personnel
Drive unit vibrations during movement	Incorrect service load	Ensure that the load of the pillar is in the optimal range (no over- or underload) as defined in the technical specification	Qualified personnel
	Wear or failure of the external brake	Contact Ewellix service	Qualified personnel

9.2 Start of operation after

To restart device following repair of the malfunction, perform the steps described in chapter 6.3 Installation, page 17.

10.0 Dismantling

This chapter is intended for technicians and those carrying out further processing. It provides all the information needed for removal the devices from service, including dismantling and disposal.

Personnel

- Dismantling may only be carried out by specifically qualified personnel.
- Work on the electrical system may only be performed by professional electricians

WARNING

Electric shock and moving parts hazards

Serious injury or death can be caused by touching live electrical components and by unexpected movement of the telescopic pillar.

Be sure power supply is off and telescopic pillar is locked out before dismantling.

WARNING

Risk of injury due to incorrect dismantling

Stored residual power, sharp-edged components, pins and corners on the individual components or at the required tools can cause serious injuries.

Therefore:

- Ensure there is ample space for dismantling prior to starting with the work.
- Use caution when working with open, sharp-edged structural components.
- Ensure order and cleanliness at the dismantling site! Loosely stacked structural components or tools on the floor may present a source for accidents.
- Dismantle structural components professionally pursuant to applicable local regulations.
- Secure structural components in a way so they will not be able to fall or tip over.
- Contact the manufacturer if you have any questions or concerns.

10.1 Dismantling

1. Separate the telescopic pillar device from energy supply.
2. Secure elements of the application such that no loads can impact the telescopic pillar.
3. Loosen and remove fastening bolts from the mounting plates of the telescopic pillar.
4. Separate the telescopic pillar from application elements.
5. Pull the plug of the operating device out of its corresponding terminal.
6. Clean the device.
7. Carefully package for shipment to the manufacturer.
8. For disposal, disassemble the telescopic pillar according to applicable local occupational health and environmental regulations.

10.2 Disposal

Provided that no take-back or disposal agreement has been put in place, the disassembled components should be recycled.

- Dispose of metals and plastic components at an appropriate recycling center.



NOTE

Damage can be caused to the environment due to incorrect disposal

Electric waste, electronic components, lubricants and other additives are subject to special waste treatment regulations and may only be disposed of by approved specialized companies.

- Sort remaining components based on the respective materials and dispose of according to applicable local occupational health and environmental regulations.

The local municipal authorities or specialized waste management companies can provide information concerning environmentally appropriate disposal.

11.0 Appendix

11.1 Technical data

	Symbol	Unit	w/o motor	BG75	1FK7034
Performance data					
Continuous force at zero speed	FC0	kN	5	4,013	5,000
Continuous force at max. speed	FC	kN	5	4,013	4,013
Peak force at zero speed	FP0	kN	5	5	5
Peak force at max. speed	FP	kN	5	5	5
Dynamic load capacity	C	kN	21	21	21
Holding force (motorbrake option)	FHold-MB	kN	N/A	5	5
Holding force (external brake option)	FHold-EB	kN	5	5	5
Max. linear speed	Vmax	mm/s		62	100
Max. acceleration	amax	m/s ²	6	6	6
Duty cycle	D	%	100	100	100
Mechanical data					
Screw type	–	–	Ball screw	Ball screw	Ball screw
Screw diameter	dscrew	mm	20	20	20
Screw lead	pscrew	mm	10	10	10
Lead accuracy			G7	G7	G7
Stroke (100 mm steps)	s	mm	100...700	100...700	100...700
Internal overstroke each side	s0	mm	1	1	1
Backlash	sbacklash	mm	0,07	0,07	0,07
Gear reduction	i		10	10	10
Efficiency	η	%	58	52	51
Electric data					
Motor type			N/A	Brushless DC	Servo
Nominal voltage	U	V DC	N/A	40	N/A
Nominal current	I	A	N/A	12,7	1,3
Peak current	Ipeak	A	N/A	10,8	1,9
Nominal power	P	kW	N/A	0,45	0,6
Environment					
Ambient temperature	Tambient	°C	0...+50	0...+50	0...+50
Max. humidity	□	%	95	95	95
Degree of protection	IP	–	20	20	20

For more information about the motors, please refer to the **High performance actuator catalogue** on ewellix.com, section CASM 32 – 63

11.2 Plans and Diagrams

Connecting and control scheme

NOTE

The device does not feature its own operating control elements. The operation takes place via a separate operating element (see separate operating manual).

The below diagram only shows a very basic control scheme.

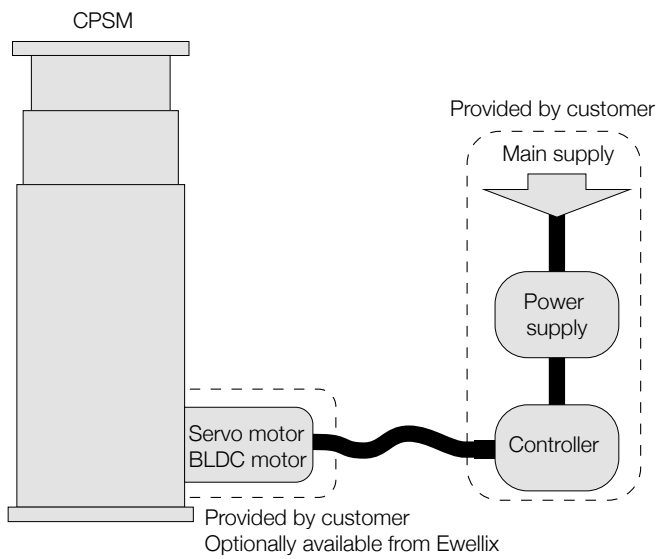

Output speed

Based on the standard ration of 1:10 the output speed in relation to the motor input speed is shown in the following diagram:

Pillar output speed [mm/s]

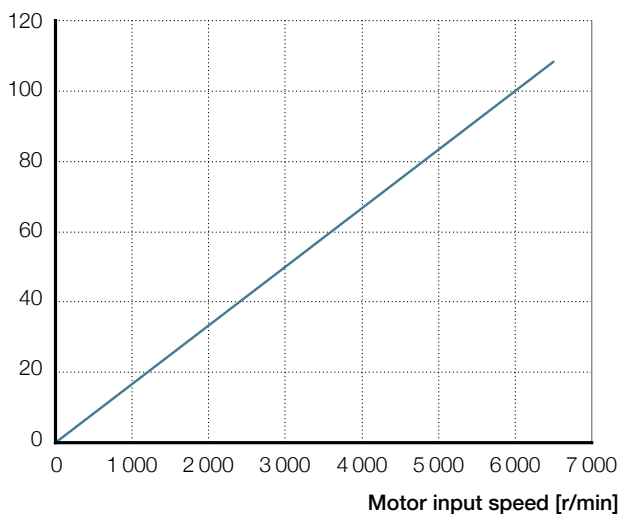

Specified offset load condition

The telescopic pillar CPSM is designed to be operated over the complete stroke length under blow mentioned load condition:

Bending load diagram 2 sections

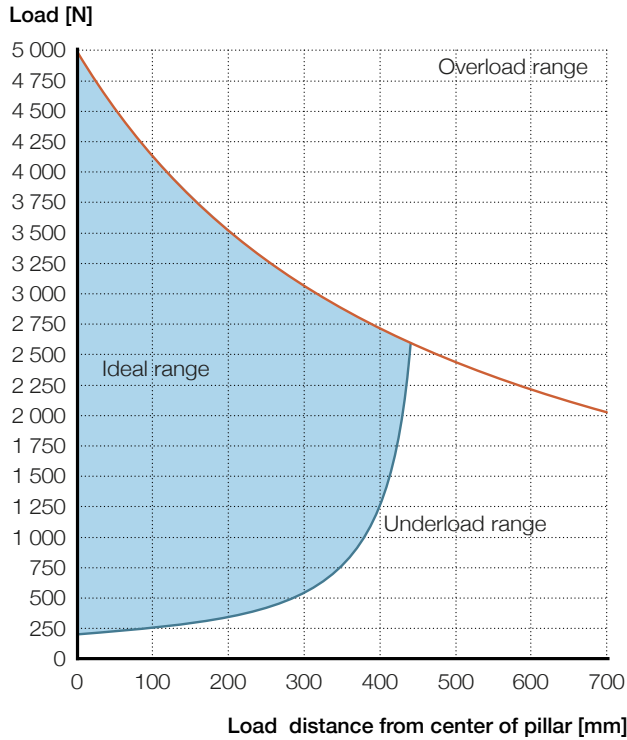

Bending loads diagram 3 sections*

Bending loads diagram 3 sections*

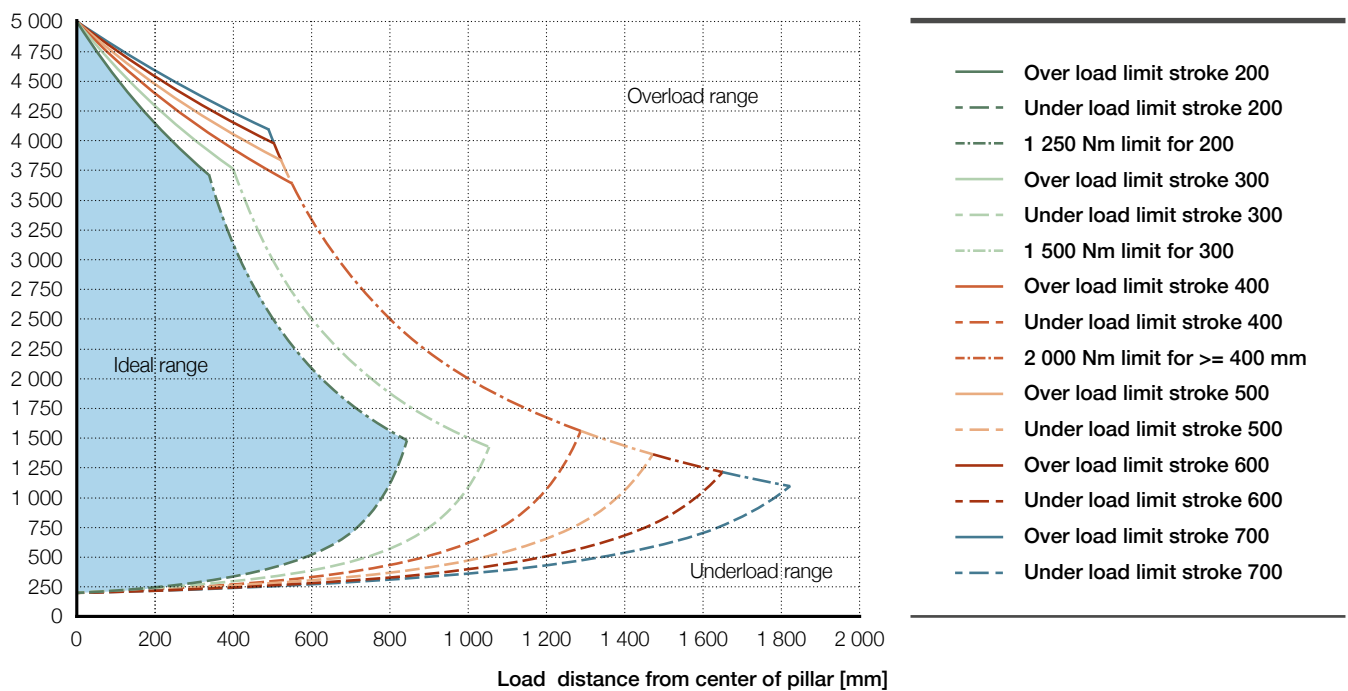

* in case of high speed and high duty cycle please contact Ewellix

Dimensional drawing

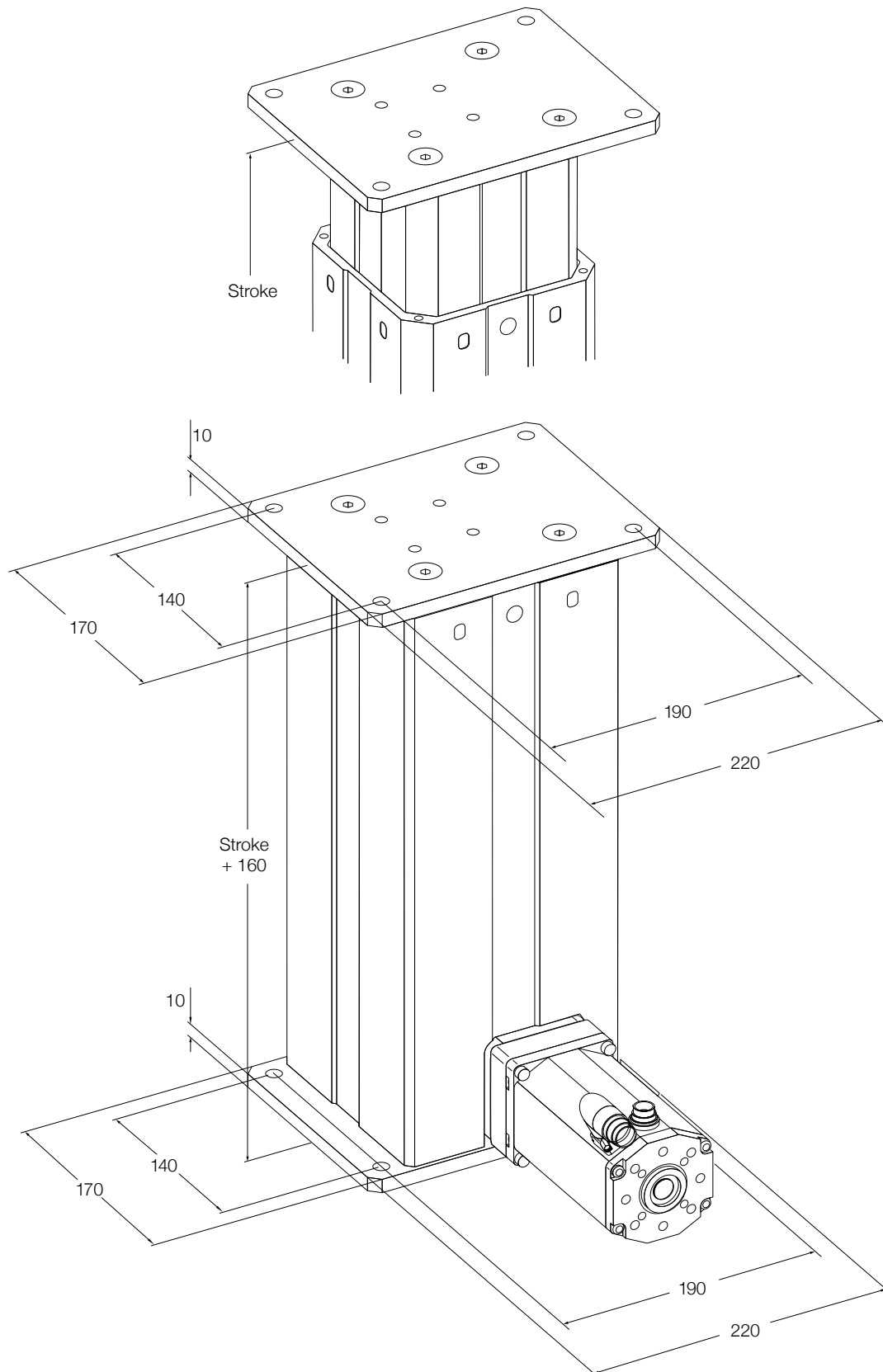

Ordering key

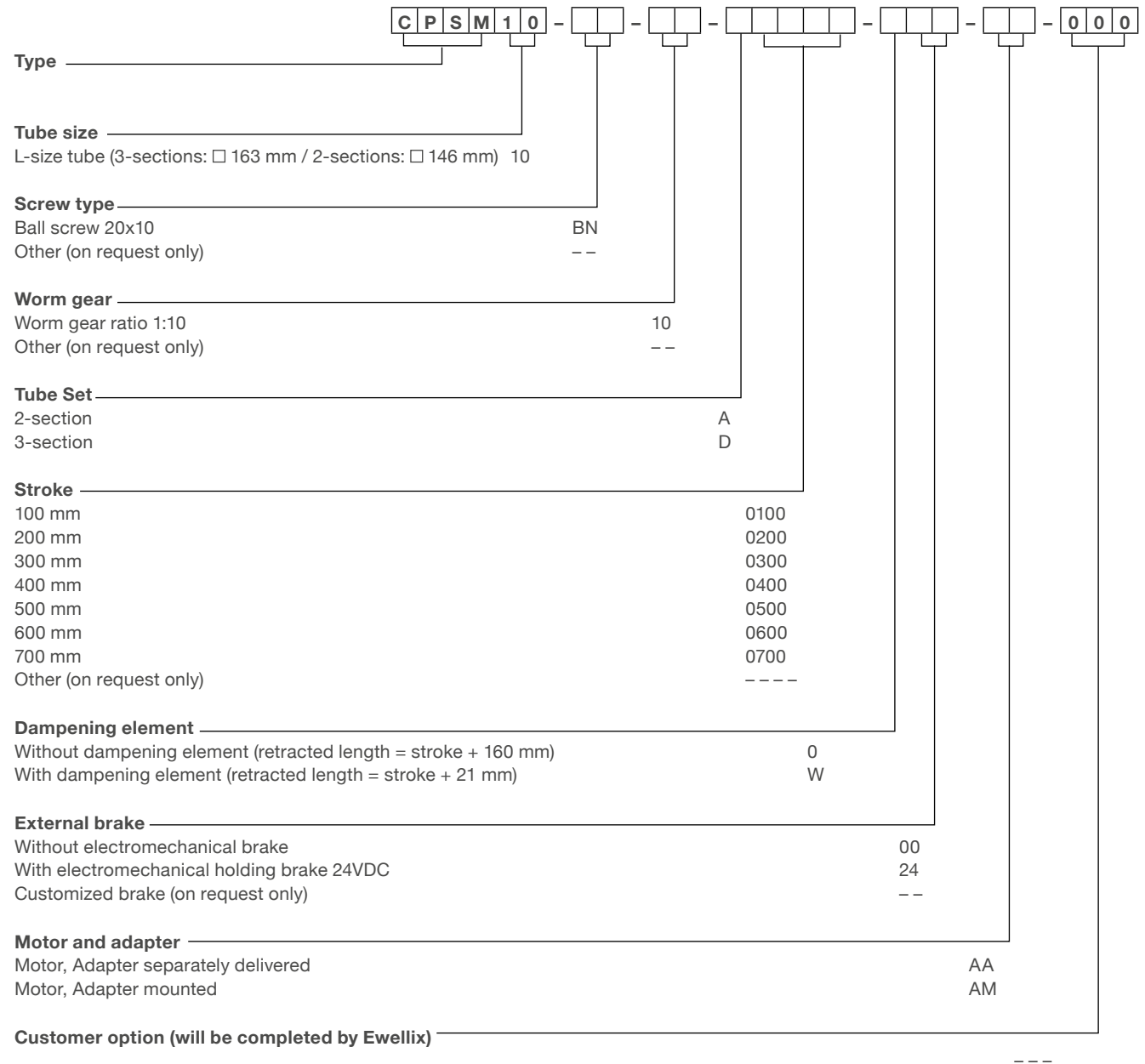





ewellix.com

© Ewellix

All contents of this publication are the property of Ewellix, and may not be reproduced or given to third parties (even extracts) without permission. Although great care has been taken in the production of this catalog, Ewellix does not take any responsibility for damage or other loss resulting from omissions or typographical errors. The photo may differ slightly in appearance from the actual product. Due to continuous improvements being made in our products, the product's appearance and specifications are subject to change without notice.

PUB NUM TC-08024-EN-May 2020