

EWELLIX

MAKERS IN MOTION

INSTALLATION, OPERATION AND MAINTENANCE MANUAL

THG/TLG/TLT

Telescopic pillars



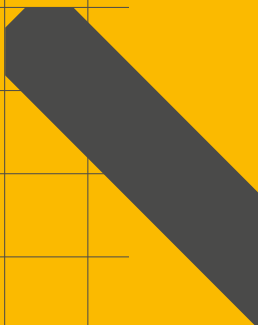
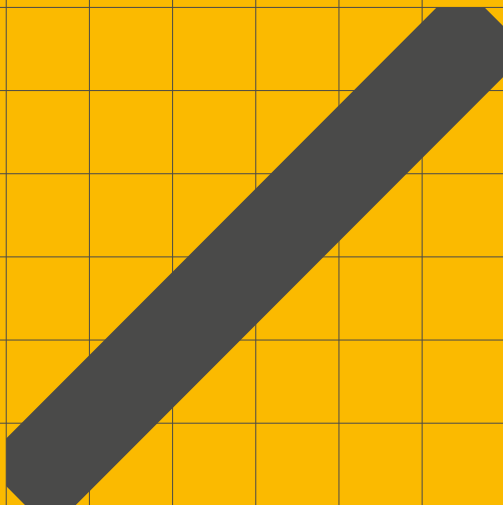

Contents

1.0	General information	4
1.1	Information on this manual	4
1.2	Explanation of symbols and signal words	4
1.3	Limitation of liability	5
1.4	Replacement parts	5
1.5	Warranty terms	5
1.6	Customer service	5
2.0	Safety	6
2.1	Intended use	6
2.1.1	Expected life time	6
2.1.2	Essential performance	6
2.2	Responsibility of the owner and processor	6
2.3	Personnel requirements	7
2.4	Specific dangers	7
2.5	Safety device	8
2.6	Safeguard against restart	8
2.7	Modifications of device	8
3.0	Technical data	9
3.1	Safety equipment	9
3.2	Operating conditions	9
3.3	Type label	9
4.0	Structure and function	10
4.1	Telemag THG, TLG	10
4.2	Telemag TLT	11
4.2.1	TLT1	11
4.2.2	TLT2	12
4.3	Brief description	13
4.4	Functional principle	13
4.5	Connections	13
4.6	Operating elements	14
4.7	Options	14
4.7.1	Impulse transmitter	14
4.7.2	Potentiometer	14
4.7.3	Cable feed	14
4.8	Accessories	14
4.9	Danger zones	15
4.9.1	Danger zone THG; TLG; TLT1	15
4.9.2	Danger zone TLT2	15
5.0	Transport, packaging and storage	16
5.1	Safety information for transport	16
5.2	Transport inspection	16
5.3	Return shipment to the manufacturer	16
5.4	Packaging	16
5.5	Symbols on the packaging	17
5.6	Storage	17
6.0	Installation and initial operational set-up	18
6.1	Safety	18
6.2	Installation position	18
6.3	Inspection prior to first operation	18
6.4	Installation	18
6.5	Connection to the control unit	21
6.5.1	Connect jack plug to control unit	22
6.5.2	Connect DIN-8 plug to control unit	23
7.0	Operation	24
7.1	Safety	24
7.2	Turn on and off	24
7.3	Precautions prior to use	24
7.4	Normal operation	24
7.5	Precaution after use	25
7.6	How to stop device in case of emergency	25
7.6.1	Shut down the telescopic pillar	25
7.6.2	Pull jack plug out of the KOM control unit	25
7.6.3	Pull the DIN-8 plug out of the BCU/VCU/SCU control unit	26
7.7	After use	26
8.0	Maintenance	27
8.1	Safety	27
8.2	Maintenance plan	28
8.3	Maintenance work	28
8.3.1	Cleaning	29
8.3.2	Visual inspection	29
8.4	Actions after maintenance has been completed	29
9.0	Malfunctions	30
9.1	Safety	30
9.2	Troubleshooting chart	31
9.3	Start of operation after fault has been eliminated	32
10.0	Dismantling and disposal	33
10.1	Safety	33
10.2	Dismantling	33
10.2.1	Dismantling the telescopic pillar	33
10.2.2	Pull the jack out of the KOM control unit	33
10.2.3	Pull the DIN-8 plug out of the BCU/VCU/SCU control unit	34
10.3	Disposal	34
11.0	Appendix	35

⚠ WARNING

Read this manual before installing, operating or maintaining this actuator. Failure to follow safety precautions and instructions could cause actuator failure and result in serious injury, death or property damage.

1.0 General information

1.1 Information on this manual

This manual provides information necessary for the proper and safe installation, operation, maintenance, dismantling and disposal of this pillar (also called device). It is an integral part of the equipment, and must be kept so that it is accessible to personnel.

Before doing anything with this device, personnel must read this manual thoroughly and understand its contents.

Compliance with all specified safety instructions and operating instructions is vital for safe and proper use of this device.

In addition, national and local governmental accident prevention regulations and general safety instructions must be observed in the area where this device is being used.

Illustrations in this manual are intended to facilitate a basic understanding of these concepts and may differ from the actual design.

1.2 Explanation of symbols and signal words

Safety precautions

Safety precautions in this manual are identified by symbols and signal words. These signal words (shown to the right) indicate the severity of the hazard.

Adhere to these safety precautions and act cautiously in order to avoid accidents resulting in personal injuries and damage to the device and the equipment into which it has been installed.

DANGER

Indicates a dangerous situation, which will lead to death or serious personal injury, if the precautionary measures are ignored.

WARNING

Indicates a dangerous situation, which can lead to minor or moderate injury or property damage, if the precautionary measures are ignored.

CAUTION

Indicates a dangerous situation, which can lead to minor or moderate injury if the precautionary measures are ignored.

NOTICE

Indicates information considered important, but not hazard-related (e.g. messages relating to property damage).



NOTE

Emphasizes useful hints and recommendations as well as information for efficient and trouble-free operation.

1.3 Limitation of liability

All information and notes in this manual were compiled under due consideration of valid standards and regulations, the present status of technology and our years of knowledge and experience.

The manufacturer will not be liable for damage resulting from:

- disregarding this manual
- unintended use
- employment of untrained personnel
- unauthorized retooling
- unauthorized technical changes to device
- use of unapproved spare parts

When ordering options for custom models or from the latest technical changes, the actual delivered product may differ from the explanations and illustrations in this manual.

The obligations agreed to in the contract for delivery, the general terms and conditions of Ewellix and the manufacturer as well as the legal regulations which were in effect at the time the contract was entered into shall apply.

We reserve the right to make technical modifications in order to improve usability.

1.4 Replacement parts

The telescopic pillar is not designed for repair work by the owner/operator. All warranty and service claims are void if repairs are not performed by the manufacturer or another entity approved by the manufacturer.

WARNING

Risk of injury through the use of incorrect replacement parts

Installation or use of incorrect replacement parts may result in safety risks for personnel and may also cause damage, malfunction or complete failure of the drive.

Therefore:

Defective original parts for the pillar must only be replaced by the manufacturer.

To have defective original parts replaced, the pillar must be uninstalled and sent to the manufacturer.

1.5 Warranty terms

The warranty terms are included in the manufacturer's Terms and Conditions contained in the Ewellix sales contract that governs this sale.

1.6 Customer service

Ewellix Customer Service is always available to provide technical information and answer questions.

The contact information for Ewellix Customer Service can be found on www.ewellix.com.

In addition, our employees are always interested in acquiring new information and experience gained from practical application; such information and experience may help improve our products.

2.0 Safety

This section provides an overview of all the main safety aspects of installing, operating, and maintaining this device.

Failure to comply with the guidelines and safety instructions contained in this manual may result in serious hazards that could cause possible serious injury or death or damage to the device or equipment.

2.1 Intended use

The telescopic pillars – THG, TLG, and TLT – have been designed and built exclusively for the intended purposes as described below.

- These pillars are to be only used for a dynamic centric and offcenter lift charged with pressure.
- These pillars have been especially designed for height adjustments of medical applications, computer work and assembly tables. Any other use of these pillars must be authorized by the manufacturer; see cover back for the address.
- These pillars are only suitable for indoor applications and may not be exposed to:
 - Environment with flammable anesthetic or other flammable substances.
 - Environment with enriched oxygen concentration
 - Environment with enriched radiation
 - Wet room environment

Any use that extends beyond the intended use or a use different than the one described above is deemed misuse.

⚠ WARNING

Risk from misuse

Any utilization of this device beyond its intended purpose or a different use of this device may potentially lead to hazardous situations.

Any type of claims resulting from damage caused by misuse are excluded.

2.1.1 Expected life time

The product is designed for a lifetime of 20 000 cycles at 300 mm load with centric load operated according to the specifications seen in the datasheets or 10 years.

2.1.2 Essential performance

Holding and moving of loads

2.2 Responsibility of the owner and processor

The device is designed for use in commercial applications by its owner or processor.

The processor is the contracting partner of the reseller or the manufacturer. The processor installs the device in a complete system (application).

The owner or processor of the system is therefore subject to the requirements of the Occupational Health and Safety Act.

In addition to the safety instructions in this manual, the owner or processor must do the following, concerning safety and accident prevention guidelines and environmental protection regulations, applicable to the site of the system's installation:

- Inform themselves of applicable industrial safety regulations. They must also determine additional hazards that arise due to the specific working conditions prevailing at the site where the device is installed, using risk assessment. The risk assessment must be implemented in the form of work instructions for device operation.
- Confirm that the work instructions created for the system, including the device, satisfy current legal requirements, and if not, alter the instructions accordingly.
- Clearly regulate and specify the responsibilities for installation, operation, maintenance, and cleaning.
- Ensure that all employees who deal with the device have read and understood this manual.
- Provide personnel with the required protective equipment.
- Provide training for personnel at regular intervals and inform personnel of the hazards.

In addition, the owner or processors must ensure that the device is in adequate working condition. They must do the following:

- Ensure that the maintenance intervals described in these instructions are complied with.
- Have all safety devices inspected regularly for function and completeness.

2.3 Personnel requirements

⚠ WARNING

Danger of injury if personnel are insufficiently qualified

If unqualified personnel install, operate, or maintain the device or are in the appliance's danger zone, hazards may arise which can cause serious injury and substantial damage to property.

This manual specifies the personnel qualifications required for the different areas of work, listed below:

Operator

The operator is part of the staff of the operating company and has been trained by the operating company. The operator is familiar with the regulations that apply at the operating site of the machine and has been informed about the hazards imposed by the entire system.

The operator also has been verifiably trained by the operating company and based on this training he/she is able to safely

- operate the equipment,
- eliminate specific disruptions,
- carry out specific maintenance work.

Qualified electrician

Based on his technical training, knowledge, experience and knowledge of the applicable standards and regulations, the Qualified electrician is able to perform work on electrical systems and recognise and avoid potential hazards himself.

The qualified electrician is specially trained for the area of responsibility he is involved with and knows the relevant standards and regulations.

The qualified electrician must comply with the requirements of the applicable legal regulations for accident prevention.

Qualified personnel

Qualified personnel is able to carry out assigned work and to recognize and prevent possible dangers self-reliantly due to its professional training, knowledge and experience as well as profound knowledge of applicable regulations.

User

The user uses and operates the pillar for its intended purpose without other prior knowledge.

The workforce must only consist of persons who can be expected to carry out their work reliably. Persons with impaired reactions due to, for example, the consumption of drugs, alcohol, or medication are prohibited.

2.4 Specific dangers

The following section specifies residual risks which may result from using the pillar and have been established by means of a risk assessment.

⚠ WARNING

Safety considerations

- If operated with a non Ewellix control unit the secondary circuit of the controller must secure a double isolation (2 MOPP) from main supply including a PE (earth ground)
- If external fuses are needed in medical applications they must correspond to IEC60127 with a current switch off capability of 1 500 A
- The risk of a delay between stopping signal and physical stop of the product must be considered before usage
- The product does not contain means to release person.
- The product is intended to operated only in "touch mode". In case of any defect the pillar has no further lifting function. If this can cause a risk in the application, additional means must be considered.

Electric current

⚠ WARNING

Danger to life caused by electric current!

Touching conductive parts causes a direct danger to life. In addition, damage to insulations or individual components can cause danger to life.

Therefore:

- In the event of damage to insulation, switch off the power supply immediately and have the defective parts repaired.
- Work on the electric system must be carried out only by skilled electricians.
- De-energize the machine for all work on the electrical system.
- Before maintenance, cleaning or repair work, switch off the power supply and secure it against being switched on again while it is being worked on.
- Do not bridge fuses, or make them ineffective. When changing fuses, make sure you use the correct amperage. Keep moisture away from conductive parts. This can cause short circuit.

Moving parts

⚠ WARNING

Risk of injury from moving parts

Moving parts may cause serious injuries.

Therefore:

Do not reach into moving parts or touch moving parts during operation.

2.5 Safety device

⚠ WARNING

Emergency stop switch

The pillars THG, TLG, TLT have not any on/off- switch. In case of failures, risks the pillar must be disconnected from the control unit, respectively the control unit from main supply. That for an emergency stop switch must be provided in the application.

Integration with an emergency-stop required (for certain applications)

The pillar is intended for use within a complete system (lifting column plus control). It does not have its own operating control elements and does not have an independent emergency-stop function.

Install emergency stop functions for the pillar and integrate them into the safety chain of the complete system prior to operating the pillar.

The emergency stop function has to be connected in such a way that a disruption of the power supply or the activation of the power supply after a power disruption cannot cause a hazardous situation for persons and objects.

The emergency shut-off systems must always be freely accessible.

Furthermore, within the complete system, install a function to set free a patient, if the system has just blocked.



NOTE

The manufacturer of the equipment specifies the applications in which the emergency stop systems must be installed.

The following safety devices are already installed: THG/TLG/TLT

The brake takes care of self-preservation in idle mode. The maximum self-preservation force of the brake in idle mode is the compressive or tensile force of the telescopic pillar (refer to technical data sheets in the appendix).

The THG 11, TLG 11 and TLT 11 telescopic pillars have an integrated over-current safety shut-off.

In its standard version, the device does not feature an over-current safety shut-off and must be shut off via an Ewellix control unit.

A screw nut converts the rotation of the gear unit into a linear motion. If the ball screw nut breaks, its function is taken over by the integrated back-up nut and the telescopic pillar can engage in a one-time movement against the load direction.

⚠ DANGER

In case of use a third-party control unit see chapter 6.5 **Connection to the control unit.**

The following safety devices are incorporated into the separate control unit:

The standard version of the pillar does not feature any thermal fuse protection and can overheat and be damaged. In case of overheating, an Ewellix control unit with an integrated thermal switch will turn the device off.

NOTICE

Authorized only accessories (operating elements) with buttons (monostable).

NOTICE

Damage from overheating

Overheating of the telescopic pillar can cause damage. Using a control unit that is not recommended by Ewellix can result in overheating of the telescopic pillar.

2.6 Safeguard against restart

To secure the telescopic pillar against unintentional restart:

1. Pull the power line plug of the control (connected to the telescopic pillar) out of the power outlet.

⚠ WARNING

Life-threatening situation through unauthorized restart!

For work in hazard zones, there is a risk that the power supply will be turned on without prior authorization. This presents a life-threatening situation for people in the hazard zone. Therefore:

- Follow the information concerning safeguarding against restarting of the power supply in the chapters of this operating manual.
- Always follow the process to safeguard against a restart as described below.

2.7 Modifications of device

⚠ WARNING

To prevent hazardous situations and to ensure optimal output, changes, additions and retooling of the pillar must not be carried out unless explicitly authorized by Ewellix.

3.0 Technical data

NOTE

Technical data (dimensions, weights, output, connection values etc.) can be found in the appendix.

3.1 Safety equipment

WARNING

Life-threatening situation due to malfunctioning safety equipment!

Safe operation is possible only if safety equipment is in good working order.

Therefore:

- Always check functionality of safety equipment according to the maintenance plan in section 8.2 of this manual.
- Never disengage safety equipment.
- Safety equipment may never be bypassed or modified.

3.2 Operating conditions

Environment

Indoor use only

Information	Value	Unit
Ambient temperature	+10 to +40	°C
Relative atmospheric humidity, maximum (no build up of condensation)	up to 85	%
Air pressure	700 to 1 060	hPa
Maximum altitude above sea level	2 000 (3 000 for MOPP)	m
Supply mains with overvoltage	category I	-
Pollution degree	2	-

Duration (intermittent)

Information	Value	Unit
Maximum operating time without a break	1	Minutes
Break until next operation	9	Minutes

3.3 Type label

The type label contains the following information:

Fig. 1

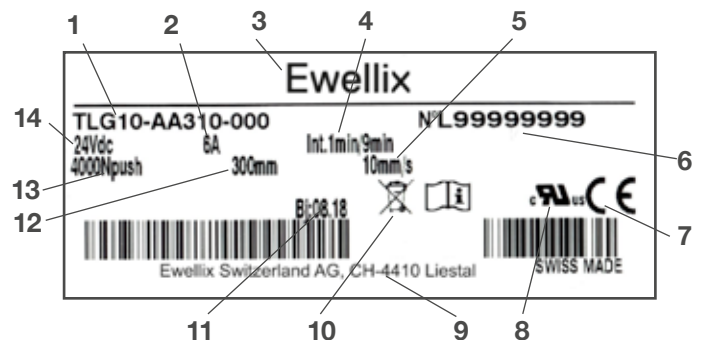

Type label (without options)

1. Type designation
2. Current consumption
3. Manufacturer
4. On/Off-Time (duty cycle)
5. Speed of the telescopic pillar
6. Serial number
7. CE mark
8. UL quality mark
9. Manufacturer's address
10. Disposal information
11. Manufacturing date (month.year)
12. Maximum lift length
13. Compressive force
14. Voltage

For further information see into the manual

4.0 Structure and function

4.1 Telemag THG, TLG

Fig. 2

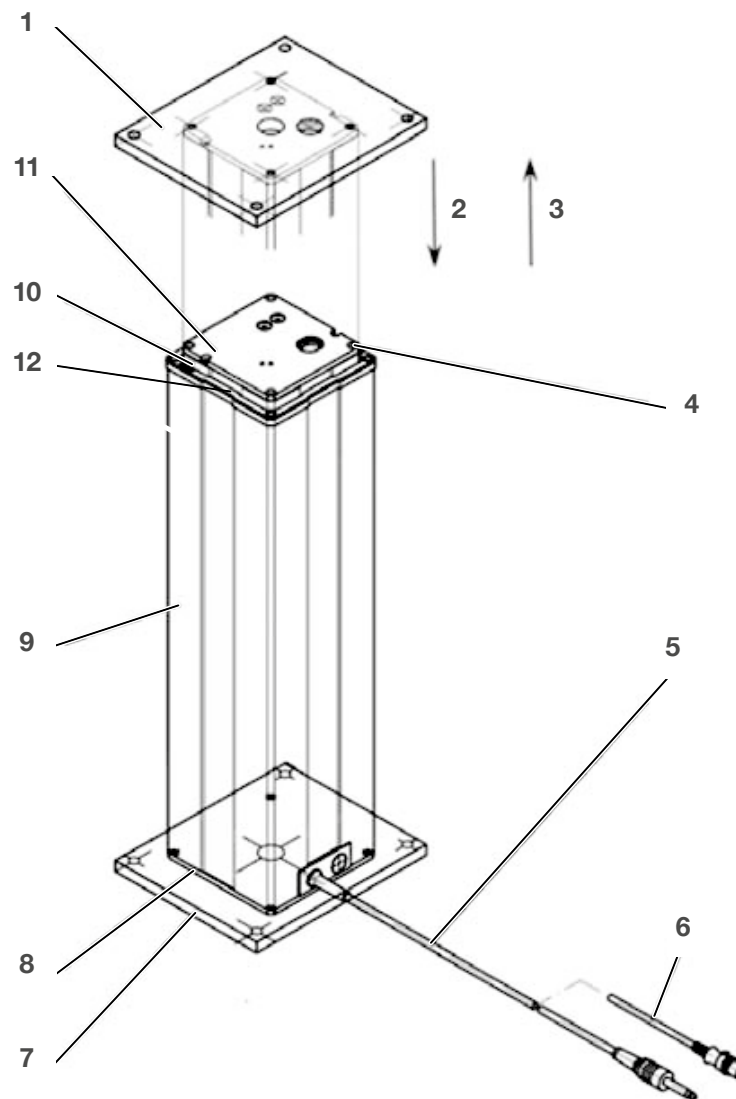

- | | |
|---|--------------------------------------|
| 1. Upper attachment plate (optional) | 7. Lower attachment plate (optional) |
| 2. Direction of motion when retracting | 8. Lower base plate |
| 3. Direction of motion when extending | 9. Outer guide tube |
| 4. Transport screws | 10. Inner guide tube |
| 5. Jack plug connection cable | 11. Upper base plate |
| 6. DIN-8 plug connection cable (optional) | 12. Middle guide tube |

4.2 Telemag TLT

4.2.1 TLT1

Fig. 3

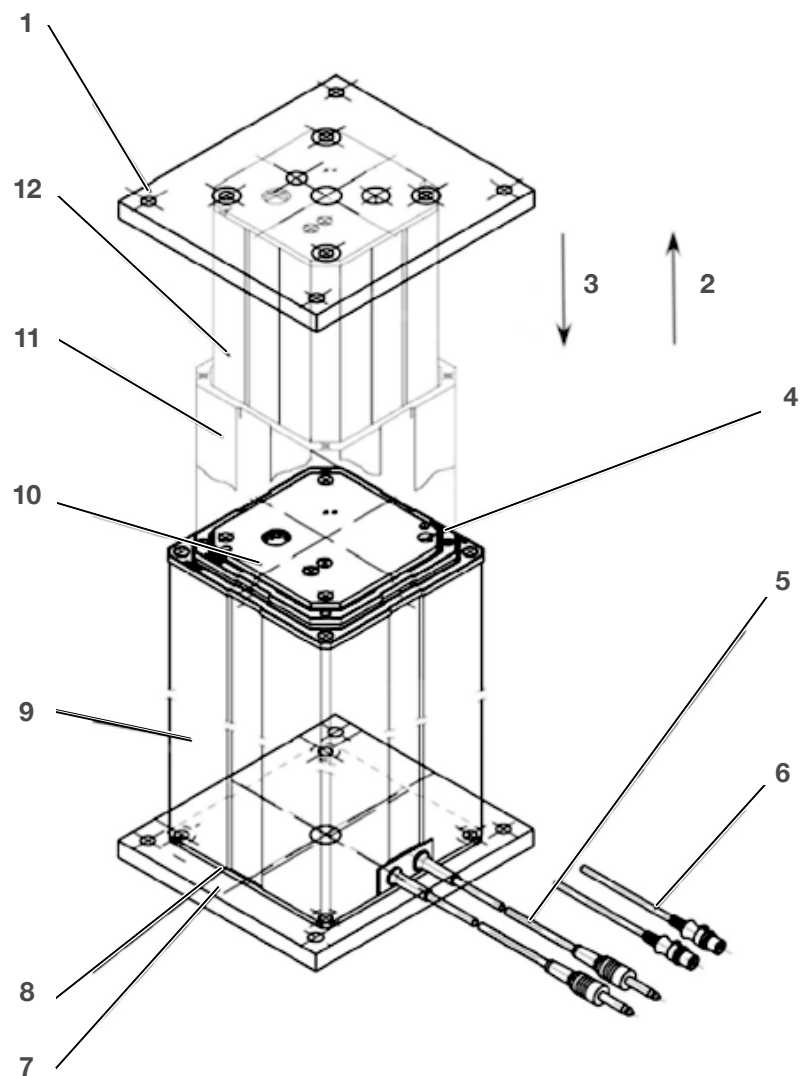

- | | |
|---|--------------------------------------|
| 1. Upper attachment plate (optional) | 7. Lower attachment plate (optional) |
| 2. Direction of motion when extending | 8. Lower base plate |
| 3. Direction of motion when retracting | 9. Outer guide tube |
| 4. Transport screws | 10. Upper base plate |
| 5. Jack plug connection cable | 11. Middle guide tube |
| 6. DIN-8 plug connection cable (optional) | 12. Inner guide tube |

4.2.2 TLT2

Fig. 4

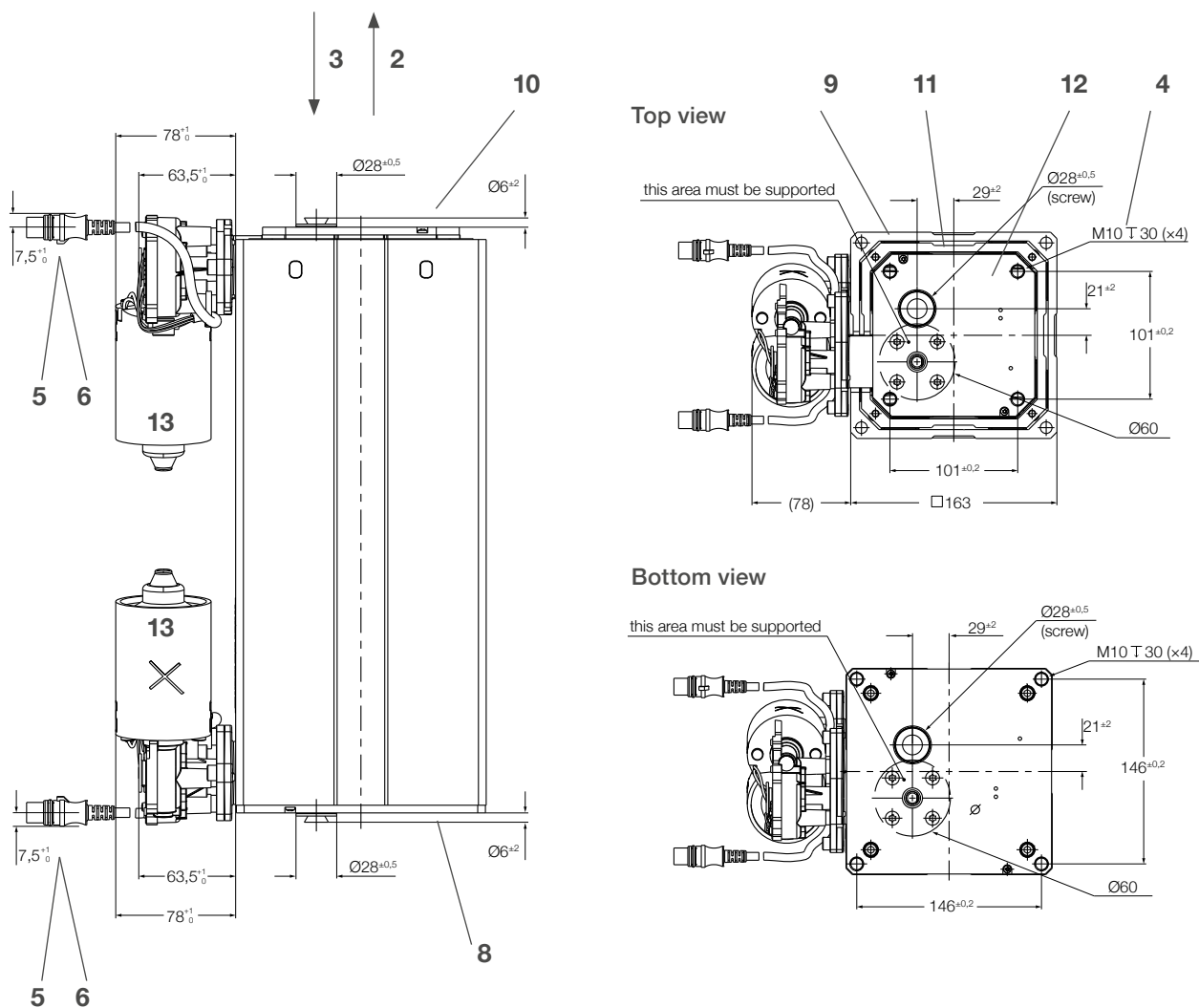

- 1. Upper attachment plate (optional), see fig.3
- 2. Direction of motion when extending
- 3. Direction of motion when retracting
- 4. Transport screws (refer → chapter 6.4 Installation)
- 5. Connection cable DIN8
- 6. Connection cable mini fit (optional)
- 7. Lower attachment plate (optional), see fig.3

- 8. Lower base plate
- 9. Outer guide tube
- 10. Upper base plate
- 11. Middle guide tube
- 12. Inner guide tube (not visible)
- 13. Motors and Encoders (optional)

4.3 Brief description

The Telemag is an electric telescopic pillar with guiding tubes.

The pillar is used in a complete system and is used exclusively for dynamic centric compression- or eccentric compression-loaded lifting movements.

The telescopic pillar consists of two or three nested guide tubes which are extended and retracted by an integrated drive.

The guide slide bearings ensure extension and retraction even with off-centered loads.

Direct current motor with a worm gear drives a threaded spindle. A threaded nut, which is permanently connected to the actuator, runs up and down on the spindle and generates the feed motion. The slide tube is connected on the front side via the base plate to the guide tubes.

Extension or retraction of the telescopic tube occurs by changing the rotational direction of the motor. The thrust speed is dependant on the load.

4.4 Functional principle

Fig. 5

System with control unit

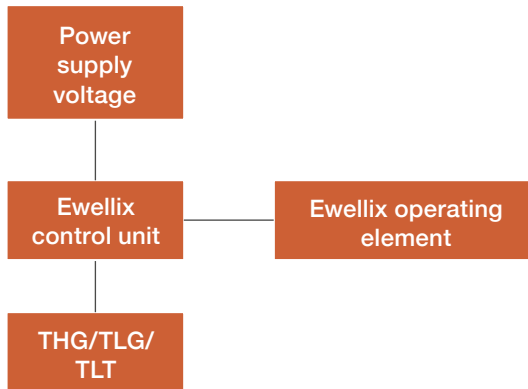

The Telemag telescopic pillar requires an external control to power the motor unit. It is connected to the THG/TLG via a connecting cable and to the TLT via two connecting cables.

THG/TLG

The main difference between the THG/TLG and TLT telescopic pillars is of the different sizes of the guide tube and the number of spindles (refer to chapter 3 Technical data).

The magnitude of the load speed and transverse force determines the choice of drive motors and their power. This ultimately results in the deviations in the values for compres-

sive forces and thrust speed as well as additional functions such as cable feedthroughs.

TLT1

Compared to the Telemag THG and TLG telescopic pillars, two spindle systems in the TLT telescopic pillar produce double the thrust speed. There are two connection cables for two DC motors permanently installed on the TLT telescopic pillar.



NOTE

Additional differences between the THG, TLG and TLT telescopic pillars are found in the sections on connections and data sheets in the **Appendix**.

TLT2

Compared to TLT1, the TLT2 has placed the 2 DC Motors and Electronic connection outside of the tube to support a reduced Built in Dimension.

4.5 Connections

Fig. 6

THG/TLG connections

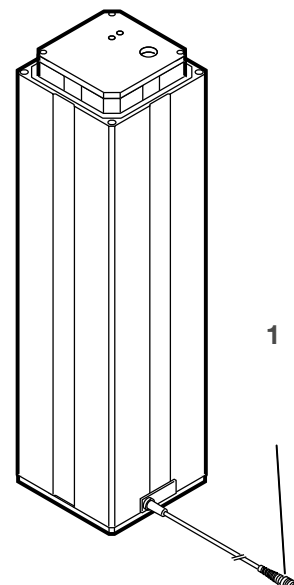

THG/TLG One low voltage plug (1) connect the device to the power supply via an external Ewellix control.

- 1. Connections to an external control (jack or DIN-8 plug). In case of use a third-party control unit see chapter 6.5

Connection to the control unit.

Fig. 7

TLT connections

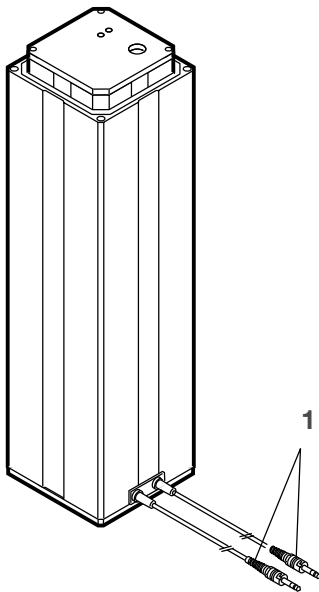

TLT Two low voltage plugs (1) connect the device to the power supply via an external Ewellix control unit.

1. Two connections 1 to an external control (jack or DIN-8 plug). In case of use a third-party control unit see chapter 6.5 Connection to the control unit.

4.6 Operating elements

NOTE

The pillar does not feature its own operating elements. The operation takes place via a Ewellix operating element on an external Ewellix control unit (→ **Separate operating instructions**).

4.7 Options

The options listed below are available for the entire THG, TLG and TLT telescopic pillar model series if not indicated otherwise.

4.7.1 Impulse transmitter

THG/TLG/TLT

The impulse transmitter picks up impulses from a ring magnet via the Hall sensor. The ring magnet is attached to the motor gear. The control calculates the position or lift of the extended drive from the number of impulses.

This results in the possibility of the telescopic pillar’s drive extending or retracting to one or more defined positions.

4.7.2 Potentiometer

THG/TLG

Alternatively, the drive can be extended or retracted to one or more defined positions via a potentiometer. This option is only possible for the THG telescopic pillar with the triple guide tube set. There are no limitations for the TLG telescopic pillar so the potentiometer is available in the double or tripe guide set.

4.7.3 Cable feed

THG/TLG/TLT

With all models, you have the option to feed the power supply voltage through the telescopic pillar via a cable feed.

Therefore, there are customer side to install separately fuses in the final application. They must correspond to IEC 60127 with current switch off capability of 1500 A.

In case of connection the cable feed with earth ground, be sure and control this electric function regular.

NOTE

For the THG telescopic pillar with potentiometer, the triple guide tube set must be used (refer to chapter → **4.7.2 Potentiometer**).

4.8 Accessories

Accessories	Model series	Note
Ewellix control	THG, TLG, TLT	See the separate operating manual
Ewellix operating element	THG, TLG, TLT	See the separate operating manual
Attachment plates	THG, TLG, TLT	Use for complete transfer of force in the application to the Telemag telescopic pillar
Annually	THG, TLG, TLT	Use for attaching the attachment plates on the base plates of the Telemag telescopic pillar

4.9 Danger zones

4.9.1 Danger zone THG; TLG; TLT1

The following areas are dangerous:

- between the tube ends (2) and mounting plate (1) in the completely retracted position.
- entire lift area between (1) and (3)

Fig. 8

Danger zones

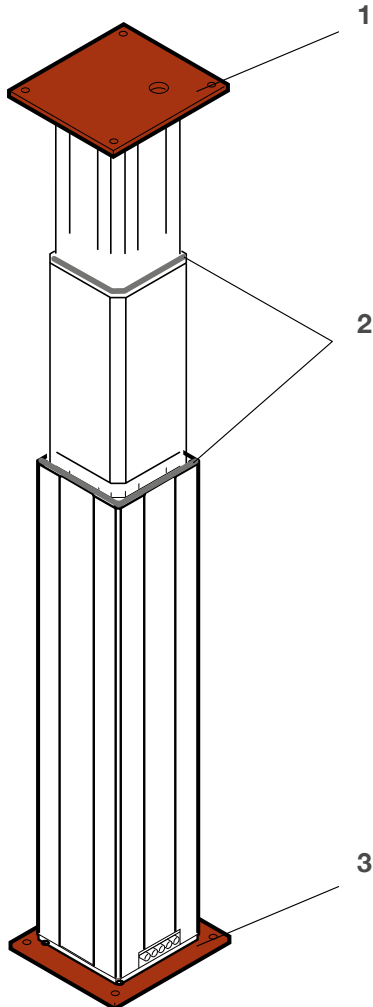

4.9.2 Danger zone TLT2

The following areas are dangerous:

- between the tube ends (2) and mounting plate (1) in the completely retracted position.
- entire lift area between (1) and (3)
- squeezing fingers and sharp edges (1) and (2)
- electronic equipment (motor, printed circuit board and wiring) (2) and (3)
- rotating elements (2) and (3).

Fig. 9

Danger zones

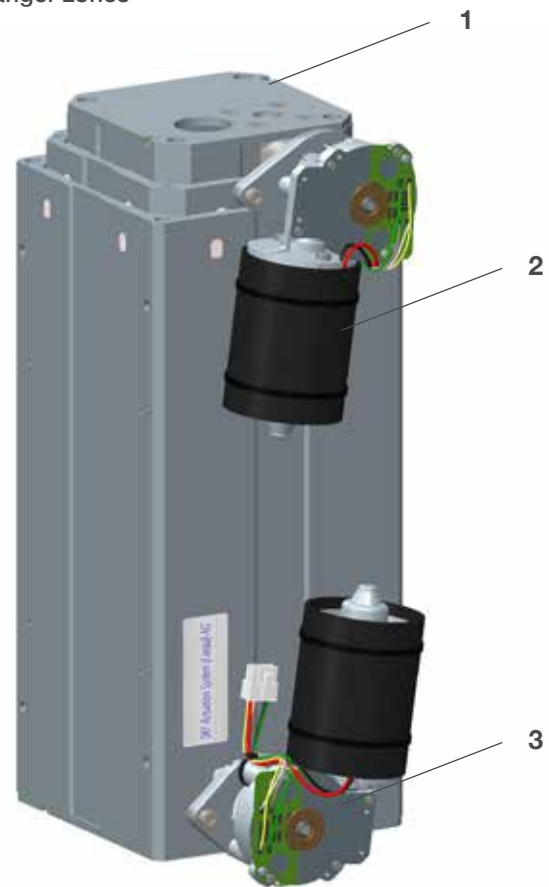

⚠ WARNING

- For TLT2 a prevention from Squeeze fingers and accessible rotating and electrical parts must be secured prior to use and operation.
- Cleaning is not allowed for electronic Equipment
- The TLT2 is not allowed to run into its mechanical end of travel limits during normal operation.
- The TLT2 must only be operated with a suitable current limit board.

5.0 Transport, packaging and storage

5.1 Safety information for transport

Improper transport

⚠ CAUTION

Material damage due to improper transport

Improper transport may cause transported items to fall down or topple over. This may cause costly material damage. Therefore:

- Proceed carefully during the unloading of the packaged items during delivery as well as during the transport to its final destination. And comply with the symbols and information shown on the packaging.
- Only remove device from packaging right before installation. Note terms and conditions for storage for any return transport to the manufacturer (refer to chapter [↪ 5.6 Storage](#)).

5.2 Transport inspection

The pillar is delivered as one unit in a box or packed on pallets.

Immediately upon receipt, the shipment is to be checked for completeness and transport damage.

Check scope of delivering

The scope of delivery of the pillar consists of the following:

- The complete telescopic pillar of the Telemag series (THG, TLG, or TLT).
- Attached cable and low-voltage plug (depending on the version with jack or DIN-8 plug).
- Accessories (optional).

Check shipment for transport damage

1. Unpack upon receipt.
2. Check connection socket for damage.
3. Check the telescopic pillar for damage, dents and scratches.

In case of visible exterior transport damage, proceed as follows:

1. Do not accept delivery or only with reservations.
2. Record scope of damage on the transport documents or on the bill of delivery of the shipping company.
3. Initiate claim.



NOTE

Report any damage as soon as it has been recognized. Damage claims may only be exercised within the carriers' claims periods.

5.3 Return shipment to the manufacturer

Proceed as follows for any return shipment:

1. Uninstall the pillar if necessary (refer to chapter [↪ 10 Dismantling and disposal](#)).
2. Pack the pillar in its original packaging. Follow storage conditions (refer to chapter [↪ 5.6 Storage](#)).
3. Send pillar to manufacturer.

5.4 Packaging

For packaging

The individual packaged pieces have been packaged appropriately for the expected transport conditions. Only environmentally-friendly materials were used for the packaging.

The packaging is supposed to protect the individual components from transport damage, corrosion and other damage prior to installation. Therefore, do not destroy the packaging and only remove the device shortly prior to installation. Keep package for potential return shipment to the manufacturer (refer to chapter [↪ 5.3 Return shipment to the manufacturer](#)).

When you dispose of packaging material, do so in accordance with the relevant legal requirements and local regulations.

Handling of packaging materials

⚠ CAUTION

Incorrect disposal can damage environment

Packaging materials are valuable raw materials and in many cases can continue to be used or can be properly processed and recycled. Incorrect disposal of packaging materials may pose risks to the environment.





Therefore:

Dispose of packaging materials in accordance with the environmental regulations.

5.5 Symbols on the packaging

The following symbols have been placed on the packaging.

Always adhere to the message in the symbols during transport. Do not store outside.

Symbol	Explanation
Top 	The arrow tips on the sign mark the top of the package. They must always point upwards; otherwise the content could be damaged
Fragile 	Marks packages with fragile or sensitive contents. Handle the package with care; do not allow to fall and do not expose to impacts
Protect against moisture 	Protect packages against moisture and keep dry.
Component sensitive to electrostatic charge 	The packing contains components which are sensitive to an electrostatic charge. Only allow packaging to be opened by trained personnel. Establish potential equalisation before opening.

5.6 Storage

Store packaging pursuant to the following conditions:

- Do not store outside.
- Store in dry and dust free place.
- Protect from sunlight.
- Avoid mechanical vibrations.
- Storage temperature: -20 to +40 °C.
- Relative humidity: max. 85 % (prevents build up of condensation).

- For storage longer than 3 months, check the general condition of all parts in the packaging on a regular basis. If necessary, refresh or renew the conservation.



NOTE

Comply with additional requirements set forth on the packaging concerning storage.

6.0 Installation and initial operational set-up

6.1 Safety

Electrical equipment

WARNING

Life-threatening danger due to electric shock or electrocution and crush hazard!

There is a life-threatening hazard when touching live components. Also, live electrical components can move unexpectedly and can cause serious injuries.

Therefore:

- Prior to starting work, switch off the power supply and safeguard it from being re-started. The TLT2 must only be operated with a suitable current limit board.

Safeguarding against restart

WARNING

Life-threatening danger if restarted without authorization!

When correcting faults, there is danger of the energy supply being switched on without authorization. This poses a life-threatening hazard for persons in the danger zone.

Therefore:

- Prior to starting work, switch off the power supply and safeguard it from being switched on again.

6.2 Installation position

- Take note of the operating conditions (↳ [Section 3.2](#)).
- The device must not be exposed to strong UV radiation nor to corrosive or explosive media in the air nor to other aggressive media.

6.3 Inspection prior to first operation

- To be performed by qualified personnel.

Prior to the first operation, the following tests and readings have to be performed and documented:

- Check visual the labeling and all designations from cables and components
- Check visual condition (refer to chapter ↳ [8.3.2 Visual check of condition](#)).
- Function check of operating features and safety features.

NOTE

Additional information concerning inspections and readings (refer to chapter ↳ [8 Maintenance](#)).

6.4 Installation

- To be performed by qualified personnel.

WARNING

Risk of injury and property damage due to manipulation of the screws on the device

Manipulation or loosening the screws on the pillar or on the options can cause injuries and damage during operation.

Therefore:

- Never loosen screws on the device (except transport screws, see next page).

The telescopic pillar is attached to the Ewellix attachment plates (accessories) or to plates supplied by the customer on the application.

NOTE

When using your own attachment plates, install them according to the technical data sheets (↳ [Appendix](#)).

Fig. 10

Alignment of the pillar (mounting position 180 °C turned permitted)

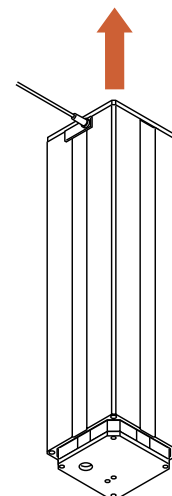

NOTICE**Damage due to penetrating liquids**

Liquids which get on the guide tube can damage the pillar.
Therefore:

- Locate the appliance so that the device will not be exposed to liquids.
- Align the pillar during installation (↳ **fig. 9**) so that liquid which gets in the guide tube cannot get into the inner guide tube.

1. Loosen and remove the four transport screws at the top (1).

Fig. 11



2. Loosen and remove 2 the four transport screws at the bottom (2).

Fig. 12

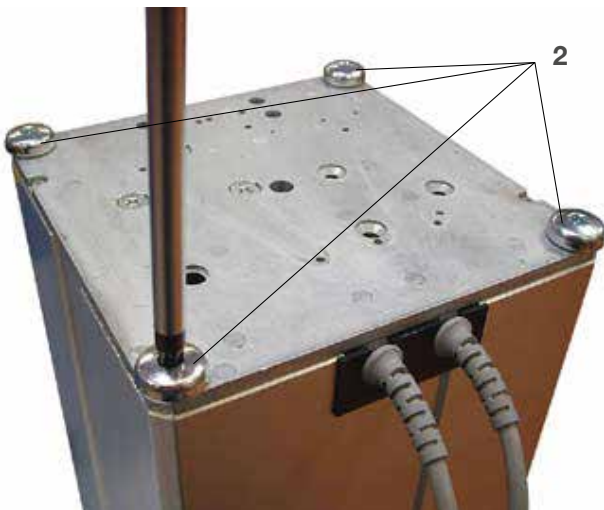
**NOTICE****Malfunctions due to scratching!**

Scratching the side surfaces of the tubes can lead to malfunctions during operation.

Therefore:

- During installation, ensure that the tube side surfaces are not scratched.

WARNING**Risk of injury and property damage due to insufficient fastening!**

Inadequate attachment can cause the base plates (3) and (6) to break and lead to serious injuries or damage.

Therefore:

- Use only the specified screws for mounting.
- When using attachment plates supplied by the customer, ensure that the base plates are always supported completely and the force is borne by the entire surface.
- Ensure that the steel or aluminum attachment plates supplied by the customer are at least 10 mm thick.

3. Attach the lower attachment plate (4) with four screws (5) on the outer guide tube or the lower base plate (6) using the specifications below.

Use the following screws for mounting:

Type	THG	TLG/TLT
Screws (1), (5)	M6 (4 pc.x 2)	M10 (4 pc.x 2)
Minimum screw-in depth	22 mm	25 mm
Strength category	10,9	10,9
Tightening torque	9 Nm	40 Nm

Fig. 13

Attaching the telescopic pillar

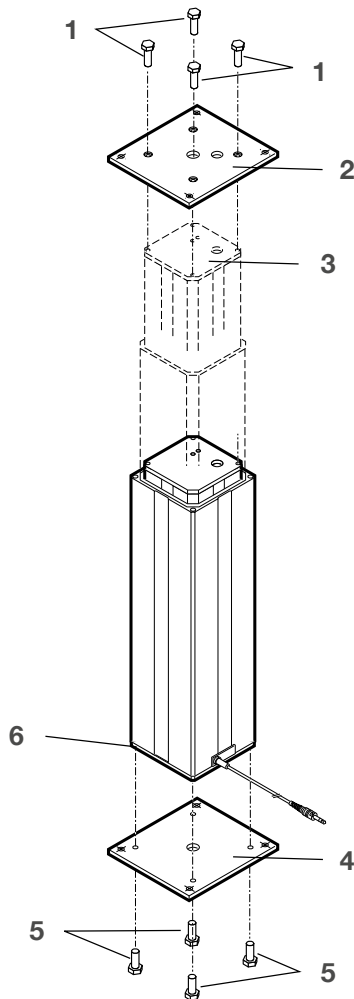

4. Ensure that the minimum screw-in depth and screw tightening torques are complied with (see above table).
5. Attach the upper attachment plate (2) with four screws (1) on the inner guide tube.
6. Ensure that the minimum screw-in and screw tightening torques are complied with (see above table).
7. Connect attachment plate (4) and (2) and elements of the application with attachment screws.

WARNING

Risk of injury and material damage due to excessive load!

Overloading the pillar can destroy the device which can lead to serious injuries or property damage.

Therefore:

- With excentric loads, take note of the load diagram (↳ **technical data sheets in the appendix**) or contact the manufacturer.

WARNING

Risk of injury from moving parts!

While driving onto solid objects, the force of the device may cause injuries. In the retracted end position, there is a risk of crushing between parts of the pillar.

Therefore:

- When retracting, ensure that no objects or body parts can be caught between the attachment plate (1) of the inner tube and the outer tube (2).
- When retracting, ensure that no objects or body parts can be caught between the attachment plates (1) and (3).
- If there is a risk of injury, depending on the installation location, a mechanical safety device must be installed.

8. Ensure that the telescopic pillar is not hindered in its movement anywhere in the lift area. Consider collision tests of the application.
9. When retracting, ensure that no objects or body parts can be caught between the attachment plate (1) of the inner tube and the outer tube (2) (↳ fig. 13).
10. Ensure that the motor cable cannot be crushed, pinched or pulled.
11. Ensure that the operating cable cannot be crushed, pinched or pulled. There is no location defined for mounting support the operating element. Ensure that the buttons on operating element cannot pressed without intention.
12. Connect the telescopic pillar to the control (refer to chapter ↳ **6.3 Inspection prior to first operation**).
13. Connect the operating element to the control (refer to ↳ **Separate operating manual**).

Fig. 14

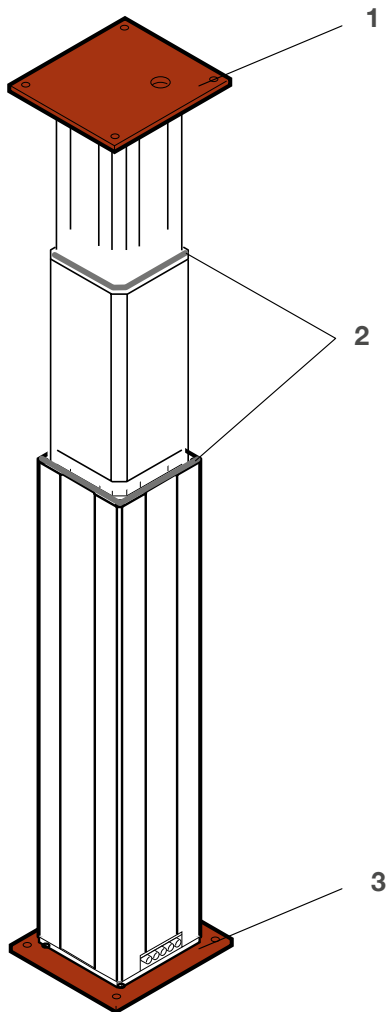

Fig. 15

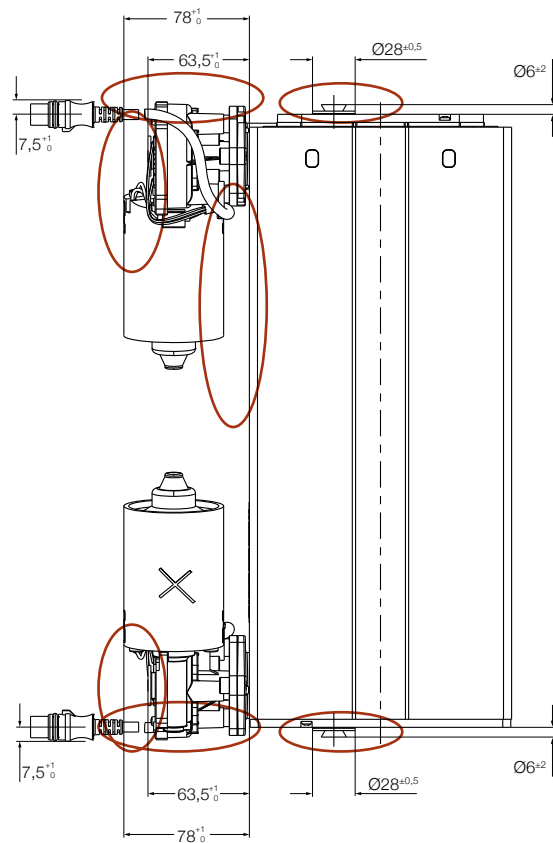
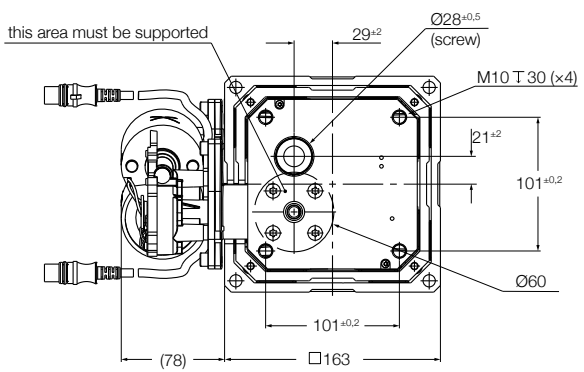

Fig. 16



⚠ WARNING

Risk of injury from use of a control unit not approved by the manufacturer!

The use of a third party control unit may lead to serious injuries or material damage. The manufacturer disclaims any liability for damage or injury that may be caused in conjunction with the use of a third-party operating element.

Therefore:

- Only use the Ewellix control unit.

⚠ WARNING

- Secure that Interfaces to the Pillar TLT2 are designed to prevent that there is a collision to the moving parts or the motor.
- Secure that Risk of Squeezing fingers is avoided
- Secure that no electrical parts which can cause injury can come in contact with human or equipment.

14. Connect the control to the power supply (↳ **Separate operating manual for the control**).
15. Ensure that the power plug of the control is accessible at all times.

- 16. Ensure that none of the supply or control cables can be pinched by motions of the application or by the telescopic pillar during the extension or retraction.
- 17. Ensure that the installation requirements for options have been met.
- 18. Extend the pillar (↳ fig. 14).
- 19. Check all guidance surfaces (1) and (2) of the profile tube for damage, dents and scratches.

Fig. 17

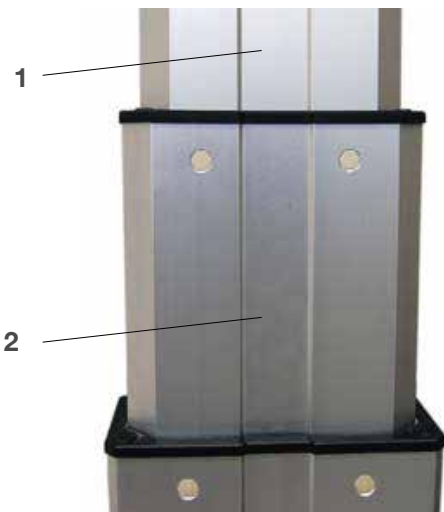

6.5 Connection to the control unit

CAUTION

The main connection must be fused by the customer to satisfy chapter 8.11.5 of IEC 60601-1. If fuses complying with IEC 60127 are used and the prospective short-circuit current exceeds 35 A or 10 times the current rating of the fuse, whichever is greater, the fuse should have high breaking capacity (1 500 A).

All control units not approved by Ewellix for the telescopic devices are third party controls.

NOTICE

Material damage due to third-party control!

The use of a third-party control may lead to material damage. If a third-party control unit is used, the manufacturer does not assume any liability for damage that may be caused. Therefore:

- Only use Ewellix control units.
- If you must use a third-party control unit, please contact Ewellix.

WARNING

- By the use of a third-party control unit, the secondary 24 V DC electric circuit must be proper separated from the main without connection to earth ground.

NOTE

A low-voltage plug connects the device to an external control unit. Comply with instructions in the operating manual of the Ewellix Control unit during the connection process.

Depending on the version, the low-voltage plug has been fitted with a jack or DIN-8 plug.

6.5.1 Connect jack plug to control unit

Special tools required:

- Special tool from the manufacturer (part no. ZBG-140375 (0125322)).

1. Check the sealing ring of the jack plug (arrow) and the plug for damage.

NOTE

Damaged sealing rings and twisted plugs may no longer provide protection pursuant to IPX6S. They have to be replaced by Ewellix (refer to chapter ↳ 5 Transport, packaging and storage).

Fig. 18

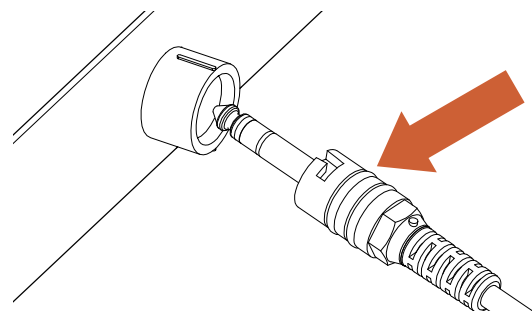

2. Lightly lubricate sealing ring with Klübersynth VR 69-252 (part no. 0118037).

NOTICE

Damage due to wrong lubricants!

The use of incorrect lubricants may cause significant material damage.

Therefore:

- Only use the lubricants authorized by Ewellix.

3. Insert jack plug with bayonet joint (2) into the connecting socket (1) of the control unit. Ensure correct positioning of the groove (3).

Fig. 19

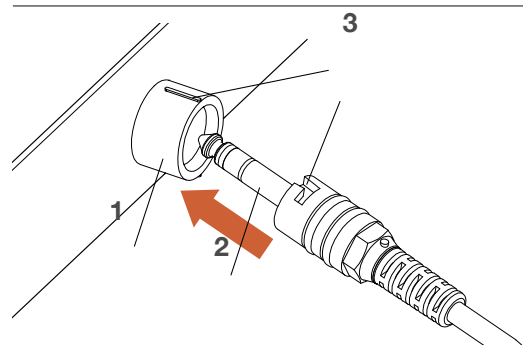

4. Insert special tool (1) in the nut (2) of the jack plug.

Fig. 20

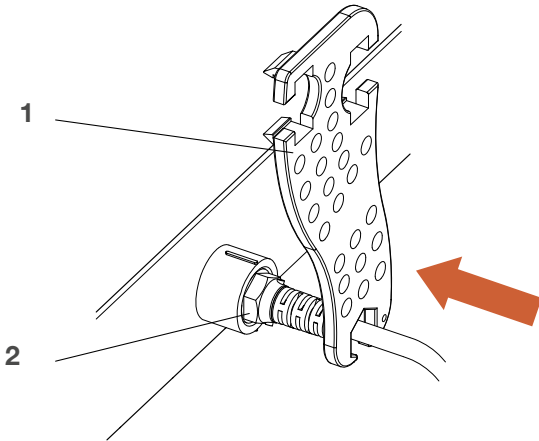

5. Turn special tool (1) clockwise until the bayonet joint of the jack plug is locked.

Fig. 21

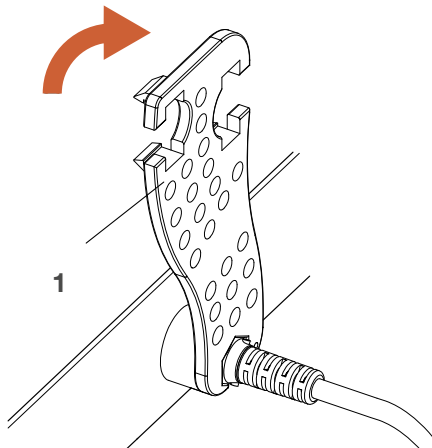

6.5.2 Connect DIN-8 plug to control unit

The insertion position is dictated by the geometric shape of the plug. The strain relief for this system is provided via attached components of the Ewellix control unit's casing.

1. Check the sealing ring of the DIN-8 plug (arrow) and the plug for damage.

Fig. 22

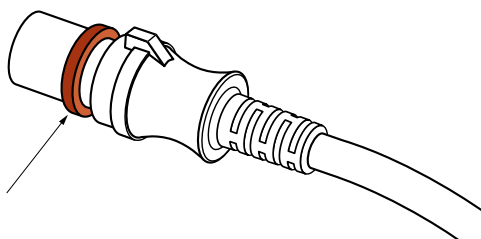

NOTE

Damaged sealing rings and twisted plugs can no longer provide protection pursuant to IPX6S. They have to be replaced by the manufacturer (refer to chapter 5.1 **Safety information for the transport**).

Connection, BCU control in this example

2. Lightly lubricate sealing ring (arrow) with Klübersynth VR 69-252 (part no. 0118037).

NOTICE

Damage due to wrong lubricants!

The use of incorrect additives may cause significant material damage.

Therefore:

- Only use the auxiliary products listed by the manufacturer.

3. Insert DIN-8 plug (3) into the connecting socket (1) of the control unit. Ensure correct positioning of the groove (2) and the lug (4).

Fig. 23

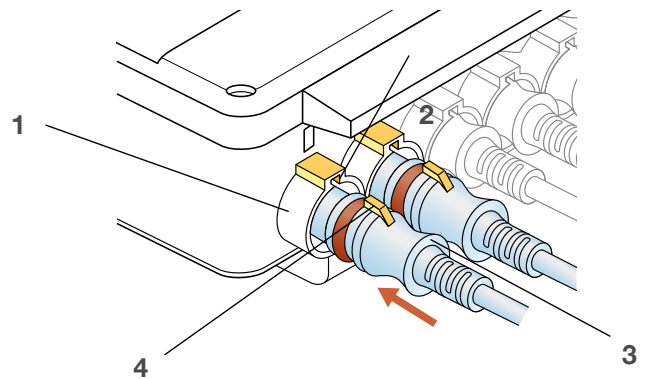

7.0 Operation

7.1 Safety

Improper operation

⚠ WARNING

Danger of injury from improper operation

Improper operation can result in serious injury and significant damage to property.

Therefore:

- Carry out all operating steps in accordance with the specifications and instructions in this manual and in manuals for options.
- Before operating, ensure that
 - all covers and safety devices are installed and functioning properly.
 - no persons are in the danger zone.
- Never disable or bypass safety devices during operation.

Moving parts

⚠ WARNING

Danger of injury from moving parts

Rotating parts and/or parts moving in linear fashion may cause serious injuries.

Therefore:

- During operation, do not reach into or touch moving parts.
- Do not open covers during operation.
- Before opening the covers, make sure that all parts have stopped moving.
- When in the danger zone, wear close-fitting protective work clothing with low tear strength.
- Note, that the actuator over travels after stop command from the operating element is in dependence from speed.

NOTICE

Damage due to static and dynamic overload of the pillar

Static and dynamic overload may damage the device and lead to its failure.

Therefore:

- Adhere to maximum permissible operating data for the pillar (↳ **Appendix A “Technical data”**).
- Never exceed nominal load.
- Never tamper with the elements connected to the pillar while it is in operation.
- Ensure that there are no objects in the lift area of the pillar while it is in operation.

NOTICE

Damage due to penetrating liquids

- Ensure that no liquids touch the inner guide tubes.

NOTICE

Material damage through overheating

An overheating of the pillar can cause damage.

Therefore:

- Only use a control unit with an integrated thermal switch.
- Never exceed nominal load.
- Always adhere to idle and operating periods in manual (refer to chapter ↳ **3.2 Operating conditions**).

7.2 Turn on and off



NOTE

The device does not feature its own operating elements.

A separate operating element is used to turn the device on and off (↳ **element's operating manual**) (↳ **separate operating manual**).

7.3 Precautions prior to use

1. User must ensure that there are no persons or objects in the lift area of the pillar
2. Ensure that the pillar is not dirty.

NOTICE

Damage due to contamination

Contamination of the device can cause serious damage.

Therefore:

- Clean dirty parts immediately (refer to chapter ↳ **8.3.1 Cleaning**).

7.4 Normal operation



NOTE

The device does not feature its own operating elements.

The operation takes place via a separated operating element (↳ **separate operating manual**).

7.5 Precaution after use

Disconnect device from power supply or turn off entire system control (↳ **separate manual**).

7.6 How to stop device in case of emergency

In hazardous situations, all movements of the device must be stopped as quickly as possible and the power supply must be turned off. The final application has to be constructed in a way that in emergency situations (like blocking) the patient can be set free by means of a appropriately solution or operation. Follow stopping procedures below.

7.6.1 Shut down the telescopic pillar

1. Immediately engage emergency shut-off, if present.
2. Pull the power line plug of the control unit out of the power outlet
3. Pull the low-voltage plug (Jack plug or DIN-8 plug) of the cable of the device out of the connecting socket of control unit (refer to chapter ↳ **6.5.1 and 6.5.2**).
4. Evacuate people from the hazard zone, initiate first aid measures.
5. Notify doctor and fire department, if necessary.
6. Notify responsible person on-site.
7. Keep access paths open for rescue vehicles.
8. Based on severity of emergency, notify the authorities if necessary.
9. Order specialized staff to repair malfunction.
10. Check the device and application that uses the device prior to restarting the operation and ensure that all safety equipment is installed and fully functional. and that there are no persons in the hazard zone.

⚠ WARNING

Life-threatening situation due to premature restart!

A premature restart may present a life-threatening situation for all persons in the hazard zone.

Therefore:

- Ensure prior to the restart that there are no persons in the hazard zone.

7.6.2 Pull jack plug out of the KOM control unit

Proceed as follows to pull jack plug out of the connection outlet of the control unit:

- Special tools required:
 - Special tool from the manufacturer (part no. 0100609)

Connection, KOM control in this example

1. Insert special tool (1) in the groove (2) of the jack plug.

Fig. 24

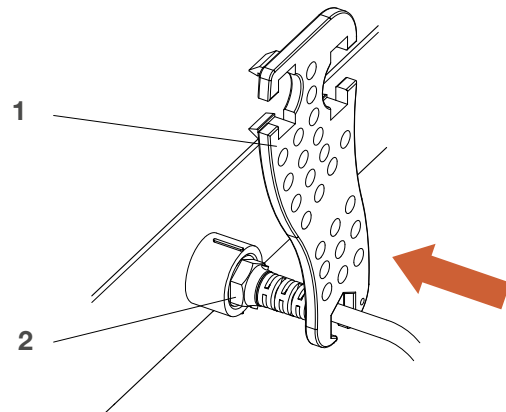

2. Turn special key (1) counter-clockwise until the bayonet joint of the jack plug is unlocked.

Fig. 25

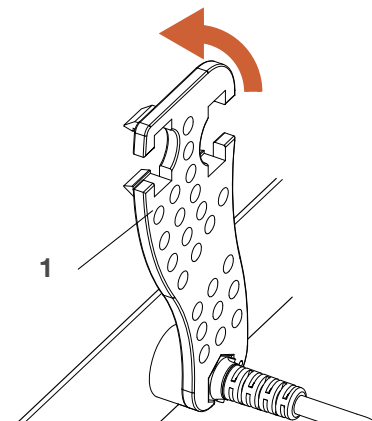

3. Pull jack plug (1) out of the connection outlet (2) of the control unit (arrow).

Fig. 26

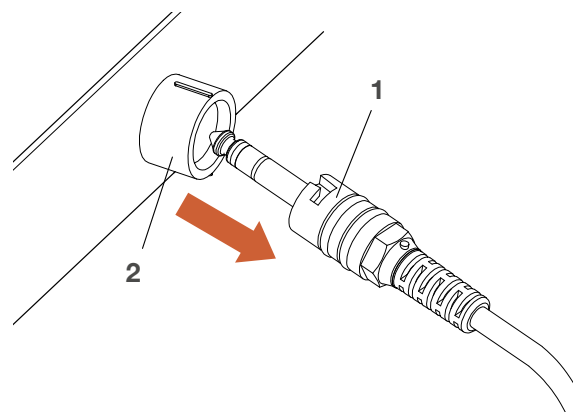

7.6.3 Pull the DIN-8 plug out of the BCU/VCU/SCU control unit

BCU control

Proceed as follows to pull DIN-8 plug out of the connection socket of the control unit:

1. press with a screw driver into to hole (1) to release the cover to lift up and remove it:

Fig. 27

BCU control



2. Hold the control firmly and pull the DIN-8 plug (1) out of it.

Fig. 28

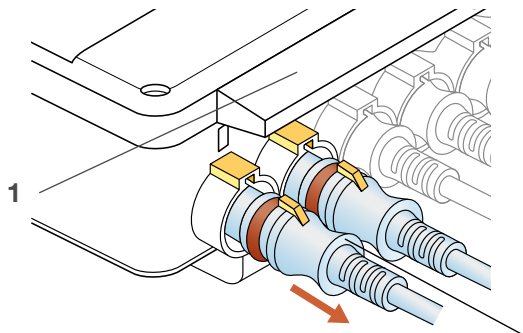

VCU and SCU control

1. Loosen and remove the screw (1).
2. Lift up the cover (2) and remove it.

Fig. 29

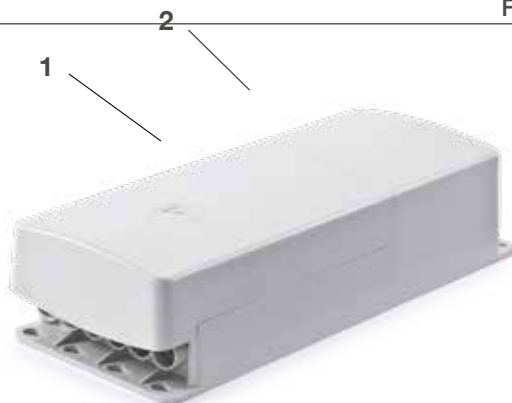

3. Hold the control firmly and pull the DIN-8 plug (1) out of it.

Fig. 30

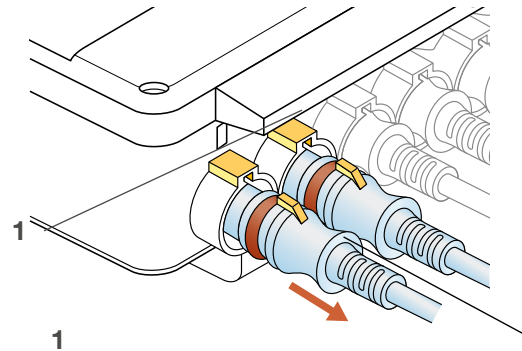

7.7 After use

Disconnect the pillar from the power supply or switch off the control (↳ **Separate operating manual for the control**).

8.0 Maintenance

8.1 Safety

Electrical equipment

⚠ WARNING

Life-threatening danger due to electric shock or electrocution and crush hazards.

There is a life-threatening hazard when touching live components. Also, live electrical components can move unexpectedly and can cause serious injuries.

Therefore:

- Prior to starting work, switch off the power supply and safeguard it from being re-started.

Safeguarding against restart

⚠ WARNING

Life-threatening danger if restarted without authorization!

When correcting faults, there is danger of the energy supply being switched on without authorization. This poses a lifethreatening hazard for persons in the danger zone.

Therefore:

- Prior to starting work, switch off the power supply and safeguard it from being switched on again.

Moving parts

⚠ WARNING

Risk of injury through moving parts

Rotating and/or linear moveable components can cause serious injuries.

Therefore:

- Turn off pillar and if necessary, protect it against being turned on again before conducting any maintenance work on moveable components.

8.2 Maintenance plan

The sections below describe the maintenance work required on the pillar to help provide optimal and smooth operation of the device.

If increased wear or dirt is found during regular checks, the required maintenance intervals should be shortened.

Contact the manufacturer in the event of inquiries regarding maintenance work and intervals; see the service address on the back cover page.

Interval	Maintenance work	To be carried out by
Daily	Clean dust and dirt off the pillar (refer to chapter ↪ 8.3.1 Cleaning).	Operator
	Check pillar for visible damage (refer to chapter ↪ 8.3.2 Visual check of condition).	Qualified personnel
Monthly	Function check of operating features and safety equipment. Check the attachment of the device to the upper and lower attachment plates.	Qualified personnel
Every 6 months	Check the function of the emergency cut-off switch, if present. Check all plugs to be sure they are properly inserted.	Qualified electrician Operator
Definition through the processor	Conduct visual inspection of the condition of the permanent safeguard and the routing of the supply and control cable within the application. Cable routing elements should not be loose or broken.	Qualified electrician



NOTE

If the telescopic pillar is used outside of the specified environmental conditions, check all components that are directly exposed to these environmental conditions monthly for visual changes (such as oxidation or sedimentation).

8.3 Maintenance work

Improper cleaning

NOTICE

Damage due to incorrect cleaning!

Incorrect cleaning may lead to significant material damage.

Therefore:

- Do not use any aggressive cleaning agents. Water used for cleaning, including the chemical additives, must be pH-neutral.
- Only use the auxiliary materials listed by the manufacturer.
- Do not treat emergency lowering mechanism for quick adjustment system with oil, grease or other lubricants.
- No steam jets or pressure washers may be used for cleaning.
- Other cleaning agents or cleaning devices may only be utilized with the manufacturer's approval.

8.3.1 Cleaning

8.3.1.1 Cleaning of THG, TLG, TLT1

1. Turn off pillar and secure against restart.
2. Clean dirty parts with a damp, lint-free cloth.

8.3.1.2 Cleaning of TLT2

1. Turn off pillars and secure against restart
2. Clean dirty parts with damp , lint-free cloth
3. Secure that no liquids can enter or come in contact with the electronic parts (motor, printed circuit boards, wiring) and dos not enter into the pillar.

8.3.2 Visual inspection

1. Turn off device and secure against restart.
2. Check the following components (↳ **fig. 31**).
 - Guiding tubes (1) for scratches, bumps, cracks and gaps .
 - Connection sockets for visible exterior damage.
 - In case of damage, contact manufacturer (For address ↳ **Cover page**).

Fig. 31

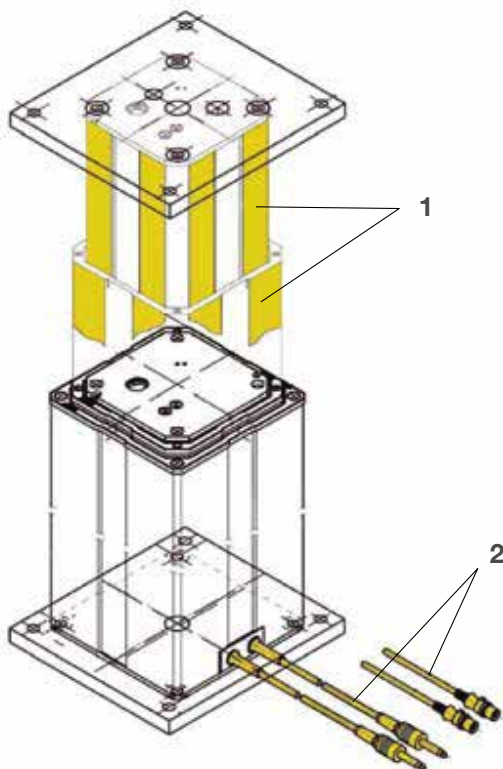

Visual inspection

1. Guiding tubes
2. Connecting cable for jack or DIN8 plug

3. Relubricate the sliding surfaces if necessary (please contact Ewellix).
4. In case of damage, inform the person responsible for further machining or the manufacturer.

8.4 Actions after maintenance has been completed

After completing the maintenance work and before operating the device, carry out the following steps:

1. Check that all previously loosened threaded connections are tight.
2. Check that all previously removed safety devices and covers have been replaced properly.
3. Check that all tools, materials and other equipment used for maintenance have been removed from the work area.
4. Clean the work area and remove any substances which may have escaped, such as liquids or processing material.
5. Ensure that all the appliance's safety devices are completely functional.
6. Document the inspections and maintenance in the service log.

9.0 Malfunctions

The following chapter describes the possible causes of faults, and the work required to fix them.

In the event of repeated faults, shorten the maintenance intervals in accordance with the actual load.

Contact the manufacturer in the event of faults which cannot be fixed in accordance with the instructions below; see the service address on the back cover page.

9.1 Safety

Electrical equipment

WARNING

Life-threatening danger due to electric shock or electrocution and crush hazards.

There is a life-threatening hazard when touching live components. Also, live electrical components can move unexpectedly and can cause serious injuries.

Therefore:

- Prior to starting work, switch off the power supply and safeguard it from being re-started.

Safeguarding against restart

WARNING

Life-threatening danger if restarted without authorization!

When correcting faults, there is danger of the energy supply being switched on without authorization. This poses a lifethreatening hazard for persons in the danger zone.

Therefore:

- Prior to starting work, switch off the power supply and safeguard it from being switched on again.

Incorrect repair of malfunction

WARNING

Risk of injury and material damage due to incorrect repair of malfunction

The telescopic pillar is not designed for repair work. Incorrect repair of a malfunction may lead to personal injury or material damage.

Therefore:

- Never loosen the screws on the telescopic pillar or try to open the telescopic pillar.

When a malfunction occurs, do the following:

1. In the event of 1 a malfunction that may present an immediate danger to persons or assets, turn off the pillar or control unit immediately and safeguard against a restart.
2. Determine cause of malfunction.
3. Depending on the type of a malfunction, have it repaired by authorized qualified personnel or fix it yourself.
4. Inform responsible party on-site concerning malfunction.

9.2 Troubleshooting chart



NOTE

The following troubleshooting chart provides information as to who is authorized to repair the respective defect.

Fault description	Cause	Remedy	Personnel
Telescopic pillar does not move	No supply voltage.	Check power supply.	Qualified electrician.
	Lack of plug contact or plug has not been inserted properly.	Plug contacts: Check pillar control, voltage grid control, control of operating element. Reinsert plug.	User.
	Defective power cable or plug.	Supply cable and plug of the lines: Check pillar control, voltage grid control, control of operating element for damage.	Qualified electrician.
	Obstacle in the lift area of the pillar.	Remove all obstacles in the lift area.	User.
	Incorrect control unit.	Compare the specification on the control unit's label with the device label. If the manufacturer of the control unit is not approved for the Telemag telescopic pillar, replace it with an authorized one.	Qualified personnel.
	Incorrect service load.	Measure static and dynamic load and compare with information concerning the type sign. If the service load is exceeded, check the nominal load. Do not exceed.	Qualified personnel.
Telescopic pillar does not move	Defective control unit/ operating element.	Carry out troubleshooting of Ewellix control unit. If necessary, replace defective control unit/ operating element.	Qualified personnel.
	Lifespan of the pillar is exceeded.	Replace the pillar, if the pillar is older than 10 years or it has carried out more than 20,000 double lifts with a lift of 300 mm.	Qualified personnel.
	The telescopic pillar cannot be moved by any of the measures listed above.	Replace telescopic pillar, contact the manufacturer.	Qualified personnel.
The pillar cannot be operated	Defective Ewellix operating element.	Carry out troubleshooting of the Ewellix operating element. If necessary, replace operating element.	Qualified personnel.
	Incorrect operating element.	Compare the specification on the operating element's label with the device label. If the manufacturer of the operating element is not authorized for the pillar, replace it with an authorized one.	Qualified personnel.

9.3 Start of operation after fault has been eliminated

To restart equipment after fault has been corrected, follow instructions in the **Installation chapter**.

Fault description	Cause	Remedy	Personnel
The telescopic pillar cannot be lifted	Obstacle in the lift area of the telescopic pillar.	Remove all obstacles in the lift area.	User.
	Incorrect service load.	Remove all loads that are on the element. Then check the pillar.	Qualified personnel.
	Defective motor, gear or ball screw nut.	Remove all loads that are on the elements, check the pillar after that.	Qualified personnel.
Significantly reduced speed	Obstacle in the lift area of the pillar.	Remove all obstacles in the lift area.	User.
	Incorrect service load.	Remove all loads that are on the elements, check the pillar after that.	Qualified personnel.
Significantly increased operating noise	Obstacle in the lift area of the pillar.	Remove all loads that are on the element. Then check the pillar.	Qualified personnel.
	Incorrect service load.	Remove all loads that are on the elements.	User.
	Defective motor, gear or ball screw nut.	Replace pillar.	Qualified personnel.
Play in the guiding system	Sliding elements are worn.	Replace pillar.	Qualified personnel.

10.0 Dismantling and disposal

Following the end of its useful life, the appliance must be uninstalled and disposed of in accordance with the local environmental regulations.

10.1 Safety

Improper dismantling

⚠ WARNING

Danger of injury due to improper dismantling

Stored residual energy, angular components, points and edges on and in the appliance or on the tools needed to uninstall can cause injuries.

Therefore:

- Ensure there is sufficient space before starting work.
- Handle exposed, sharp-edged components with care.
- Pay attention to orderliness and cleanliness in the workplace! Loosely stacked or scattered components and tools could cause accidents.
- Uninstall the components properly. Note that some components may have a high intrinsic weight. Use hoists if necessary.
- Secure components so that they cannot fall down or topple over.
- Contact the manufacturer if in doubt.

10.2 Dismantling

10.2.1 Dismantling the telescopic pillar

1. Disconnect the device's control from the power supply.
2. Pull the jack or DIN-8 plug of the telescopic pillar out of the control unit.
3. Secure elements of the application so that no loads act on the attachment plates.
4. Loosen and remove the screws for the application/attachment plates of the telescopic pillar or application on the upper and lower side of the telescopic column.
5. Disconnect the telescopic pillar from the elements of the applications.
6. Loosen and remove any attachment screws present for the attachment plates.
7. Clean the device.

8. Carefully pack the device for shipment to the manufacturer (refer to chapter 5.3 Return shipment to the manufacturer).

10.2.2 Pull the jack out of the KOM control unit

Proceed as follows to pull jack out of the connection socket of the control unit:

- Special tools required:
 - Special tool from the manufacturer (part no. ZBG-140375 (0125322))
- 1. Insert special tool (1) in the groove (2) of the jack plug.

Fig. 32

Connection, KOM control in this example

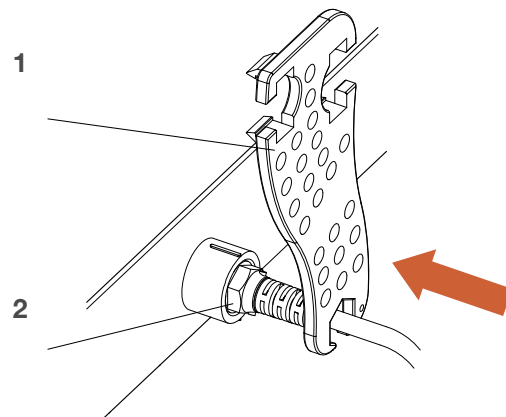

2. Turn special key (1) counter-clockwise until the bayonet joint of the jack plug is unlocked.

Fig. 33

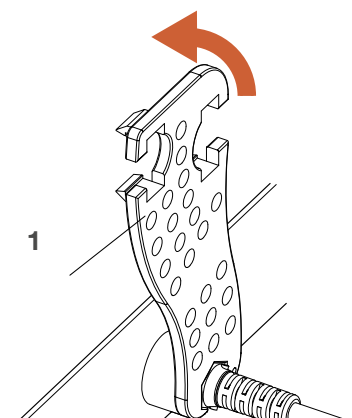

3. Pull jack plug (1) out of the connection outlet (2) of the control unit (arrow).

Fig. 34

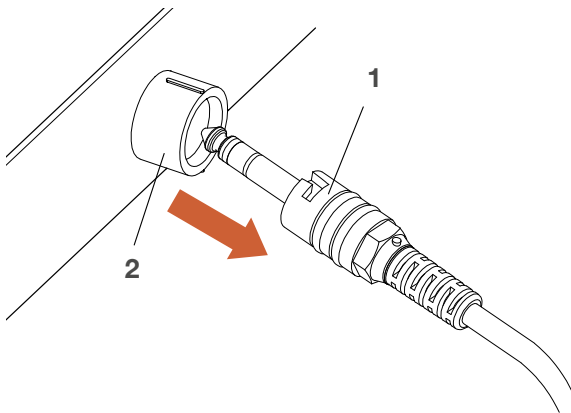

10.2.3 Pull the DIN-8 plug out of the BCU/ VCU/SCU control unit

BCU control

Pull DIN-8 plug out of the connection socket of the control unit:

1. press with a screw driver into to hole (1) to release the cover to lift up and remove it:

Fig. 35



2. Hold the control firmly and pull the DIN-8 plug (1) out of it.

Fig. 36

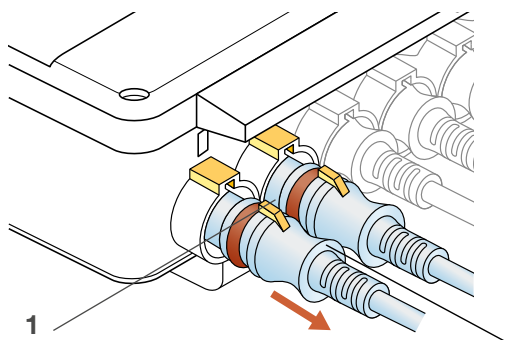

VCU and SCU control

1. Loosen and remove the screw (1).
2. Lift up the cover (2) and remove it.

Fig. 37



3. Hold the control firmly and pull the DIN-8 plug (1) out of it.

Fig. 38

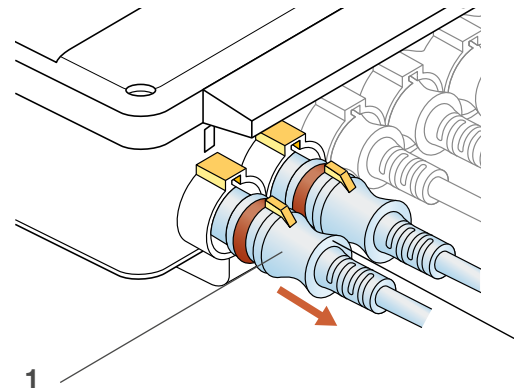

10.3 Disposal

For the disposal, uninstall the device according to applicable local occupational health and environmental regulations (refer to chapter [10 Dismantling and disposal](#)).

For disposal, clean component groups and components professionally and in accordance with applicable local occupational health and environmental regulations.

If no return or disposal agreement has been made with Ewellix, send the uninstalled components to a licensed recycler for recycling.

⚠ CAUTION

Incorrect disposal can cause environmental damage

Therefore:

- Electrical scrap, electronic components, lubricants and other auxiliary materials must be disposed of by authorised recycling companies.
- If in doubt, obtain information about disposal in accordance with the environmental regulations from the local municipal authorities or specialised waste disposal companies.

11.0 Appendix

Technical data sheets

The following pages are a reprint from:

THG: **PUB NUM IL-07009/1-EN-March 2020**

TLG: **PUB NUM IL-07021/1-EN-March 2020**

TLT1: **PUB NUM IL-07011/1-EN-March 2020**

TLT20: **PUB NUM IL-07024-EN-May 2020**

THG

Telemag telescopic pillar

Benefits

- Compact design
- Robust

Standards

- EN/IEC 60601-1
- UL 60601-1



Technical data

	Unit	THG 10/11-BA	THG 10/11-CA	THG 10/11-BD	THG 10/11-CD
Rated push load	N	2 000	1 000	2 000	1 000
Rated pull load	N	0	0	0	0
Bending load	Nm	up to 250 ¹⁾	up to 120 ¹⁾	up to 1 000 ¹⁾	up to 450 ¹⁾
Speed (full load to no load)	mm/s	5 to 7	12 to 15	5 to 7	12 to 15
Telescopic pillar version	# of section	2-section	2-section	3-section	3-section
Stroke	mm	200 to 700	200 to 700	200 to 700	200 to 700
Retracted length	mm	S+270	S+270	S+180	S+180
Voltage	V DC	24	24	24	24
Power	W	120	120	120	120
Current	A	5	5	5	5
Duty cycle: intermittent operation	min.	1 min./9 min	1 min./9 min	1 min./9 min	1 min./9 min
Ambient temperature	°C	+10 to +40	+10 to +40	+10 to +40	+10 to +40
Type of protection	IP	30	30	30	30
Protection class	-	SELV	SELV	SELV	SELV
Type of control	-	electrical	electrical	electrical	electrical
Weight	kg	8 to 14	8 to 14	8 to 14	8 to 14

¹⁾ For details, please see bending load diagrams (↳ page 38)

Dimensional drawing

2-section

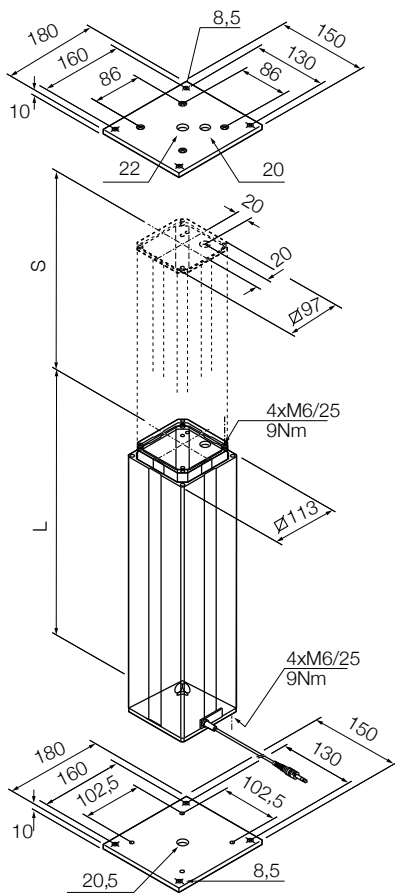

3-section

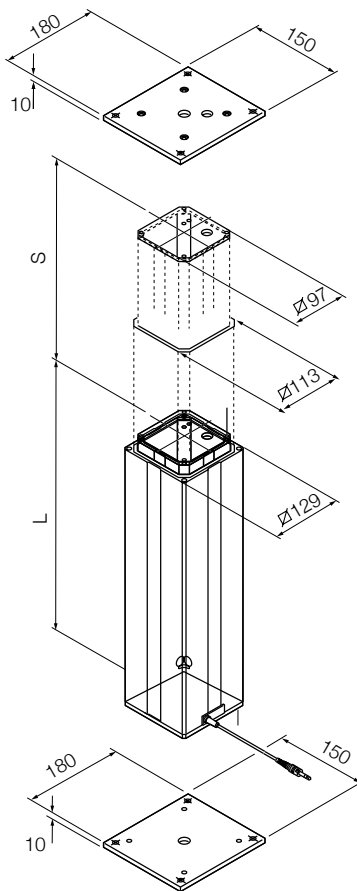

Note: mounting plates are not included. To be ordered separately.

Legend:

S = stroke

L = retracted length

Connection diagram¹⁾

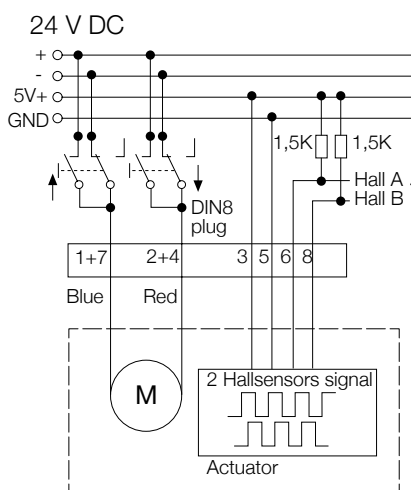

Suitable control units and accessories

THG	Control units			
	SCU	VCU	BCU	MCU
Operating switches				
EHA 1				●
EHA 3	●	●	●	
STF				●
STJ	●	●	●	
STA				●
STE	●	●	●	

Hand switch

Foot switch

Desk switch

¹⁾ Only valid with THG11. THG10 must be operated by a BCU, SCU or VCU control unit.

Performance diagrams

Speed-load diagram

Speed (mm/s)

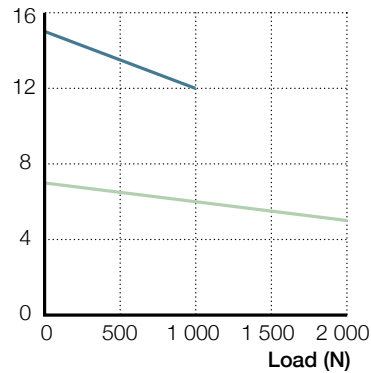

Current-load diagram

Current consumption (A)

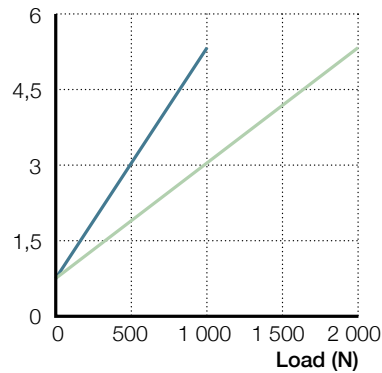

Safety factor load conditions

Safety factor (screw buckling)

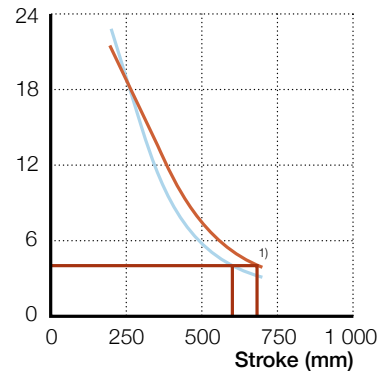

1) Safety factor = 4

— THG...B. — THG...C.

— B/Tr 15x5 — C/Tr 12,5x5

Bending load diagrams

Bending load diagram THG...BD

Load [N]

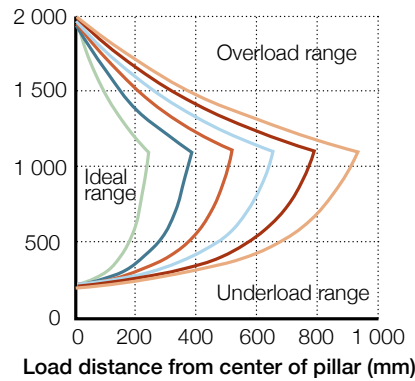

Bending load diagram THG...CD

Load [N]

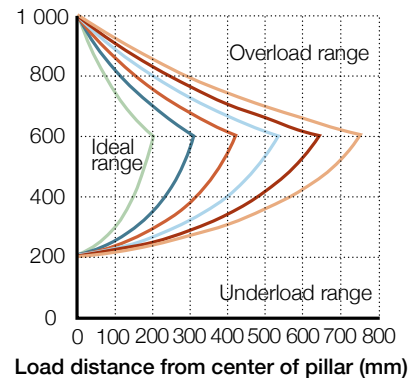

Bending load diagram THG...BA/CA

Load [N]

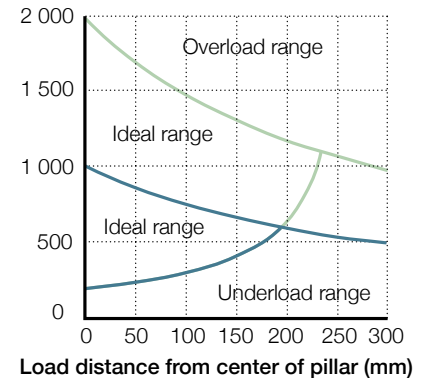

Stroke: — 200 — 300 — 400 — 500 — 600 — 700

— THG...BA — THG...CA

Accessories

	Designation	Order number
Top mounting plate for 2× tube set	SPL-264265	0125688
Bottom mounting plate for 2× tube set	SMT-264363	0124814
Top mounting plate for 3× tube set	SPL-264265	0125688
Bottom mounting plate for 3× tube set	SPL-264237	0125623
Screw M6x30 (4/plate) for mounting plate	ZBE-510707	0125622
Plug AC Telemag 3 pin	ZBE-510709	0125560

Ordering key

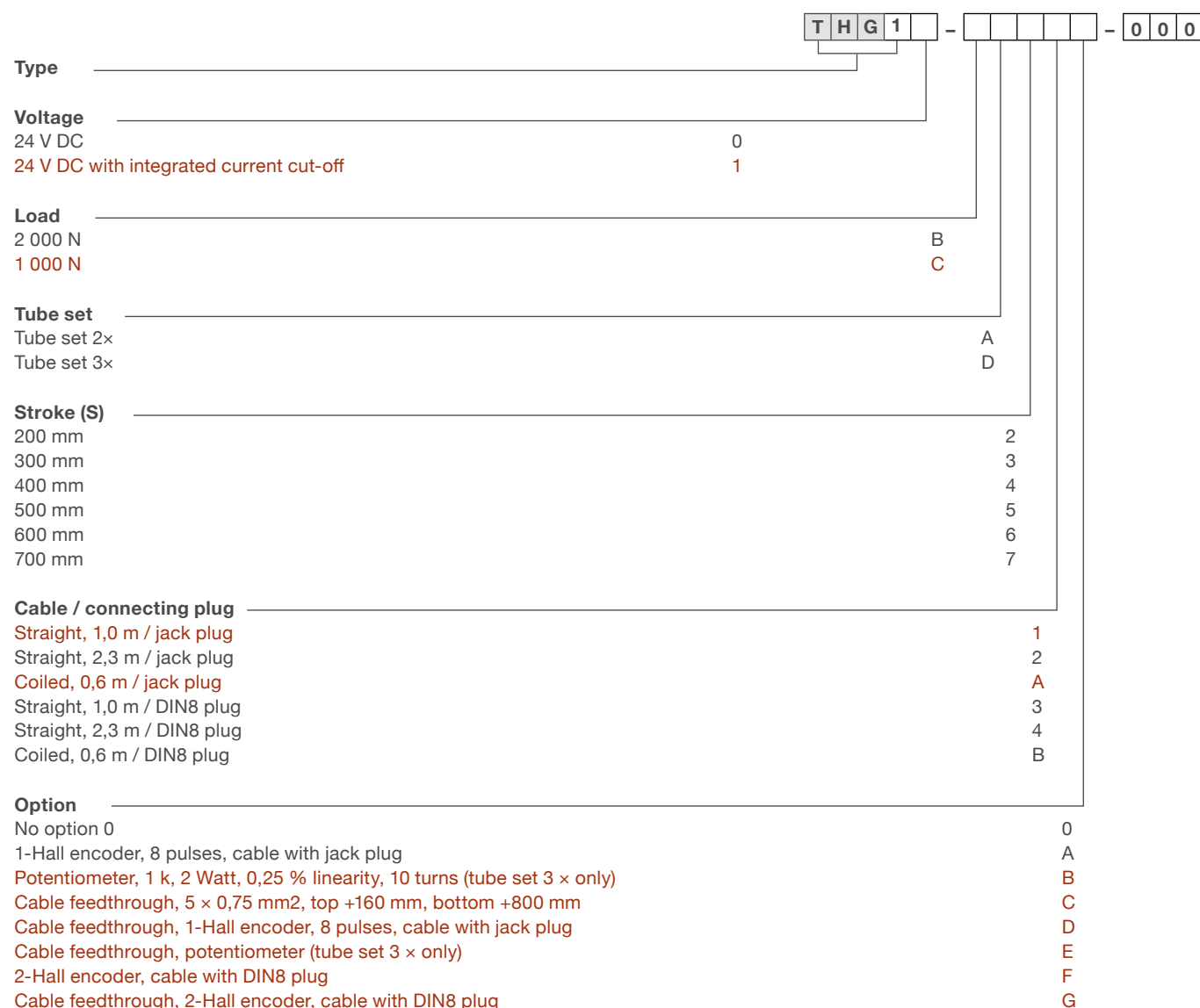

Options shown in yellow are only available on request. Contact Ewellix for more information on minimum quantities and additional costs.

TLG

Telemag telescopic pillar



Benefits

- High bending load
- Powerful

Standards

- EN/IEC 60601-1
- UL 60601-1

Technical data

	Unit	TLG 10/11-A	TLG 10-B	TLG 10/11-C
Rated push load	N	4 000	2 500	1 500
Rated pull load	N	0	0	0
Bending load	Nm	up to 2 800 ¹⁾	up to 1 750 ¹⁾	up to 950 ¹⁾
Speed (full load to no load)	mm/s	10 to 14	13 to 17	25 to 33
Telescopic pillar version	# of section	2 or 3-section	2 or 3-section	2 or 3-section
Stroke	mm	200 to 700	200 to 700	200 to 700
Retracted length	mm	S+180	S+180	S+180
Voltage	V DC	24	24	24
Power	W	156	156	156
Current	A	6	6	6
Duty cycle: intermittent operation	min.	1 min./9 min	1 min./9 min	1 min./9 min
Ambient temperature	°C	+10 to +40	+10 to +40	+10 to +40
Type of protection	IP	30	30	30
Protection class	–	SELV	SELV	SELV
Type of control	–	electrical	electrical	electrical
Weight	kg	15 to 30	15 to 30	15 to 30

¹⁾ For details, please see bending load diagrams (↳ page 42)

Dimensional drawing

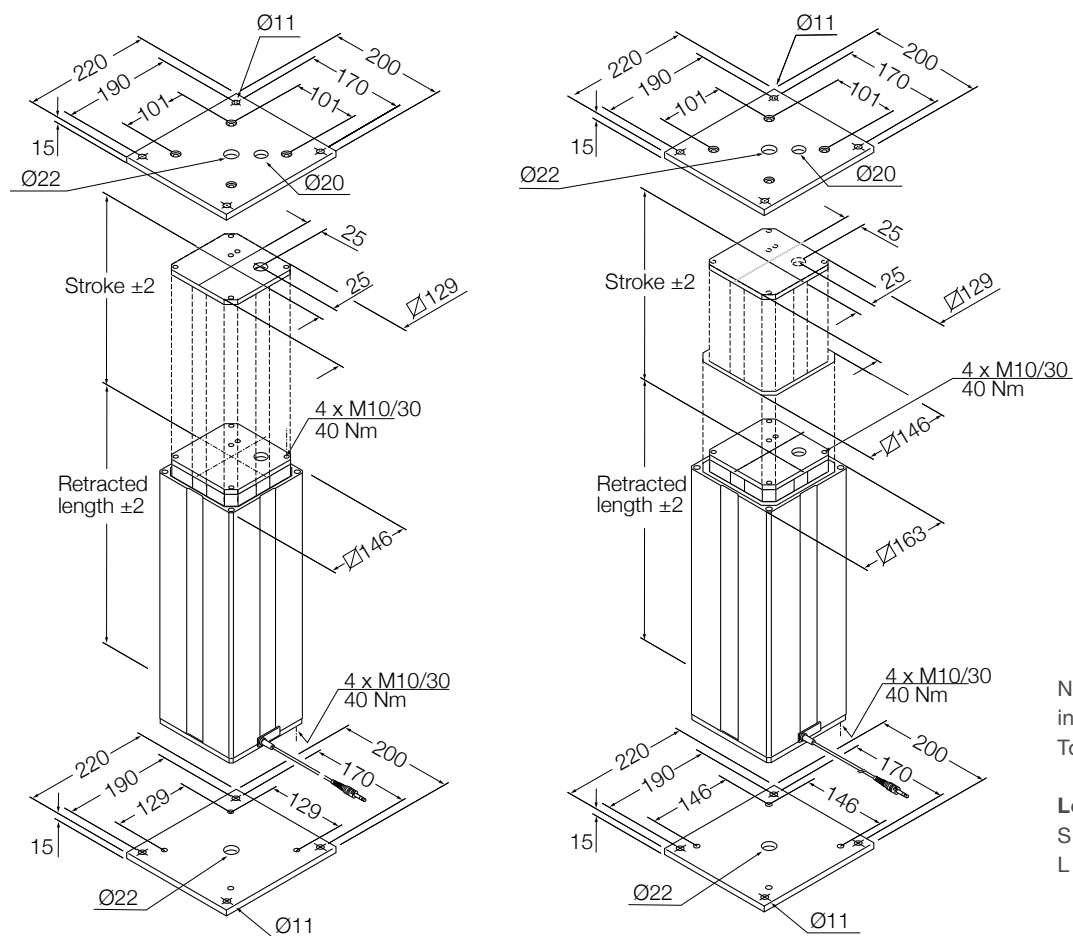

Note: mounting plates are not included.
To be ordered separately.

Legend:
S = stroke
L = retracted length

Connecting diagrams

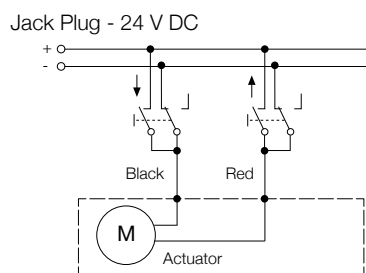
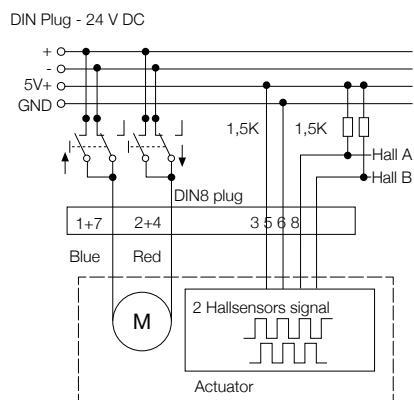

Suitable control units and accessories

	Control units			
	SCU	VCU	BCU	MCU
TLG	●	●	●	●
Operating switches				
EHA 1				●
EHA 3	●	●	●	
STF				●
STJ	●	●	●	
STA				●
STE	●	●	●	

Hand switch
 Foot switch
 Desk switch

¹⁾ Only valid with TLG11. TLG10 must be operated by a BCU, MCU, SCU or VCU control unit.

Performance diagrams

Safety factor load conditions

Speed-load diagram

Speed [mm/s]

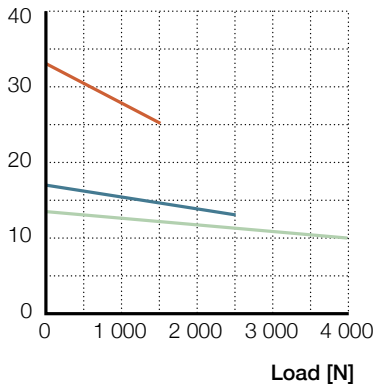

Current-load diagram

Current consumption [A]

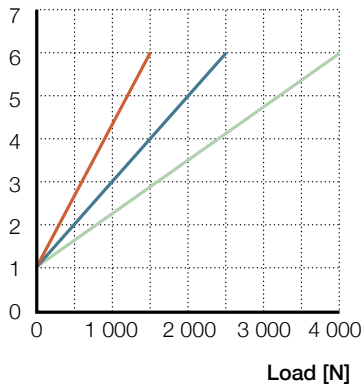

Safety factor

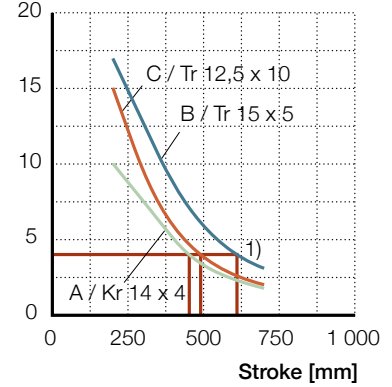

— A — B — C

1) Safety factor =4

Bending load diagrams

Bending load diagram TLG ...AD

Load [N]

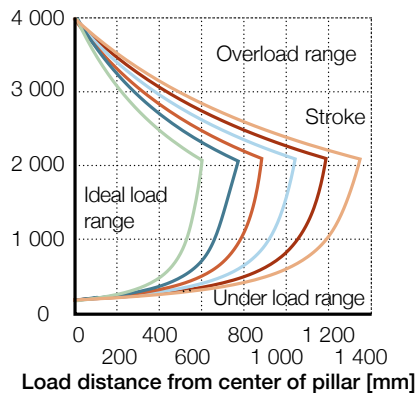

Bending load diagram TLG ...BD

Load [N]

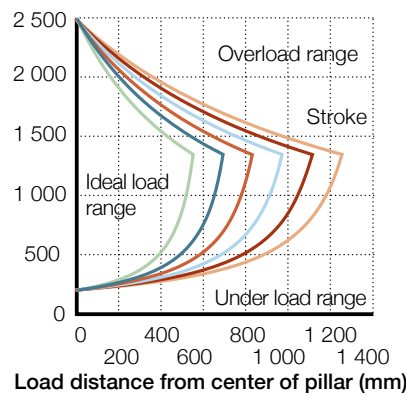

Bending load diagram TLG ...CD

Load [N]

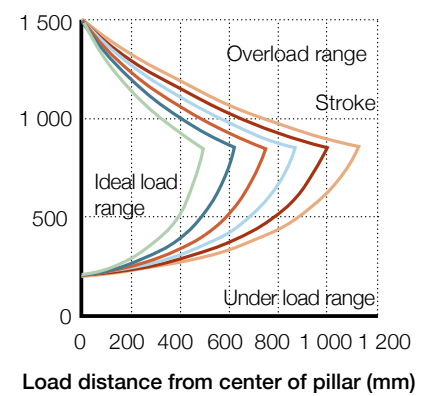

Stroke: — 200 — 300 — 400 — 500 — 600 — 700

Bending load diagram TLG...AA/BA/CA

Load [N]

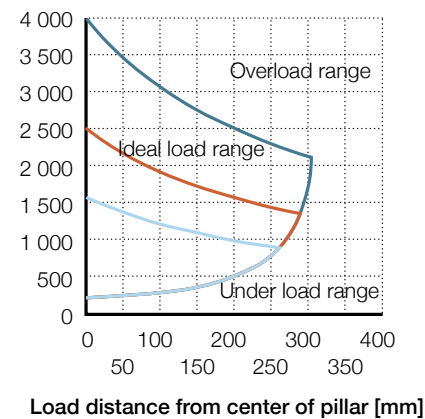

— TLG1-AA
— TLG1-BA
— TLG1-CA

Accessories

	Designation	Order number
Top mounting plate for 2 × tube set	ZPL-290268	0125624
Bottom mounting plate for 2 × tube set	ZPL-290351	0125625
Top mounting plate for 3 × tube set	ZPL-290268	0125624
Bottom mounting plate for 3 v tube set	ZPL-290265	0125623
Screw (4/plate) for mounting plate	ZBE-510707	0125360

Ordering key



Type		
Voltage		
24 V DC		0
24 V DC with integrated current cut-off (only for 4 000 N and 1 500 N load version)		1
Load		
4 000 N	A	
2 500 N	B	
1 500 N	C	
Tube set		
Tube set 2×	A	
Tube set 3×	D	
Stroke [S]		
200 mm		2
300 mm		3
400 mm		4
500 mm		5
600 mm		6
700 mm		7
Cable / connecting plug		
Straight, 1,0 m / jack plug		1
Straight, 2,3 m / jack plug		2
Coiled, 0,6 m / jack plug	A	
Straight, 1,0 m / DIN8 plug		3
Straight, 2,3 m / DIN8 plug		4
Coiled, 0,6 m / DIN8 plug	B	
Option		
No option		0
1-Hall encoder, 8 pulses, cable with jack plug	A	
Potentiometer, 1 kΩ, 2 Watt, 0,25% linearity, 10 turns	B	
Cable feedthrough, 5 × 0,75 mm ² , led out, top +160 mm, bottom +800 mm	C	
Cable feedthrough, 1-Hall encoder, 8 pulses, cable with jack plug	D	
Cable feedthrough, potentiometer	E	
2-Hall encoder, cable with DIN8 plug	F	
Cable feedthrough, 2-Hall encoder, cable with DIN8 plug	G	

Options written in yellow are only available on demand. Contact Ewellix for more information on minimum quantities and additional costs.

TLT1

Telemag telescopic pillar

Benefits

- Very small built-in dimension
- Powerful

Standards

- EN/IEC 60601-1
- UL 60601-1



Technical data

	Unit	TLT10-A1	TLT10-A2	TLT10-B1	TLT10-C1	TLT10-C2
Rated push load	N	3 000	4 000	2 000	1 000	2 000
Rated pull load	N	0	0	0	0	0
Bending load	Nm	up to 400 ¹⁾	up to 1 000 ¹⁾	up to 250 ¹⁾	up to 110 ¹⁾	up to 480 ¹⁾
Speed (full load to no load)	mm/s	11 to 16	13 to 19	13 to 19	25 to 36	25 to 42
Telescopic pillar version	# of section	3-section	3-section	3-section	3-section	3-section
Stroke	mm	300 to 700	300 to 700	300 to 700	300 to 700	300 to 700
Retracted length	mm	0,5 × S+170	0,5 × S+240	0,5 × S+170	0,5 × S+170	0,5 × S+240
Voltage	V DC	24	24	24	24	24
Power	W	168	168	192	192	216
Current	A	2×3,5	2×3,5	2×4,5	2×4,5	2×4,5
Duty cycle: intermittent operation	min.	1 min./9 min	1 min./9 min	1 min./9 min	1 min./9 min	1 min./9 min
Ambient temperature	°C	+10 to +40	+10 to +40	+10 to +40	+10 to +40	+10 to +40
Type of protection	IP	40	40	40	40	40
Protection class	–	SELV	SELV	SELV	SELV	SELV
Type of control	–	electrical	electrical	electrical	electrical	electrical
Weight	kg	15 to 30	15 to 30	15 to 30	15 to 30	15 to 30

¹⁾ For details, please see bending load diagrams (↳ page 46)

Dimensional drawing

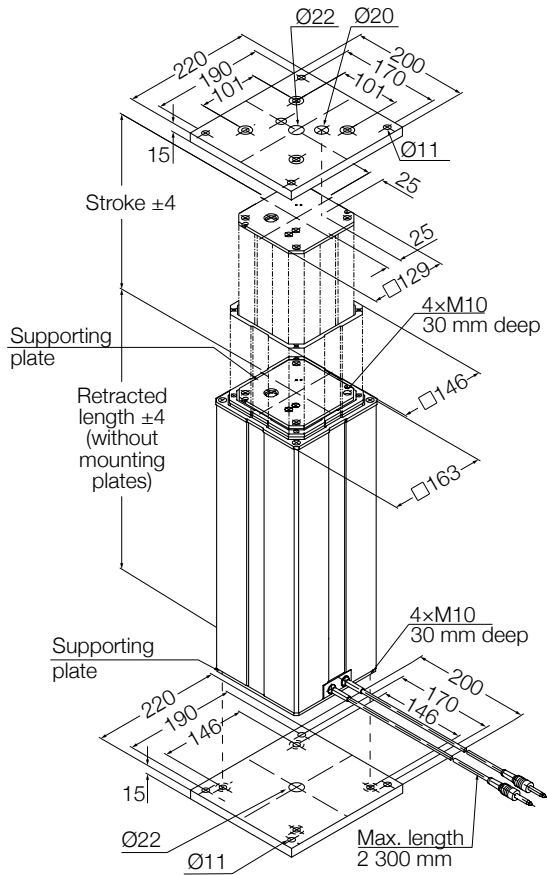

Note: mounting plates are not included. To be ordered separately.





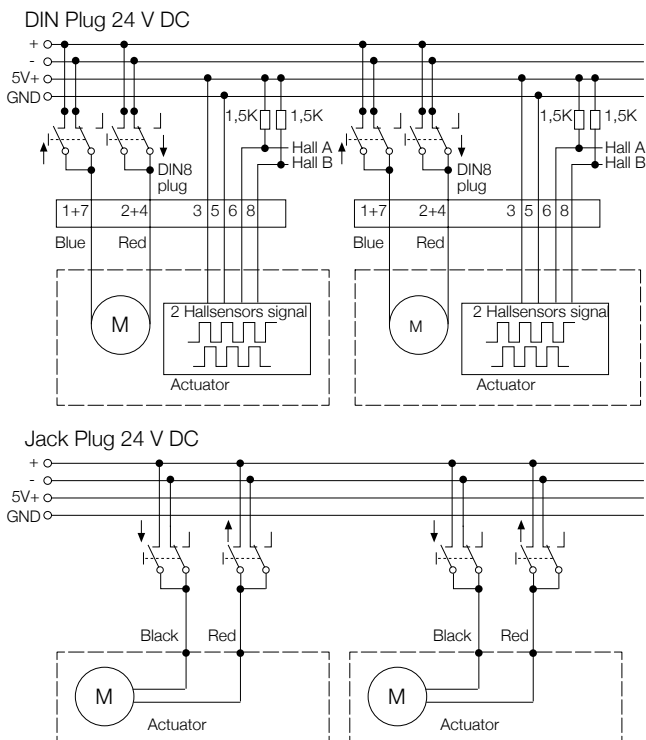

Legend:
 S = stroke
 L = retracted length



Connecting diagrams



¹⁾ Only valid with TLG11. TLG10 must be operated by a BCU, MCU, SCU or VCU control unit.

Suitable control units and accessories

	Control units			
	SCU	VCU	BCU	MCU
TLT	●	●	●	●
Operating switches				
EHA 1 				●
EHA 3 	●	●	●	
STF 				●
STJ 	●	●	●	
STA 				●
STE 	●	●	●	

 Hand switch
  Foot switch
  Desk switch

Performance diagrams

Speed-load diagram

Speed [mm/s]

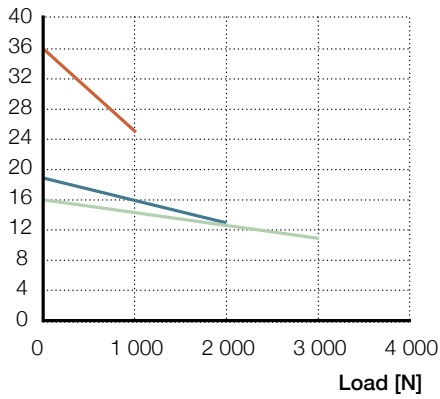

— A1 — B1 — C1

Current-load diagram

Current consumption [A]

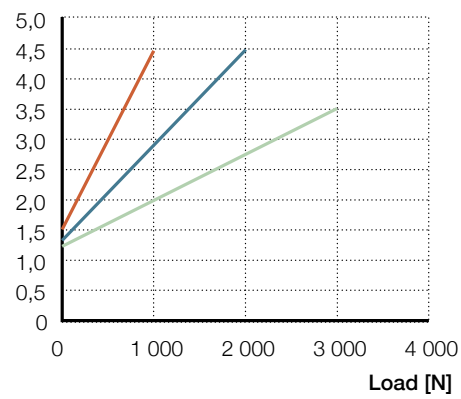

Speed-load diagram

Speed [mm/s]

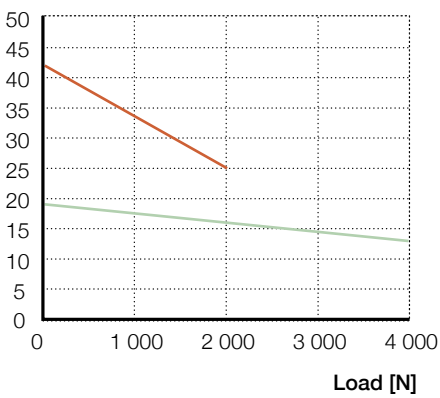

— A2 — C2

Current-load diagram

Current consumption [A]

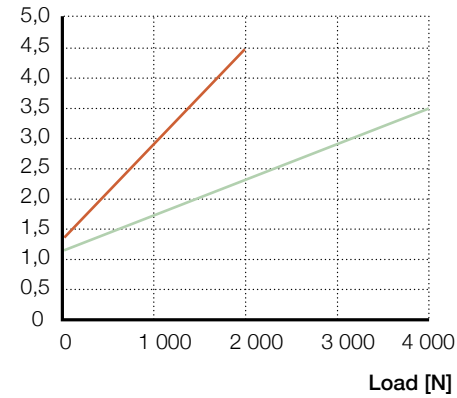

Bending load diagrams

Bending load diagram A1, B1, C1

Load [N]

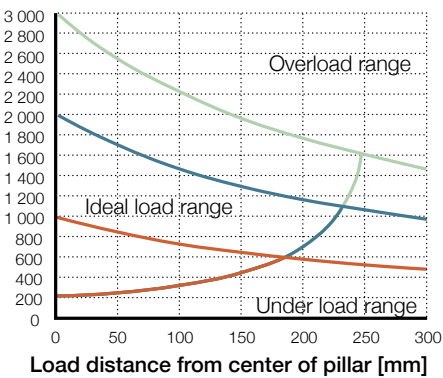

— TLT1 A-1 — TLT1 B-1 — TLT1 C-1

Bending load diagram A2, C2

Load [N]

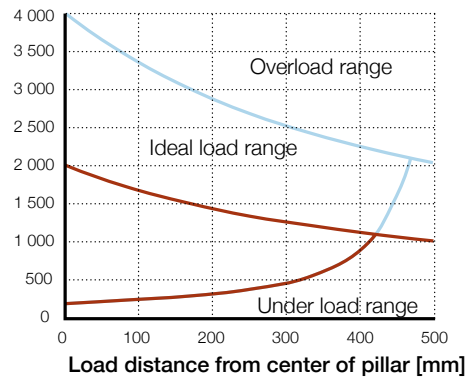

— TLT1 A-2 — TLT1 C-2

Accessories

	Designation	Order number
Top mounting plate	ZPL-290268	0125624
Bottom mounting plate	ZPL-290265	0125623
Screw (4/plate) for mounting plate	ZBE-510707	0125360

Ordering key

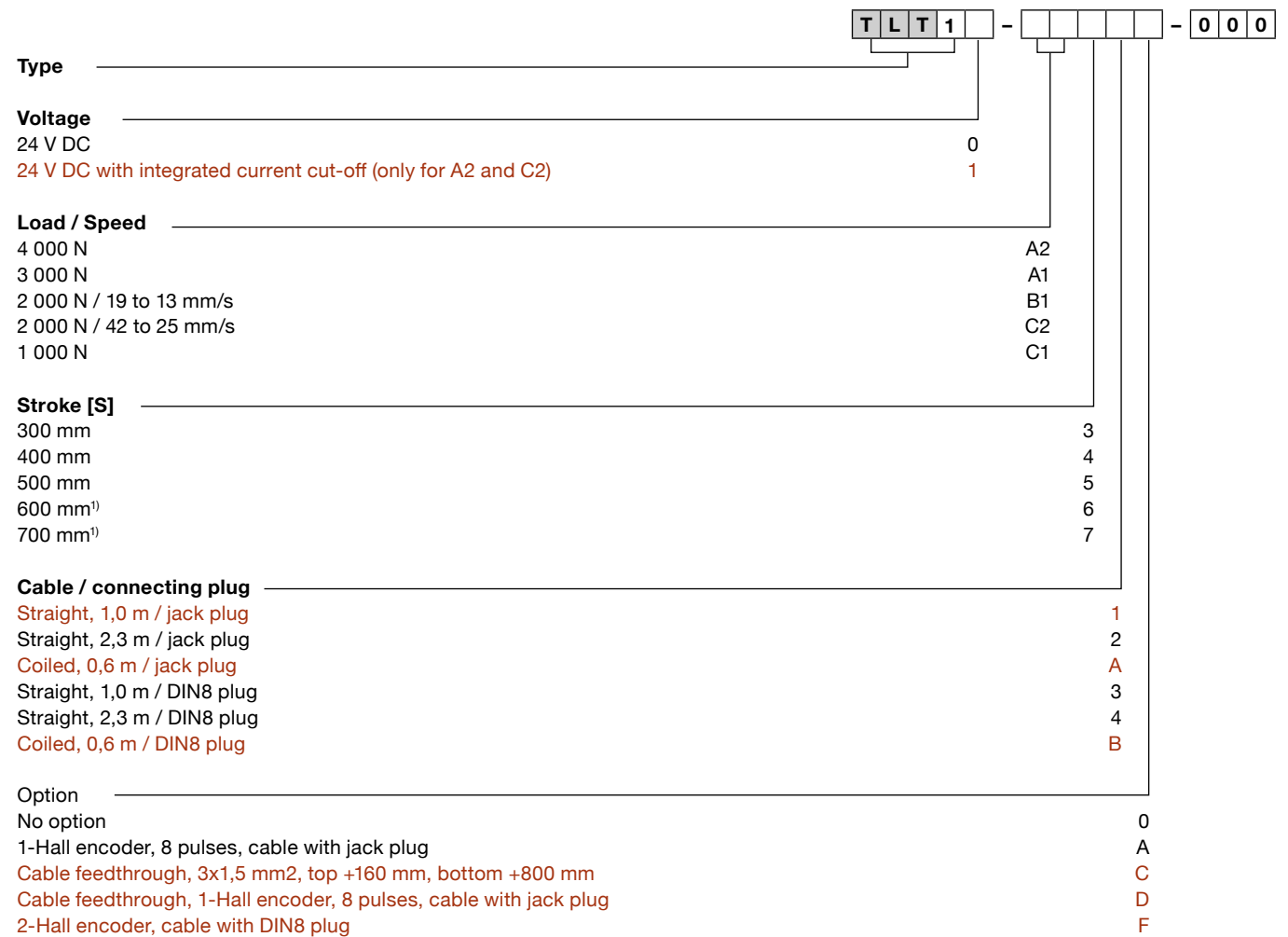

¹⁾ Reduced safety factor

Options written in yellow are only available on demand. Contact Ewellix for more information on minimum quantities and additional costs.

TLT20

Telemag telescopic pillar

Benefits

- Very small built-in dimension
- Powerful
- High speed

Standards

- EN/IEC 60601-1
- UL 60601-1



Technical data

	Unit	TLT20-A3
Rated push load	N	5 000
Rated pull load	N	0
Bending load	Nm	up to 500 ¹⁾
Speed (full load to no load)	mm/s	18 to 28
Telescopic pillar version	# of section	3-section
Stroke	mm	300 to 700
Retracted length	mm	0,5 × S+130
Voltage	V DC	24
Power	W	312
Current	A	2×6,5
Duty cycle: intermittent operation	min.	1 min./9 min
Ambient temperature	°C	+10 to +40
Type of protection	IP	00
Protection class	–	SELV
Type of control	–	electrical
Weight	kg	15 to 30

¹⁾ For details, please see bending load diagrams (↳ page 4)

Dimensional drawing

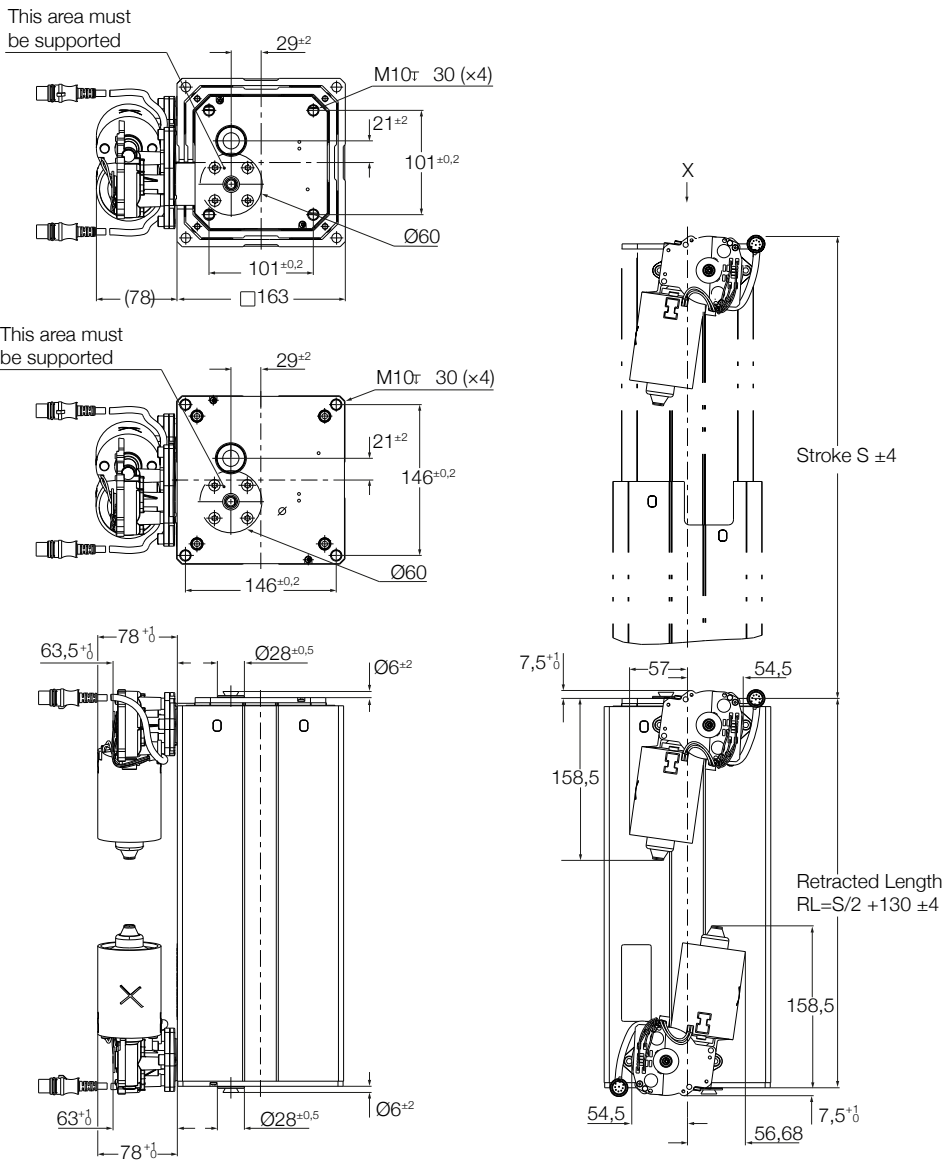

Note: mounting plates are not included. To be ordered separately.

Legend:
 S = stroke
 L = retracted length

Connecting diagrams

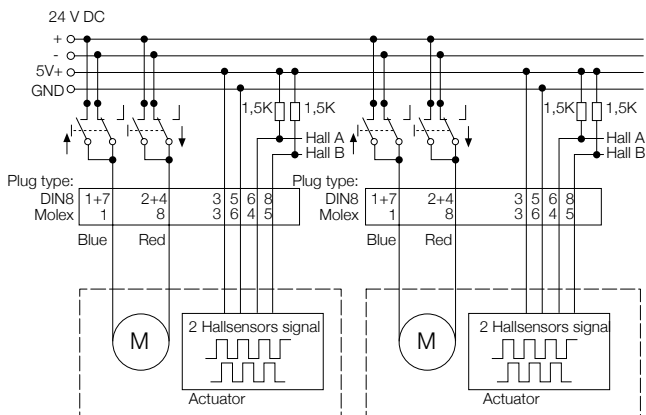

Suitable control units and accessories

		Control unit							
		SCU 1	SCU 5	SCU 9	VCU 5	VCU 8	VCU 9	BCU 5	BCU 8
TLT		•	•	•	•	•	•	•	•
Operating switches									
EHA 3		•	•	•	•	•	•	•	•
STJ		•	•	•	•	•	•	•	•
STE		•	•	•	•	•	•	•	•
		Hand switch	Foot switch			Desk switch			

Performance diagrams

Speed-load diagram

Speed [mm/s]

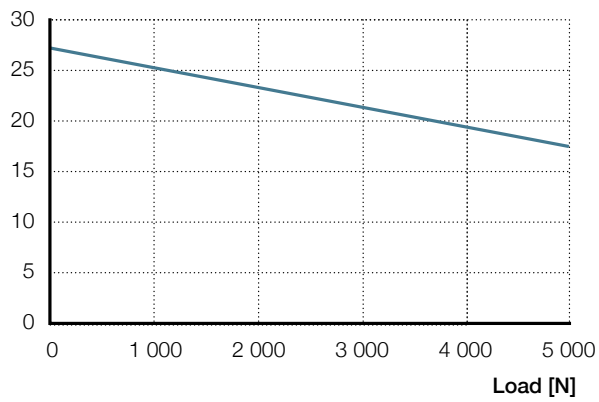

Current-load diagram

Current consumption [A]

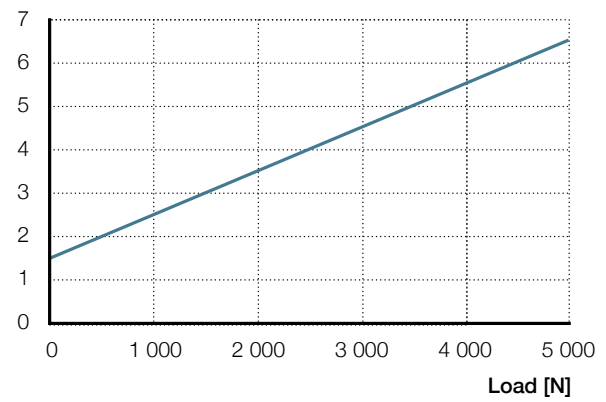

Bending load diagrams

Bending load diagram

Load [N]

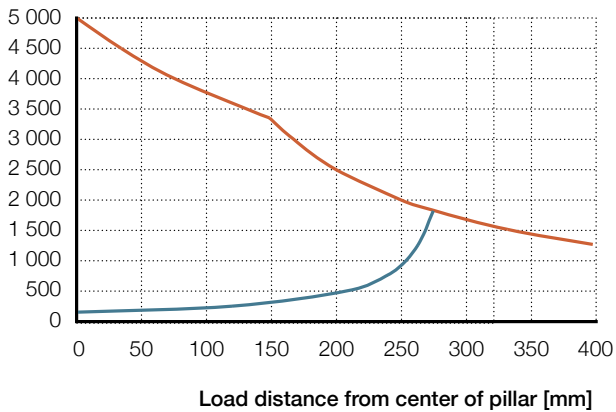

Ordering key

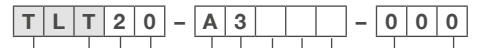

Type _____
Voltage _____
 20 24 V DC with 2 external motors

Load / Speed _____
 A3 5 000 N / 20 mm/s

Stroke [S] _____
 3 300 mm
 4 400 mm
 5 500 mm
 6 600 mm¹⁾
 7 700 mm¹⁾
 X Other (on request only)

Cable / connecting plug _____
 D Cable straight with DIN8, length 1 000 mm
 M Cable straight with Molex Mini-Fit Jr. 8-pin, length 50 mm

Option _____
 0 No option
 F 2-Hall encoder

7 Customer option _____
 Consecutive number (provided by Ewellix)

¹⁾ Reduced safety factor

Options shown in red are only available on demand. Please contact Ewellix for more information on minimum quantities and additional cost.



ewellix.com

© Ewellix

All contents of this publication are the property of Ewellix, and may not be reproduced or given to third parties (even extracts) without permission. Although great care has been taken in the production of this catalog, Ewellix does not take any responsibility for damage or other loss resulting from omissions or typographical errors. The photo may differ slightly in appearance from the actual product. Due to continuous improvements being made in our products, the product's appearance and specifications are subject to change without notice.

PUB NUM TC-08023-EN-May 2020