

EWELLIX

MAKERS IN MOTION

INSTALLATION, OPERATION AND
MAINTENANCE MANUAL

Control unit - VCU



1

Introduction

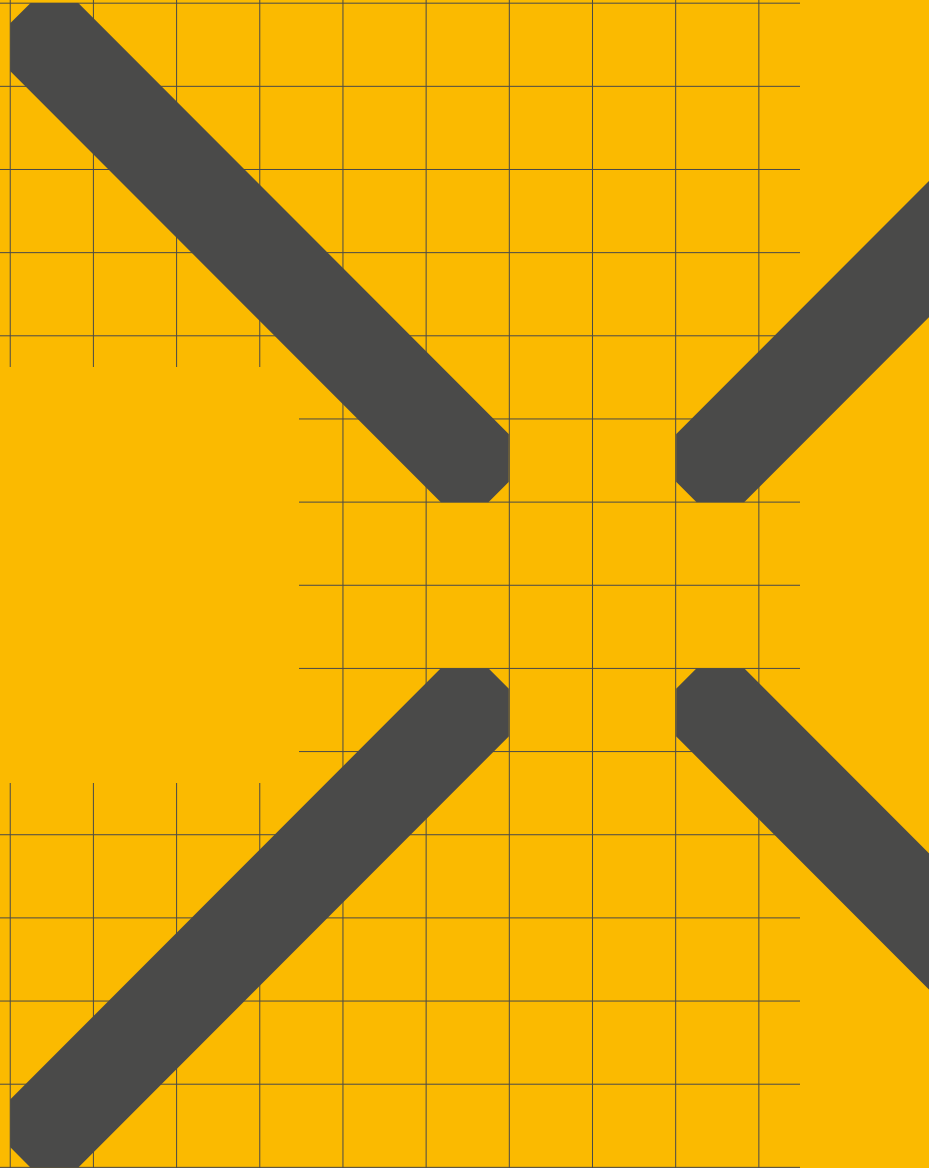

Contents

1.0 General information.....	4	6.0 Maintenance.....	16
1.1 Information on this manual.....	4	6.1 Malfunctions.....	16
1.2 Explanation of symbols and signal words.....	4	6.1.1 Fault rectification.....	17
1.3 Operation manual.....	4	6.2 Repair.....	18
1.4 Organizational measures.....	5		
2.0 Safety.....	6	7.0 Removing from service, dismantling and disposal	18
2.1 Safety program.....	6	7.1 Shutting down.....	18
2.1.1 Purpose of use of the VCU control unit.....	6	7.2 Dismantling.....	18
2.1.2 Intended Use.....	6	7.3 Storage.....	18
2.1.3 Unauthorized use.....	6	7.4 Disposal.....	19
2.1.4 User groups.....	6		
2.1.5 Types of operation.....	7	8.0 Appendix.....	19
2.1.6 Danger zones.....	7		
2.1.7 Areas of responsibility.....	7		
2.1.8 General safety notice.....	7		
2.2 Other hazards.....	7		
3.0 Construction and function.....	8		
3.1 Construction.....	8		
3.2 Function.....	9		
3.2.1 Functional principles.....	9		
3.3 Options and accessories.....	10		
4.0 Normal operation.....	10		
4.1 Preconditions for operation.....	10		
4.2 VCU control unit powering on.....	12		
4.3 VCU control unit shutting down.....	12		
5.0 Special operations.....	12		
5.1 Preparation.....	12		
5.2 Installation and connections.....	14		
5.3 Initial Start-Up.....	16		

WARNING

Read this manual before installing, operating or maintaining this actuator. Failure to follow safety precautions and instructions could cause actuator failure and result in serious injury, death or property damage.

1.0 General information

1.1 Information on this manual

This manual provides information necessary for the proper and safe installation, operation, maintenance, dismantling and disposal of this column (also called device). It is an integral part of the equipment, and must be kept so that it is accessible to personnel.

Before doing anything with this device, personnel must read this manual thoroughly and understand its contents.

Compliance with all specified safety instructions and operating instructions is vital for safe and proper use of this device.

In addition, national and local governmental accident prevention regulations and general safety instructions must be observed in the area where this device is being used.

Illustrations in this manual are intended to facilitate a basic understanding of these concepts and may differ from the actual design.

1.2 Explanation of symbols and signal words

Safety precautions

Safety precautions in this manual are identified by symbols and signal words. These signal words (shown to the right) indicate the severity of the hazard.

Adhere to these safety precautions and act cautiously in order to avoid accidents resulting in personal injuries and damage to the device and the equipment into which it has been installed.

DANGER

Indicates a dangerous situation, which will lead to death or serious personal injury, if the precautionary measures are ignored.

WARNING

Indicates a dangerous situation, which can lead to minor or moderate injury or property damage, if the precautionary measures are ignored.

CAUTION

Indicates a dangerous situation, which can lead to minor or moderate injury, if the precautionary measures are ignored.

NOTICE

Indicates information considered important, but not hazard-related (e.g. messages relating to property damage).



NOTE

Emphasizes useful hints and recommendations as well as information for efficient and trouble-free operation.

1.3 Operation manual

Ewellix manufactures state-of-the-art electric actuators, control units and operating devices.

The purpose of this operation manual is to introduce you, as the user and the entity doing the further processing, to correct utilization and safe use.

For this goal to be achieved, it is essential that you very carefully read the chapter on safety (↳ **2. Safety, page 6**) and follow the instructions in this manual.

Validity

The instructions in this manual refer to the VCU control unit with the following identification:

- Manufacturer: Ewellix
- Product name: VCU control unit
- Type designation: VCUxx-xxxxxx-xxxx
- Year of manufacture: from 2005
- CE Mark: according to technical documentation
- Serial number: from L04040000

Target audience and obligation to read

The operating manual is intended for technical personnel and authorized users who use the VCU control unit in their products and work with them. The operating authority determines who is authorized as a user.

We distinguish between different user groups, as the requirements on the users vary, depending on the activity they perform.



NOTE

Please note: You can find definitions of user groups along with their corresponding requirements in the chapter on safety (↳ **2. Safety, page 6**). You can assume one or more of these user groups provided you meet the applicable requirements.

The organization and implementation of the operation manual takes into account the different user groups.

Summary of contents

The operation manual serves as a reference work. The information therein is organized into four task- and theme-related parts:

The **Basic Principles** section gives the basic knowledge that every user should have.

The **Normal Operation** section contains information needed for operating the product under normal conditions, i.e. uninterrupted operation for use according to its intended application.

The **Special Operations** section describes all jobs deviating from normal operation, such as installation, initial start-up, maintenance, fixing faults and doing repairs.

The **Appendix** contains information that the user has to be able to access at any time. This includes information on using the operation manual (indexes) as well as data concerning the product itself (technical data).

Aids for accessing information

This manual has access aids that make it easier for you to quickly access the desired information:

- You can most easily find all information on a given topic in the Table of Contents, as a result of the task and theme-related organization of the operation manual.
- Information on a specific activity or a special topic can be found most quickly through the Index.
- Within the chapters of the operation manual, you can orient yourself with the help of the margin notes.

1.4 Organizational measures

If you have any questions that cannot be answered through this operation manual, contact the manufacturer directly.

Location of the operation manual

The operation manual can only benefit you if you have it available at all times. For this reason, always keep the operation manual where the equipment is being used.

Manufacturer address Ewellix

Oristalstrasse 97
 CH-4410 Liestal
 Tel.: +41 / 61 / 925 41 11
 Fax: +41 / 61 / 921 37 04
 E-mail: actuators.switzerland@Ewellix.com

Contact address

Your local Ewellix representative.

2.0 Safety

This chapter targets all the users of the VCU control unit. It contains information on its safe use and optimal utilization.

2.1 Safety program

The safety program from Ewellix spells out who is entitled to use it and the responsibility of individual users.

The VCU control unit was designed and built in accordance with the latest technical standards and accepted safety rules.

EU-conformity is documented with the technical documentation.

2.1.1 Purpose of use of the VCU control unit

The VCU control unit has been designed and constructed for use in accordance with its intended purpose-conformant use. If you use the VCU control unit for any use other than the use described, the manufacturer cannot be held liable for damage that results therefrom.



NOTE

Please note: The control can only be parametrized for the drives of Ewellix. Please contact customer services to find out which drives are approved for the VCU control unit (refer to [Manufacturer Address, page 5](#)).

2.1.2 Intended Use

The authorized use of the VCU control unit is to:

- Control a maximum of five actuators for pressure or tension stressed strokes.



NOTE

Please note: For the operations data, please see the Appendix of this operating manual ([VCU, page 21](#)).

2.1.3 Unauthorized use

Any use other than the intended use without the manufacturer's written agreement or operation beyond the technical limits is considered unauthorized.

The technical usage limits can be found in the appendix to this operation manual see [page 22](#) and on the type plate of the VCU control unit.



NOTE

Please note: in case of improper use of the VCU control unit, damage to persons and property may result. Always adhere to the instructions of this manual.

2.1.4 User groups

To ensure safety, we place requirements on the users of the VCU control unit that must be adhered to under all circumstances. Only persons who meet the requirements are entitled to use the VCU control unit.

We refer to all persons who operate, use, commission the control unit, process it further or pass it on for further processing as user groups. As the requirements of these user groups strongly depend on their role, we distinguish between the following user groups:

The **operating authority** is the contractual partner of the person doing the further processing or the reseller. They can impose legal conditions on the operating authority when purchasing the control unit. The operating authority ensures that the user is instructed in the authorized use of the equipment.

The **processor** is the contractual partner of the reseller or the manufacturer. He assembles the control unit into a total device. He is authorized by the manufacturer of the VCU control unit to use the control unit in accordance with the regulations and has the necessary expert knowledge.

The **technician** has the professional technical training to implement the VCU control unit according to its authorized use. Apart from the chapter on Safety, he is also familiar with the chapter on Special operating modes. He will find the required technical data in the Appendix.

The **reseller** forwards the machine.

Every other person who uses the VCU control unit we define as an **operator**. The operator must have read the Safety chapter in this manual before using the machine. Moreover, he must be instructed about the normal operation by the operating authority.

2.1.5 Types of operation

The VCU control unit is exclusively intended for **intermittent** operation (↳ **Technical data, page 22**).

2.1.6 Danger zones

We differentiate between two danger zones that must be observed, depending on user role.

The danger zone covering persons also includes, in addition to the actual user, third **persons** (other personnel, visitors, patients etc.). In case of injury, the operating authority is liable.

The danger zone device comes under the user group Executor and Technician and covers the VCU control unit and all the mounted-on **devices**.

2.1.7 Areas of responsibility

Different areas of responsibility, corresponding to the different user groups, arise.

The **Operating Authority** has the responsibility for the danger zone covering Persons and ensures that only authorized and instructed users work with the VCU control unit. He or she is responsible for the following:

- Determining the persons who may use the VCU control unit (authorized persons)
- Instruction of the users
- Complying with all relevant legal conditions and regulations



NOTE

Please note: The Operating Authority may only authorize such persons for using the VCU control unit, who conform to the requirements for the user roles.

The **processor** is responsible for the following:

- Generation of a CE-conformant operation manual of the device in which the VCU control unit has been integrated
- Adherence to the safety regulations in accordance with this operating manual

The **reseller** is responsible for the following:

- Passing on this operating manual and the VCU control unit to the executor or the
- Passing on of a CE-conformant operating manual and the device in which the VCU control unit has been integrated to the Operating Authority.

The **technician** is responsible for the following:

- Observing the manufacturer's instructions and the safe set-up of interfaces with other equipment.
- Installation and use of the VCU control unit in accordance with its intended purpose-conformant use
- Installation of optional modules and connecting cables

The **operator** ensures that nobody is endangered owing to the operation of the VCU control unit. He or she is, in particular, responsible for:

- Operation of the VCU control unit in normal operation
- Immediate and appropriate reaction to malfunctions

2.1.8 General safety notice

The VCU control unit is only suitable for interior applications and must not be subjected to weathering, strong UV radiation or corrosive or explosive air (see Ambient conditions, ↳ **Technical data, page 22**).

The VCU control unit may only be operated with the safety protective cover closed.

2.2 Other hazards

The manufacturer has constructively, and with protective measures, minimized the effects of existing residual hazards. Pay attention to the residual hazards and the potential countermeasures given in the following chapters.

Residual hazards to people, objects and property

Keep in mind the following residual dangers and the possible countermeasures in handling the VCU control unit:

WARNING

Warning regarding electrical shock owing to damaged plugs or damaged network cables. Never touch a damaged network plug or a damaged network cable when the VCU control unit is running, since the VCU control unit are supplied 120 V AC or 230 V AC.

- Ensure, before you pull a defective plug out of the plug socket, that the current fuse is cut off.
- Check the power cable regularly for damage.

CAUTION

Take care not to damage the VCU control unit from waterjets. The VCU control unit is protected against spraying water according to IPX4, but not against water jets. Prevent the VCU control unit from being subjected to water jets.

CAUTION

Please be aware of damage to people or property as the result of incorrect operation. Incorrect operation can endanger people in the danger zone or objects.

- Before pressing a button on the operating unit ensure that you press the right button.
- Take appropriate measures to ensure that the operating unit can not be operated unintentionally.

3.0 Construction and function

This chapter targets all the users of the VCU control unit. It shows its construction and explains its function.

3.1 Construction

The following figures will give you an overview of the VCU control unit, its connections and operating devices.

Overall view and connections VCU control unit

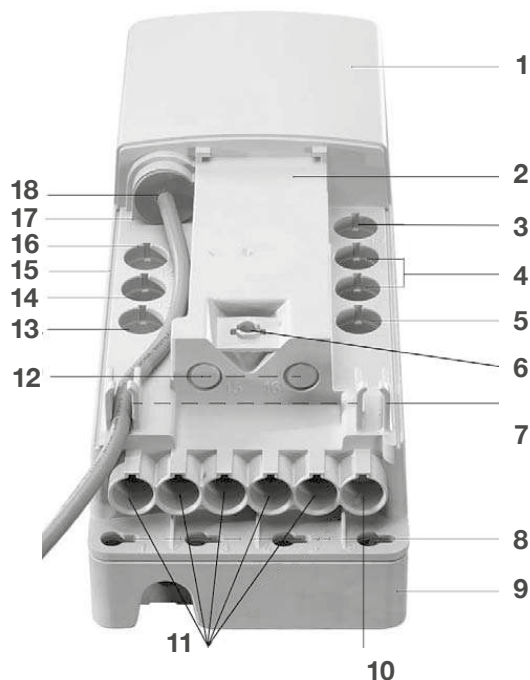
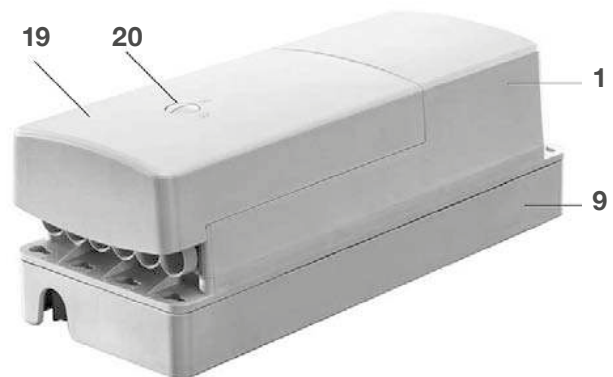

Fig. 3-1 Overall view VCU control unit from above with under-floor rechargeable battery, without safety protective cover (in image: DC design with connection cable)

1. Housing
2. Space for software data label
3. not occupied (socket 10)
4. Connection for operating elements (sockets 8, 9)
5. Connection for 2 external end switches (socket 7)
6. Fastening for safety protective cover
7. Cable guides
8. Installation holes (4)
9. Under-floor rechargeable battery
10. not occupied (socket 6)
11. Connection for actuators / columns (sockets 1 to 5)
12. not occupied (sockets 15, 16)
13. not occupied (socket 14)

14. Optional rechargeable battery connection (socket 13)
15. Operational voltage indicator (not visible on this image)
16. not occupied (socket 12)



17. Operational earthing bolt (not visible on this image)
18. Mains connection or connection for source of DC voltage (socket 11)
19. Safety protective cover
20. Locking button for safety protective cover

Fig. 3-2 Side view with under-floor rechargeable battery and closed safety protective cover

Operating elements

Following operating elements are suitable for the VCU control unit:

- EHA 3, manual switch
- STJ, foot switch
- STE, table switch

3.1 Function

The description of the function will make it possible for you to understand the tasks of the VCU control unit, its operating devices and its options.

NOTE

Please note: Please note that the functions, plug layouts and options of the control unit are configured ex-works according to the requirements and cannot be changed subsequently.

3.1.1 Functional principles

The principle of functioning of the VCU control unit is based on controlling a maximum of five connected actuator units. The functions present in the control program are actuated by means of manual switches or other operating devices. The VCU control unit is configured by the manufacturer.

The VCU control unit must be equipped with one operating device and at least one actuator unit. The DC design requires a source of DC voltage.

The **operating voltage indicator** (↳ **position 13, Fig. 3-1, page 9**) indicates whether the device is being supplied energy.

In the standard configuration the VCU control unit is **fail-safe**. Here the device checks **safety**-relevant electronic system parts and if a defect occurs moves to the safe status in which no actuator movements are possible until the defect has been removed (↳ **6.1 Malfunctions, page 17**). The maximum error tolerance period is one second.



NOTE

Please note: If a connected actuator does not have an internal end switch or an internal thermo-switch this reduces the system's failsafe system. Actuators without internal end switches are switched off with over-current. If an actuator does not have an internal thermo-switch and there is a defect, the actuator could overheat and be damaged.



NOTE

Please note: The system's failsafe mechanism is reduced if an operating unit without failsafe is connected.

Only for DC design: A smoothed power unit can be used as a **DC voltage source**. But it must be noted that during operation (actuator is moving) the nominal voltage permitted for the drives may not be exceeded (please note the other details in the annex). (↳ **Device Data, page 22**).

The **safety protective cover** protects the cable connections from being pulled out accidentally.

The VCU control unit has a **lock function**. When using an appropriate operating unit with corresponding functional buttons it is possible to lock or release individual control unit functions. The signal is passed on to the control unit - the lock function of the VCU control unit takes on the locking or unlocking function. This ensures that there is no risk from several operating devices used at the same time. If necessary locked functions are indicated by a yellow LED.

The software with its integrated **over-current cutoff** switches off the VCU control unit in case of overload and protects the connected actuator units. The factory must parameterize the appropriate power-down values for the connected actuator.

3.2 Options and accessories

Options

Options can be recognized from the type designation on the type plate.

The VCU control unit may be fitted with a **battery connection** (↳ **item 14, Fig. 3-1, page 9**) or a pre-installed under-floor battery. The unused battery connection is equipped with a sealing stopper by the factory. Rechargeable batteries are available as accessories (↳ **Accessories, page 11**).



NOTE

Please note: without an external battery the connection socket must be equipped with the factory-supplied sealing stopper for IPX4 protection to be guaranteed. Please note the special requirements for handling rechargeable batteries. Only batteries authorized by the manufacturer may be used.

The connection for the **end switch** is available for all versions of the VCU control unit. But this option must be set by the manufacturer in the factory. Here the end switches can take on various functions. The connection socket is equipped with a sealing stopper by the factory.



NOTE

Please note: without an end switch the connection socket must be equipped with the factory-supplied sealing stopper for IPX4 protection to be guaranteed.

Protection class I; three-core mains supply cable with **ground terminal** on the housing (↳ **position 17, Fig. 3-1, page 9**). Marked with the following signal:

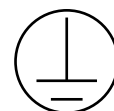

Accessories

The authorized batteries¹⁾ or under-floor **batteries** are screwed to the underside of the VCU control unit. The VCU control unit can only be operated with a battery if the corresponding option has been selected (↳ **3.3 Options and accessories, page 10**).

In addition to the hand switch other operating units are available as accessories on request from a reseller. The operating units create a function in the control unit. The function depends on the type of control unit (parameterization) and usually allows the actuator to move in or out.

The **operating units** are not contained in the supply schedule and must be ordered separately. Only operating units that have been authorized for the VCU control unit can be used²⁾.

Order the **mains cable** with the plugs that are correct for your country and the appropriate protective class for your unit. In order to guarantee the protective class of the VCU control unit it is only permitted to use original Magnetic mains cables with the label ZKA- 160xxx-xxxx.

The connection cable is provided for the DC version.

¹⁾ Authorized batteries can be ordered from the reseller.

²⁾ If the VCU is to be operated by a super-ordinate control unit, the control unit must be configured as appropriate. Please refer to the manufacturer on this matter.

4.0 Normal operation

This chapter is directed at the user groups operator and operating authority. It contains all the information that is required for the safe and problem-free use of the VCU control unit in normal operation.

In normal operation the VCU control unit analyses signals from one operating device in order to actuate the printing or stroke movements with the appropriate actuator.

4.1 Preconditions for operation

The VCU control unit controls one to five actuator units. The safety protective cover must be closed and the power supply ensured (energy supply lamp glows). The optional **rechargeable battery** facilitates **operation** without connection to the power supply (↳ **3.3 Options and accessories, page 10**).

The rechargeable must be adequately charged for operation using it. The following table gives you an overview:

Tab. 4-1 Status of the rechargeable battery in various operating modes with the corresponding LED indicator.

Operating mode	LED indicator	To be carried out by
Control powered by mains or DC feed	Lights up green	full
Control fed separately from mains via rechargeable battery	Flashes green.	charging mode
	Lights green when you press a button on the operating unit	full
	Lights orange when you press a button on the operating unit; an acoustic signal also sounds.	weak, a full stroke with an actuator drive is still possible (approx. 2 minutes)
	Flashes orange when you press a button on the operating unit; an acoustic signal also rings	very weak, only one movement in counter-load direction possible

Check the following points and ensure that

- no cable is squashed during operation
- installation is completed correctly
- all operating units are in the proper locations
- no people are located in the danger zone

4.2 VCU control unit powering on

⚠ WARNING

Warning regarding electrical shock owing to damaged plugs or damaged network cables. Never touch a damaged power plug or a damaged power or mains cable when the VCU control unit is running, since the VCU control unit are supplied 120 V AC or 230 V AC.

- Ensure, before you pull a defective plug out of the plug socket, that the current fuse is cut off.
- Check the power cable regularly for damage.

⚠ CAUTION

Please be aware of damage to people or property as the result of incorrect operation. Incorrect operation can endanger people in the danger zone or objects.

- Before pressing a button on the operating unit ensure that you press the right button.
- Take appropriate measures to ensure that the operating unit can not be operated unintentionally.

The preconditions for operation must be fulfilled (↳ **4.1 Preconditions for operation, page 12**). Operation takes place using an operating device (↳ **3.3 Options and Accessories, page 10**).

📄 NOTE

Please note: You can move the actuator units in and out by pressing the appropriate button on the operating unit. If the movement does not stop as soon as you release the button you must press the button for the opposite direction immediately to stop it.

📄 NOTE

Please note: The connection to the operating unit (5 V DC) and the actuator unit (24 V DC) is made via safety low voltage.

4.3 VCU control unit shutting down

Shut the VCU control unit down by pulling the plug of the control unit from the power socket.

5.0 Special operations

The following chapters are part of the special operations:

- **5.2 Installation and connections, page 14**
- **5.3 Initial Start-Up, page 16**
- **6. Maintenance, Clearing Malfunctions, Repairs, page 17**
- **7. Removing from service, dismantling and disposal, page 20**

Installation and initial start-up

This chapter is intended for technicians and those doing the further processing. It contains all the information that is required for the erection, connection and commissioning of the VCU control unit.

5.1 Preparation

Good preparation is part of efficient installation and start-up. This includes, among other things, clarifications regarding the locations and the preparation of the energy supply.

Transport



NOTE

Please note: The control unit must be examined for cracks in the housing when it is delivered. Immediately report any transportation damage that is found in writing to the freight-forwarding company and the manufacturer (↳ **1.4 Manufacturer Address, page 5**).

The VCU control unit is delivered packed as one unit in a cardboard box or in palettes.

Entrust a freight forwarder with the dispatch of the VCU control unit.

Prepare the VCU control unit for transport as follows:

21. Dismantle the VCU control unit (↳ **7.2 Dismantling, page 20**).

22. Pack the VCU control unit carefully.



NOTE

Please note: You will find weight, dimensions and the environmental requirements in the technical data in the appendix (↳ **Technical Data, page 22**).

Check the supply schedule

The VCU control unit consists of:

- a complete control unit
 - with safety protective cover
 - DC design with connection cable

- 2 sealing stoppers (pre-assembled by factory; Art. ZDV-160307-0008)
- 2 or 3 (with optional rechargeable battery connection) sealing stoppers (preassembled by factory; Art. ZDV-160308-0015)
- optional 1 under-floor rechargeable battery

Power supply

The VCU control unit only requires electrical energy for operation. Observe the connection values in the appendix of this manual (↳ **Device Data, page 22**).

5.1 Installation and connections

The mounting and alignment of the VCU control unit, as well as the interfaces and connections are shown in the following sections.

Mounting and alignment

The following points must be kept in mind as regards the mounting and alignment of the VCU control unit.

Make sure that

- the mains plug of the connection cable remains accessible at all times,
- the mains, DC and rechargeable battery cables can not be bent or squashed.
- the connecting cables to the actuators cannot get crushed or squashed.
- the VCU control unit is set up on a level surface (if the casing is bent during setup the IP protection is no longer guaranteed)
- the VCU control unit is set up properly and can not loosen itself through impacts and vibrations.

Interfaces and Connections

⚠ CAUTION

Warning regarding damage to the control unit owing to tilted plugs or damaged cables. Ensure that the plugs remain freely accessible and all cables remain safe and hidden.

You can find the nominal values in appendix (↳ **Technical Data, page 22**). Check the following interfaces and connections and carry out the following processes:

23. Carry out the connect the operating device(s), **page 15** process.
24. Carry out the connect the actuator unit(s), **page 15** process.
25. Carry out the connect the mains cable to the control unit, **page 15** process.
26. Optional: carry out the connect end switches, **page 15** process.
27. Optional: carry out the connect rechargeable battery, **page 15** process.
28. Carry out the mount the safety protective cover, **page 16** process.
29. Follow the warnings on the type plate.
30. Protection class I unit: carry out the connect ground wire, **page 16** process.
31. a For AC design: Insert the mains cable plug into the mains plug.
b For DC design: Close the stranded wires of the DC cable to a suitable voltage source (DC feed must be protected against short-circuiting etc.).

Process: Connect the operating device(s)

1. Connect the HD15 plug of the operating device carefully and in the correct position to the corresponding socket of the VCU control unit (↳ **item 4 in Fig. 3-1, page 9**).
2. Check that you have used the correct connection socket.
3. *Repeat step 1 if necessary for a second operating unit.

Comment: Please note the additional instructions in section **Accessories, page 11**. The IPX4 protection is only guaranteed if the connecting sockets not being used are closed with a sealing stopper.

Process: Connect the actuator unit(s)

Requirements: Only actuators that have been approved by the manufacturer may be connected. Contact customer service (↳ **Manufacturer Address, page 5**) to ensure that the actuator unit used for this control unit is permitted.

1. **Plug in the plug of the actuator in the corresponding connecting socket of the VCU control unit (↳ Figure Fig. 3-1, page 9).**
2. **Check whether the letter on the label clip on the actuator matches the letter on the data label (↳ position 2 of Fig. 3-1, page 9) of the corresponding socket.**



NOTE

Please note: Incorrectly inserted drives can be damaged.



NOTE

Important: Depending on the number of actuators that you operate with the VCU control unit, they must be connected in the following manner:

- 1 Actuator unit: connection socket 1
- 2 Actuator units: connection sockets n 1 and 2
- 3 Actuator units: connection sockets 1 to 3
- 4 Actuator units: connection sockets 1 to 4
- 5 Actuator units: connection sockets 1 to 5



NOTE

Note: The IPX4 protection is only guaranteed if the connecting sockets not being used are closed with a sealing stopper. Two sealing stoppers are part of the supply schedule.

Process: Connect the mains cable to the control unit

Requirements: see **Technical Data, page 23** chapter for the permitted values.

1. Insert the country-specific mains cable (↳ **Accessories, page 11**) in the correct direction in the corresponding connection socket of the VCU control unit.

Process: Connect end switches

Requirements: The corresponding option must be factory. Remove the sealing stoppers.

Tools: To ensure safe operation only use forced-open contacts. Closing contacts are required to provide movement.

1. Plug in the plug of the actuator in the corresponding connecting socket of the VCU control unit.



NOTE

Please note: A diagram of the end switch connection is found in the appendix (↳ **Plans and diagrams, page 22**).



NOTE

Please note: A diode is required to check the line to the end switches (initial defect safety). If parameterized appropriately 24 V DC signals (e.g. SPS) can be processed by the VCU control unit.

Process: Connect rechargeable battery

Requirements: Optional rechargeable battery connection must be available (↳ **Options, page 10**). Remove the relevant sealing stoppers.

1. Fix the rechargeable battery to the control unit.
 - 1.1. **a** Under-floor rechargeable battery: Screw the under-floor rechargeable battery to the underside of the VCU control unit.
 - 1.2. **b** Other permitted rechargeable battery packages: Screw the rechargeable batteries in the right direction to a suitable location.

2. Check the plug of the rechargeable battery for damage.

**NOTE**

Please note: Bent plug pins could result in a short circuit and damage the battery.

3. Plug in the battery plug in the corresponding connecting socket of the VCU control unit.

Process: Mount the safety protective cover

Requirements: All plugs required are connected and all unused connections blocked with sealing stoppers.

1. Plug the safety protective cover to the rear side of the device VCU control unit till the fastening of the safety protective cover meshes.

**NOTE**

Please note: If it is not possible to place the safety protection cover properly the plugs may not be inserted properly.

**NOTE**

Please note: You can remove the safety protective cover only with a tool (↳ **7.1 Shutting down, page 20**).

Process: Connect ground wire

Requirements: Only for units with protective class I

1. Connect the cable shoe to the earth connection using the nut from the ground wire screw.

**NOTE**

Important: The ground wire must be firmly connected with an adequately small contact resistance that should under no circumstances come loose.

**NOTE**

Important: The nut may not be tightened too much because this could cause damage to the housing and the IPX4 protection could no longer be guaranteed. The 1-2 Nm torque should not be exceeded.

Installation**WARNING**

Warning regarding electrical shock owing to damaged plugs or damaged network cables. Never touch a damaged network plug or a damaged network cable when the VCU control unit is running, since the VCU control unit is supplied with 120 V AC or 230 V AC. Ensure, before you pull a defective plug out of the plug socket, that the current fuse is cut off.

The VCU control unit must be screwed with the application. Fix the control unit such that the minimum of four fixing screws required can not loosen and slip through the screw holes.

5.1 Initial Start-Up

Before you make the VCU control unit operational, carry out the installation inspection.

Installation inspection

Check the following points before the initial start-up:

- Operating device connected (↳ **Connect the operating device(s), page 15**)
- Actuator unit connected (↳ **Connect the actuator unit(s), page 15**)
- Connect the mains cable to the control unit (↳ **Connect the mains cable to the control unit, page 15**)
- Optional: end switches connected (↳ **Connect end switches, page 15**)
- Unused connecting plugs closed with stopper plugs (↳ **Connect the actuator unit(s), page 15**)
- Safety protective cover installed (↳ **Mount the safety protective cover, page 16**)
- For AC design: Energy supply to mains plug guaranteed
- For AC design: Mains cable connected
- For DC design: DC cable connected to appropriate DC voltage source
- Free access to the mains plug ensured
- Operating voltage indicator lights up

**NOTE**

Please note: Ensure that all unoccupied connection sockets that are not equipped with an appropriate plug have a sealing stopper. Otherwise IPX4 protection can not be guaranteed.

Commissioning

After the installation inspection, you must carry out a comprehensive function check.

**NOTE**

Please note: Ensure that the plugs for the operating units and the end switches are identical. Ensure they are working properly by undertaking the function check.

Then you can commission the VCU control unit. To do so, press the corresponding actuation button of the operating device.

6.0 Maintenance

The maintenance includes all the work that serves for the upkeep of the functional VCU control unit. These operations include inspections, replacing consumables and cleaning.

Maintenance plan

The VCU control unit (excluding rechargeable battery) is maintenance-free during its entire life (the life is specified in the annex, [↪ Technical data, page 22](#)). The connection cable, control, casing and operating unit must be checked for damage regularly.



NOTE

Please note: damaged casing does not provide IP protection. Damaged cables could result in a short circuit.

The VCU with **rechargeable battery** must be connected to the mains or a source of DC voltage periodically for 12 hours in order to protect the battery from full discharging and therefore from destruction (this applies after 6 weeks for pre-assembled under-floor batteries with 2.7 Ah).

Cleaning and disinfection

⚠ CAUTION

Take care not to damage the VCU control unit from water jets. The VCU control unit is protected against spraying water according to IPX4, but not against water jets. Prevent the VCU control unit from being subjected to water jets.

Observe the following points when cleaning and disinfecting:

- Wash water including added chemicals must be pH-neutral.
- Acidic or alkaline wash water can destroy metallic and synthetic parts.
- Handwash disinfection exclusively with isopropyl alcohol



NOTE

Please note: Any cleaners other than those mentioned will damage the VCU control unit.

6.1 Malfunctions

Malfunctions to the VCU control unit may only be resolved by the manufacturer. For this purpose, the VCU control unit must be shut down and sent to the Ewellix Actuation System ([↪ section Transport, page 14](#)).

In the following sections, you will find hints on how you can recognize, remedy or handle malfunctions.



NOTE

Please note: In any case, immediately inform customer service ([↪ Manufacturer Address, page 5](#)) if the fault cannot be rectified on the basis of the following instructions.

6.1.1 Fault rectification

1 – Actuator does not move any more.

Hypothesis 1-A

No supply voltage, or wrong supply voltage, or missing plug contact or supply indicator lamp does not glow.

2. Check the operating voltage specification on the type plate and check whether the mains voltage of the socket corresponds to this value.
3. Check the mains plug of the VCU control unit and insert it if required into a mains socket.
4. Check the supply voltage and if required, change the fuse.
5. Check the HD15-plug of the operating device and if required, insert it into the VCU control unit ([↪ Process Connect the actuator unit\(s\), page 15](#)).
6. Check the DIN8 plug of the actuator and if required, insert it into the VCU control unit ([↪ Process Connect the actuator unit\(s\), page 15](#)).

Are the supply voltage and the plug contacts intact?

Yes: **4. Normal Operation, page 12**

No: **Hypothesis 1-B**

Hypothesis 1-B

VCU control unit is overheated or the supply indicator lamp does not glow

1. Pull the mains plug of the VCU control unit out of the mains socket and wait for about 30 minutes.
2. Insert the mains plug into the mains socket.

Was the VCU control unit overheated?

Yes: Report to the customer service (↳ **Manufacturer Address, page 5**)

No: **Hypothesis 1-C**

Hypothesis 1-C

Actuator faulty

1. Troubleshoot the actuator (refer to relevant operation manual).

Is the actuator defective?

Yes: Replace the actuator and report to the customer service (↳ **Manufacturer Address, page 5**)

No: **Hypothesis 1-D**

Hypothesis 1-D

Life exceeded.

1. Check whether the VCU control unit is older than 10 years or has gone through more than 100 000 double-strokes.

Has the life been exceeded?

Yes: **Manufacturer Address, page 5**

No: **Hypothesis 1-G**

Hypothesis 1-E

The actuator cannot be made to move again by any of the aforementioned measures.

1. Contact the manufacturer immediately (↳ **Manufacturer Address, page 5**).

Has the life been exceeded?

Yes: **Manufacturer Address, page 5**

2 – Control unit works but it is not possible to operate it without connecting to the mains.

Hypothesis 2-A

VCU control unit is not equipped for rechargeable battery operation.

1. Remove the safety protective cover.
2. Check whether the connection socket 13 is in place (↳ **position 14 Fig. 3-1, page 9**).

Is the control unit equipped for rechargeable battery operation?

Yes: **Hypothesis 2-B**

No: Operation when not connected to the mains is not possible for this control unit (↳ **Manufacturer Address, page 5**)

Hypothesis 2-B

Rechargeable is not inserted correctly.

1. Check whether the cable of the rechargeable battery is correctly inserted into the socket 13 connection.
2. If unsure: Remove the sealing ring to reduce the insertion effort. After the attempt re-assemble the sealing ring.

Is the rechargeable battery correctly inserted?

Yes: **Hypothesis 2-C**

No: Insert plug correctly and resume normal operation.

Hypothesis 2-C

Rechargeable battery is empty.

1. Connect the control unit to the mains voltage (operating LED lights up).
2. Operating unit with LED indicator flashes green, the rechargeable battery is being charged: Leave the control unit plugged in for at least 12 hours until the LED lights up green permanently.

Was the battery empty?

Yes: **4. Normal Operation, page 12**

No: **Hypothesis 2-D**

Hypothesis 2-D

Rechargeable battery is defective.

1. Check the lifespan of the rechargeable battery.

Has the lifespan of the battery been exceeded?

Yes: Buy a new battery (↳ **Manufacturer Address, page 5**).

No: Contact customer services (↳ **Manufacturer Address, page 5**).

3 – VCU control unit carries out the wrong function or no function at all.

Hypothesis 3-A

Parameter set of the VCU control unit is not correct for the actuator unit.

1. Check the type plate of the VCU control unit and the parameter set VCP.
2. Check the type plate of the actuator unit.
3. Contact the manufacturer (↳ **Manufacturer Address, page 5**).

6.1 Repair

Repairs may only be carried out by the manufacturer. In any case, contact customer service. (↳ **Manufacturer Address, page 5**).

7.0 Removing from service, dismantling and disposal

This chapter is intended for technicians and those doing the further processing. It contains all the information that is required for the shutdown, dismantling and disposal of the VCU control unit.

7.1 Shutting down

The VCU control unit must be shut down in the following sequence.

4. AC design: Render the VCU control unit voltage-free (isolate it) by pulling the plug of the control unit from the socket.
DC design: Remove the DC feed cable from the source of DC voltage.
5. Remove the safety protective cover.
 - 1.1. Use a coin or large screwdriver to turn the locking button to the open position.
6. Pull out the plug for the connected components from the VCU control unit.

You can then dismantle or re-install the VCU control unit (↳ **Installation, page 14**).

7.1 Dismantling

Before you start dismantling, shut down the VCU control unit (↳ **7.1 Shutting down**). The VCU control unit should be dismantled in the following sequence:

7. Loosen and remove the fastening screws.

You can then prepare the VCU control unit for the transport (↳ **Transport, page 14**), or store or dispose of it as described in the sections that follow.

7.1 Storage

You can then prepare the VCU control unit for the transport (↳ **Transport, page 14**), or store or dispose of it as described in the sections that follow.

- Ambient temperature: +5 °C to +40 °C
- Atmospheric humidity: 5 % to 85 %



NOTE

Important: Rechargeable batteries can discharge even when stored and can be destroyed if discharged completely. Please ensure that you connect the battery to the mains occasionally. When stored the underground battery with 2.7 Ah must be connected to the mains for 12 hours every four months.

CAUTION

After connecting the rechargeable batteries with the control unit, the control unit must be connected to the mains power supply after 6 week. Otherwise the batteries can be destroyed.

7.2 Disposal

The VCU control unit must be disposed of in a technically proper manner and in accordance with the local specifications.

Please refer in particular to the disposal regulations for the rechargeable batteries.

Please find dismantling instructions and shipping requirements in the relevant sections.

8.0 Appendix

Technical data

Please refer to the following document:

Control units catalogue

PUB IL-06008/3 -EN-April 2022

For further technical information please contact Ewellix.

VCU

Control unit



Benefits

- Compact 5-channel actuator control unit
- Single fault safety
- Overload and over-temperature protection
- Approved for medical applications
- Easy to clean
- Low standby current

Technical data

	Unit	VCU 5	VCU 8	VCU 9
Motor ports (DIN8)	#	3 or 5	3 or 5	3 or 5
Operating device ports (HD15)	#	2	2	2
Battery ports (DSub9)	#	1	1	1
Limit switch ports (HD15)	#	2	2	2
Single fault safety	yes/no	yes	yes	yes
Encoder processing	yes/no	no	no	no
Input voltage	V AC	120	230	230
Frequency	Hz	60	50	50
Input current (max)	A	2,5 resp. 6,5	1,3 resp. 3,3	1,3 resp. 3,3
Standby power	W	2,6 resp. 3,9	2,6 resp. 3,9	2,6 resp. 3,9
Output voltage	V DC	24	24	24
Output current (max)	A	7 resp. 18	7 resp. 18	7 resp. 18
Duty cycle: intermittent	min.	1 min./9 min.	1 min./9 min.	1 min./9 min.
Duty cycle: short time	min.	2	2	2
Ambient temperature	°C	+5 to +40	+5 to +40	+5 to +40
Humidity	%	5 to 85	5 to 85	5 to 85
Degree of protection	IP	×4	×4	×4
Approvals	EN/UL	EN 60601-1 UL 60601-1	EN 60601-1 UL 60601-1	EN 60601-1 UL 60601-1
Weight without battery	kg	2,4 resp. 3,8	2,4 resp. 3,8	2,4 resp. 3,8
Weight with battery	kg	5,4 resp. 8,8	5,4 resp. 8,8	5,4 resp. 8,8

Dimensional drawing

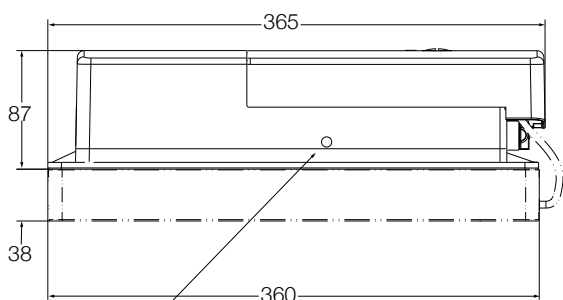

Operating voltage display (LED)

Suitable control units and accessories

	Linear actuators						Columns					Operating switches			
	CALA 36A (24 V DC)	CARE 33A	Magdrive MD22, MD23	RU20, RU21, RU22	RU23, RU24, RU25	MAX 10, MAX 30	ECOMAG	THG 10	TLG 10	TLT 10	TFG 10	TXG 10	EHA3	STJ	STE
VCU 5	•	•	•	•	•	•	•	•	•	•	•	•	•	•	•
VCU 8	•	•	•	•	•	•	•	•	•	•	•	•	•	•	•
VCU 9	•	•	•	•	•	•	•	•	•	•	•	•	•	•	•

Hand switch
 Foot switch
 Desk switch

Connecting diagrams

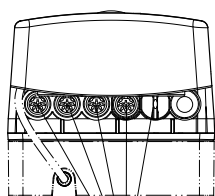

Up to 5 connections with DIN8 plug

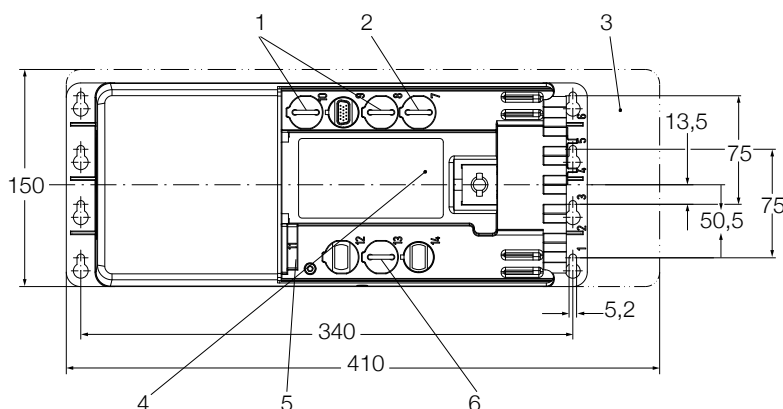

1. Two connections for HD15 operating devices
2. HD15 limit switch connection
3. Additional space for mounting
4. Data plate software
5. Mains connection
6. D-Sub 9 battery connection (optional)

Pinning of HD15 limit switch connection

Function	Pin	Wire color (ZKA-160627-2500)	Connecting diagram
24 V DC (common)	1,3,5,7,9	white/yellow, white/green, grey-pink, black, blue	
Switch 1	2	brown-green	
Switch 2	4	red-blue	
NC	6,8,10,11,12,14	violet, red, pink, grey, yellow, brown	
20-40 V DC, max. 50 mA	13	green	
GND	15	white	

Accessories

	Plug	Designation	Order number
Mains cable, 2 pole	Euro	ZKA-160608-3500	0105726
Mains cable, 3 pole	Schuko	ZKA-160637-3500	0118821
Mains cable, 3 pole	SEV	ZKA-160638-3500	0118822
Mains cable, 3 pole	UL	ZKA-160639-3500	0105588
Mains cable, 3 pole	UK	ZKA-160609-3500	0105631
Mains cable, 3 pole	UL, hospital grade	ZKA-160640-3500	0118823
Mains cable, 3 pole	Australian, China	ZKA-160661-3500	0129953
Battery pack 2,7 Ah		ZBA-160208-0400	0118806
Rack for 4,5 Ah battery		ZBA-160207-1000	0121266
Detachable battery 4,5 Ah		ZBA-160209	0119846

Ordering key

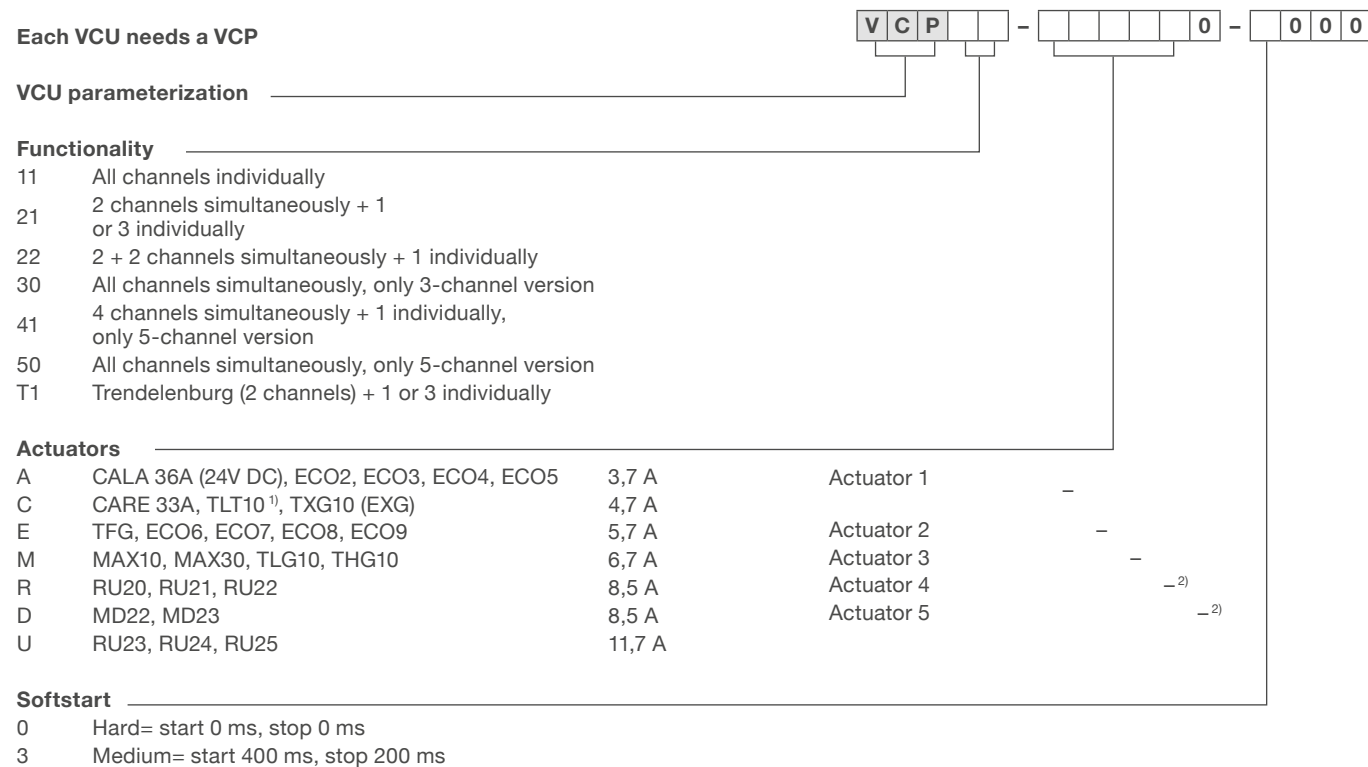
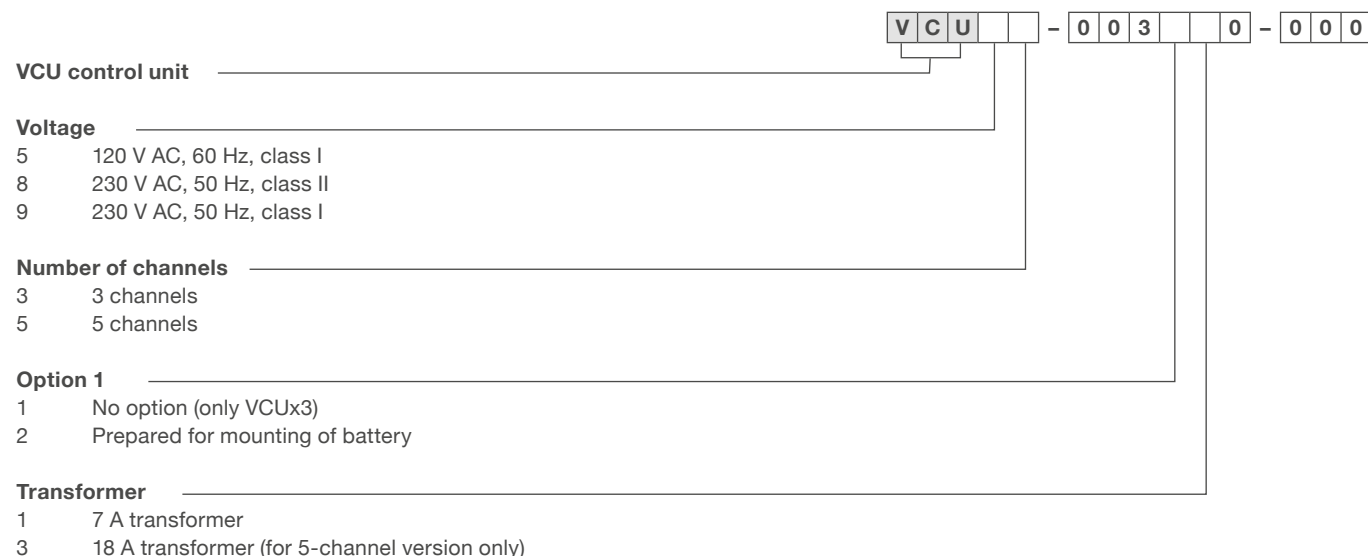

The SCU solution offers many more possibilities than those given in the type keys. Please feel free to ask for more functions like “virtual limit switches”, “external limit switches” and so on.

¹⁾ TLT is a 2-motor actuator. If simultaneous run is needed, VCP21-CC... is recommended

²⁾ for VCUx3: insert zero

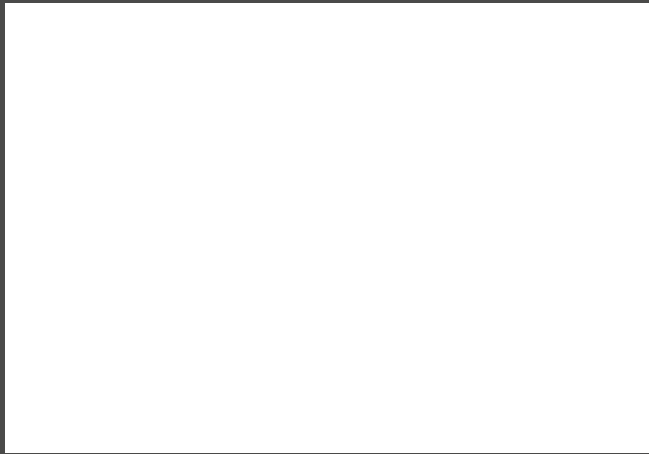

ewellix.com

© Ewellix

All contents of this publication are the property of Ewellix, and may not be reproduced or given to third parties (even extracts) without permission. Although great care has been taken in the production of this catalog, Ewellix does not take any responsibility for damage or other loss resulting from omissions or typographical errors. The photo may differ slightly in appearance from the actual product. Due to continuous improvements being made in our products, the product's appearance and specifications are subject to change without notice.

PUB TC-08008/2-EN-April 2022