

## Lifting columns TLG



High bending load



Powerful



Standards  
EN/IEC 60601-1  
UL 60601-1

# TLG

## Telemag lifting column



### Benefits

- High bending load
- Powerful

### Standards

- EN/IEC 60601-1
- UL 60601-1

### Technical data

|                                    | Unit         | TLG 10/11-A               | TLG 10-B                  | TLG 10/11-C             |
|------------------------------------|--------------|---------------------------|---------------------------|-------------------------|
| Rated push load                    | N            | 4 000                     | 2 500                     | 1 500                   |
| Rated pull load                    | N            | 0                         | 0                         | 0                       |
| Bending load                       | Nm           | up to 2 800 <sup>1)</sup> | up to 1 750 <sup>1)</sup> | up to 950 <sup>1)</sup> |
| Speed (full load to no load)       | mm/s         | 10 to 14                  | 13 to 17                  | 25 to 33                |
| Lifting column version             | # of section | 2 or 3-section            | 2 or 3-section            | 2 or 3-section          |
| Stroke                             | mm           | 200 to 700                | 200 to 700                | 200 to 700              |
| Retracted length                   | mm           | S+180                     | S+180                     | S+180                   |
| Voltage                            | V DC         | 24                        | 24                        | 24                      |
| Power                              | W            | 156                       | 156                       | 156                     |
| Current                            | A            | 6                         | 6                         | 6                       |
| Duty cycle: intermittent operation | min.         | 1 min./9 min              | 1 min./9 min              | 1 min./9 min            |
| Ambient temperature                | °C           | +10 to +40                | +10 to +40                | +10 to +40              |
| Degree of protection               | IP           | 30                        | 30                        | 30                      |
| Protection class                   | -            | SELV                      | SELV                      | SELV                    |
| Type of control                    | -            | electrical                | electrical                | electrical              |
| Weight                             | kg           | 15 to 30                  | 15 to 30                  | 15 to 30                |

<sup>1)</sup> For details, please see bending load diagrams (↳ page 4)

### Dimensional drawing

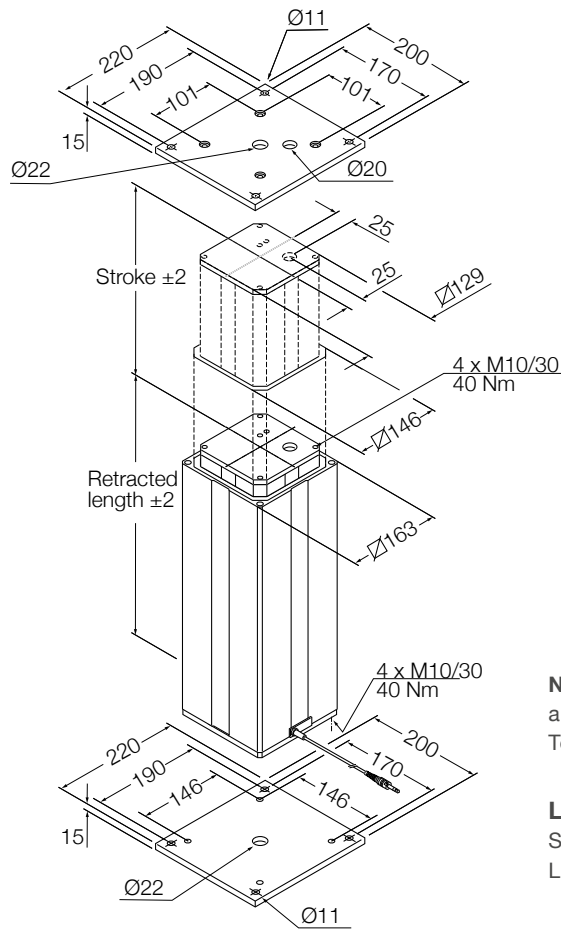
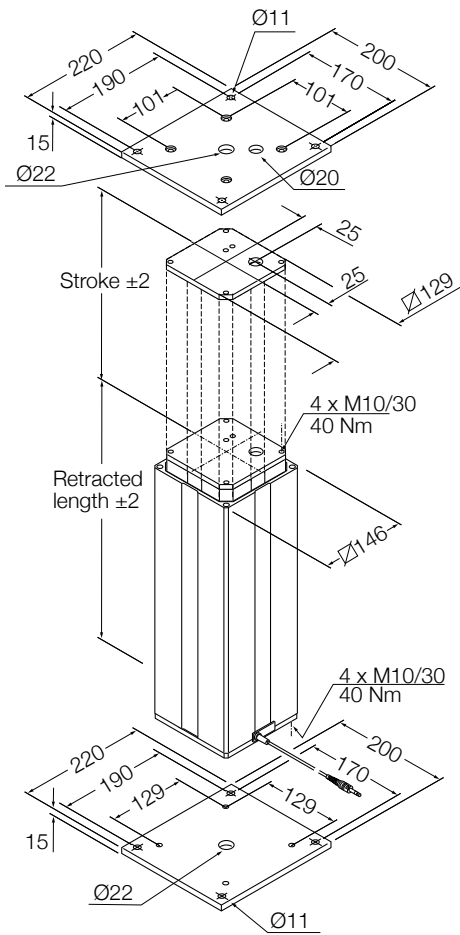

**Note:** mounting plates are not included. To be ordered separately.

**Legend:**  
S = stroke  
L = retracted length

### Connecting diagrams

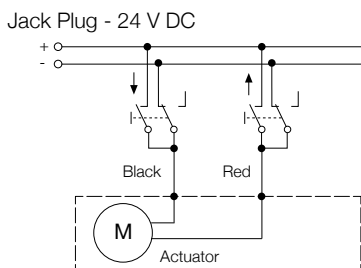
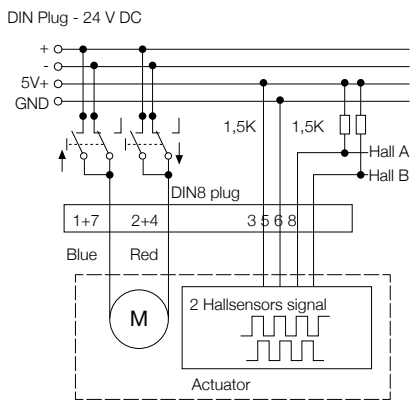

### Suitable control units and accessories

| TLG                | Control units |     |     |     |
|--------------------|---------------|-----|-----|-----|
|                    | SCU           | VCU | BCU | MCU |
| Operating switches |               |     |     |     |
| EHA 1              | •             | •   | •   | •   |
| EHA 3              | •             | •   | •   | •   |
| STF                | •             | •   | •   | •   |
| STJ                | •             | •   | •   | •   |
| STA                |               |     |     | •   |
| STE                | •             | •   | •   |     |

Hand switch    
 Foot switch    
 Desk switch

<sup>1)</sup> Only valid with TLG11. TLG10 must be operated by a BCU, MCU, SCU or VCU control unit.

Performance diagrams

Safety factor load conditions

Speed-load diagram

Speed [mm/s]

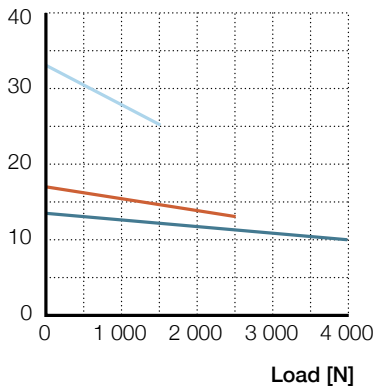

Current-load diagram

Current consumption [A]

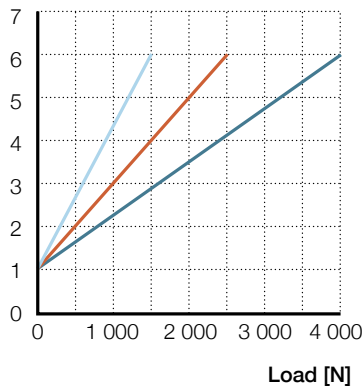

Safety factor

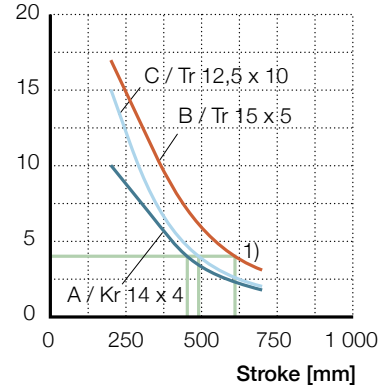

— A — B — C

1) Safety factor =4

Bending load diagrams

Bending load diagram TLG ...AD

Load [N]

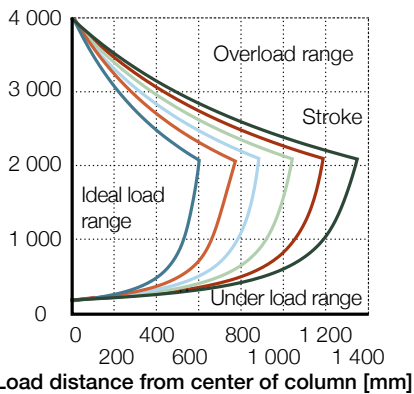

Bending load diagram TLG ...BD

Load [N]

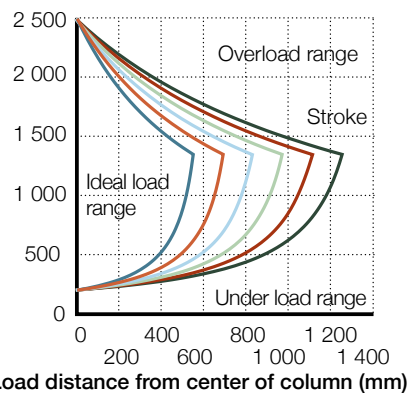

Bending load diagram TLG ...CD

Load [N]

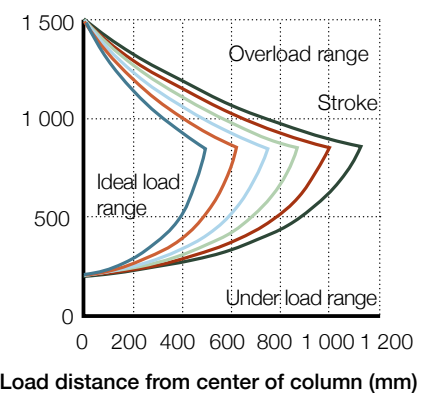

Stroke: — 200 — 300 — 400 — 500 — 600 — 700

Bending load diagram TLG...AA/BA/CA

Load [N]

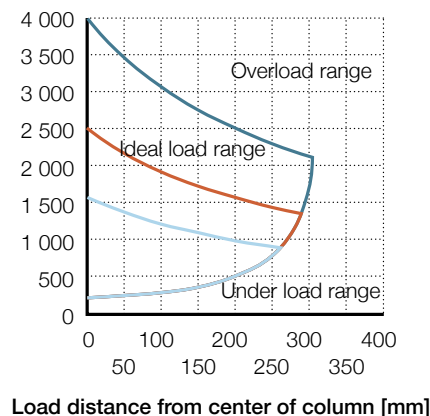

— TLG1-AA  
— TLG1-BA  
— TLG1-CA

Load distance from center of column [mm]

## Accessories

|  | Designation | Order number |
|--|-------------|--------------|
| Top mounting plate for 2 × tube set    | ZPL-290268  | 0125624      |
| Bottom mounting plate for 2 × tube set | ZPL-290351  | 0125625      |
| Top mounting plate for 3 × tube set    | ZPL-290268  | 0125624      |
| Bottom mounting plate for 3 v tube set | ZPL-290265  | 0125623      |
| Screw (4/plate) for mounting plate     | ZBE-510707  | 0125360      |

## Ordering key



**Type** \_\_\_\_\_

**Voltage** \_\_\_\_\_

- 0 24 V DC
- 1 24 V DC with integrated current cut-off (only for 4 000 N and 1 500 N load version)

**Load** \_\_\_\_\_

- A 4 000 N
- B 2 500 N
- C 1 500 N

**Tube set** \_\_\_\_\_

- A Tube set 2×
- D Tube set 3×

**Stroke [S]** \_\_\_\_\_

- 2 200 mm
- 3 300 mm
- 4 400 mm
- 5 500 mm
- 6 600 mm
- 7 700 mm

**Cable / connecting plug** \_\_\_\_\_

- 1 Straight, 1,0 m / jack plug
- 2 Straight, 2,3 m / jack plug
- A Coiled, 0,6 m / jack plug
- 3 Straight, 1,0 m / DIN8 plug
- 4 Straight, 2,3 m / DIN8 plug
- B Coiled, 0,6 m / DIN8 plug

**Option** \_\_\_\_\_

- 0 No option
- A 1-Hall encoder, 8 pulses, cable with jack plug
- B Potentiometer, 1 kΩ, 2 Watt, 0,25 % linearity, 10 turns
- C Cable feedthrough, 5 × 0,75 mm<sup>2</sup>, led out, top +160 mm, bottom +800 mm
- D Cable feedthrough, 1-Hall encoder, 8 pulses, cable with jack plug
- E Cable feedthrough, potentiometer
- F 2-Hall encoder, cable with DIN8 plug
- G Cable feedthrough, 2-Hall encoder, cable with DIN8 plug

Options shown in red are only available on demand. Contact Ewellix for more information on minimum quantities and additional cost.



**ewellix.com**

© Ewellix

All contents of this publication are the property of Ewellix, and may not be reproduced or given to third parties (even extracts) without permission. Although great care has been taken in the production of this catalog, Ewellix does not take any responsibility for damage or other loss resulting from omissions or typographical errors. The photo may differ slightly in appearance from the actual product. Due to continuous improvements being made in our products, the product's appearance and specifications are subject to change without notice.

PUB IL-07021/2-EN-November 2021