

EWELLIX

A Schaeffler Company

Car transfer unit solutions



Compactness



Integration



High load



Robust

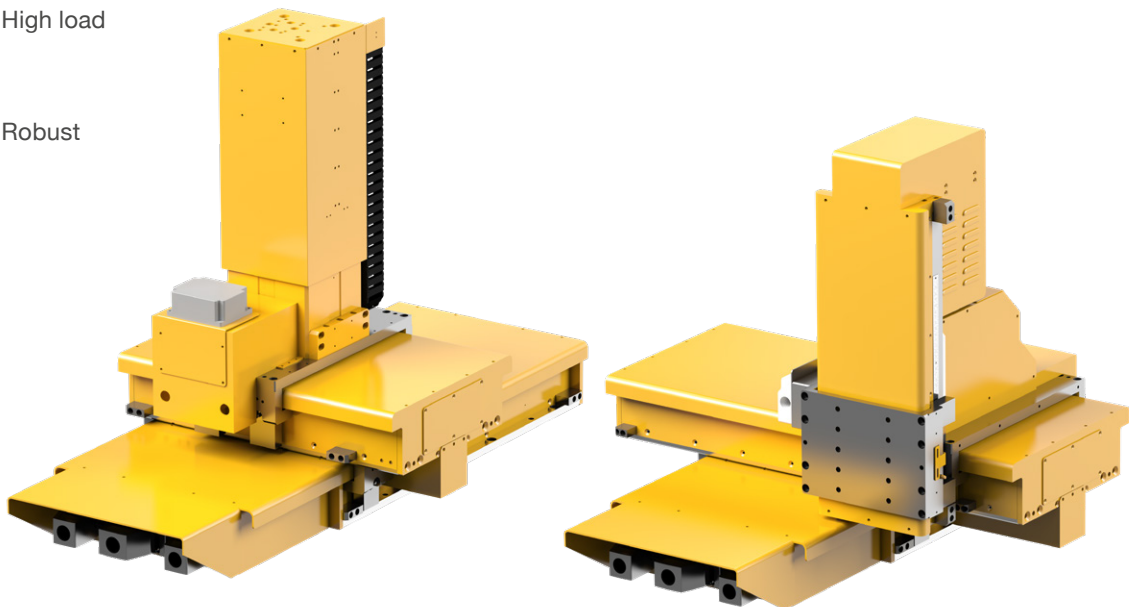

The heritage of innovation

Ewellix is a global innovator and manufacturer of linear motion and actuation solutions. Our state-of-the-art linear solutions are designed to increase machine performance, maximise uptime, reduce maintenance, improve safety and save energy. We engineer solutions for assembly automation, medical equipment, mobile machinery, distribution and a wide range of other industrial applications.

Technology leadership

We earned our reputation through decades of engineering excellence. Our journey began over 50 years ago as part of the SKF Group, a leading global technology provider. Our history provided us with the expertise to continuously develop new technologies and use them to create cutting edge products that offer our customers a competitive advantage.

In 2019, we became independent and changed our name to Ewellix. We are proud of our heritage. This gives us a unique foundation on which to build an agile business with engineering excellence and innovation as our core strengths.

Global presence and local support

With our global presence, we are uniquely positioned to deliver standard components and custom-engineered solutions, with full technical and applications support around the world. Our skilled engineers provide total life-cycle support, helping to optimise the design, operation and maintenance of equipment thus improving productivity and reliability while reducing costs. At Ewellix, we don't just provide products; we engineer integrated solutions that help customers realise their ambitions.

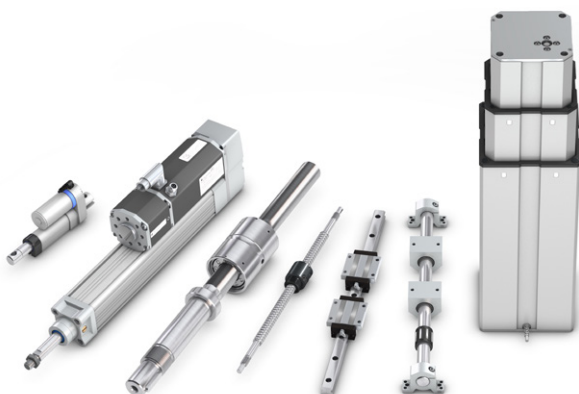

Schaeffler Group – We pioneer motion

Ewellix is since 2023 owned by the Schaeffler Group.

As a leading global supplier to the automotive and industrial sectors, the Schaeffler Group has been driving forward groundbreaking inventions and developments in the fields of motion and mobility for over 75 years.

With innovative technologies, products, and services for electric mobility, CO₂-efficient drives, Industry 4.0, digitalization, and renewable energies, the company is a reliable partner for making motion and mobility more efficient, intelligent, and sustainable.

Schaeffler manufactures high-precision components and systems for powertrain and chassis applications as well as rolling and plain bearing solutions for a large number of industrial applications.



Product description

CTU positioning systems are designed for the automotive industry. They are equipped with a pair of profile rail guides with 2 carriages each and show a high performance in terms of guiding accuracy and stiffness. The profile rail guide system is available with a wide range of ball screws to match

high dynamic and positioning accuracy. CTU systems have integrated motor, controller, cables, mechanical brake, shock absorber and steel cover. CTU systems are available with lifting columns or linear modules for vertical axis.

Features

- Compact design with aluminum or steel as base material
- Integrated motor, controller, cables, mechanical brake and shock absorber
- Lifting column or linear module as option of vertical axis
- Inline and right-angle gear boxes with customized motor adapter

Benefits

- Made for long service life and high loads
- Easy maintenance by outside-point lubrication
- Precise alignment and secure fastening of attachments
- High precision in positioning and repeatability

LCTU unit

Load capacity 200 kgf

LCTU unit

Ewellix LCTU systems are innovative and powerful multi-axis systems for Automotive production line.

LCTU systems are embedding our linear guides as a ready to use solution for precise motion. The profile rail guide system is available with a wide range of ball screws to match high static, dynamic and positioning accuracy. LCTU systems have integrated motor, controller, cables, connectors, mechanical brake and steel cover. LCTU systems are available with linear modules for vertical axis.

Benefits

- Made for long service life and high loads
- High speed for dynamic movement
- High precision in positioning and repeatability
- Easy maintenance by outside-point lubrication

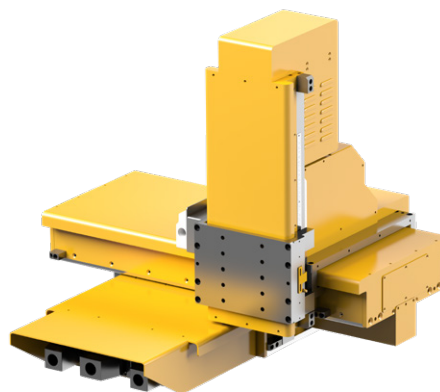

Technical data

	Symbol	Unit	X axis	Y axis	Z axis
Performance Data					
Max. linear speed	V_{max}	mm/s	300 at 3 600rpm	300 at 3 600rpm	300 at 3 600rpm
Max. payload	P_{max}	kg	250	250	200
Max. acceleration	a_{max}	m/s ²	10	10	10
Duty cycle	D_{unit}	%	100	100	100
Mechanical Data					
Profile rail guide	-	-	Size 25	Size 25	Size 25
Screw type	-	-	Ball screw	Ball screw	Ball screw
Screw diameter	d_{screw}	mm	25	25	25
Screw lead	P_{screw}	mm	5~10	5~10	5~10
Stroke	s	mm	100...800	200...600	100...600
Repeatability (same direction and load)	-	mm	± 0.02	± 0.02	± 0.02
Base	-	-	Aluminium or Steel	Aluminium or Steel	Aluminium or Steel
Cover	-	-	Steel	Steel	Steel
Environment					
Ambient temperature	$T_{ambient}$	°C	0 to +50	0 to +50	0 to +50
Max. humidity	ϕ	%	95	95	95

Dimensional drawing

LCTU Left Type

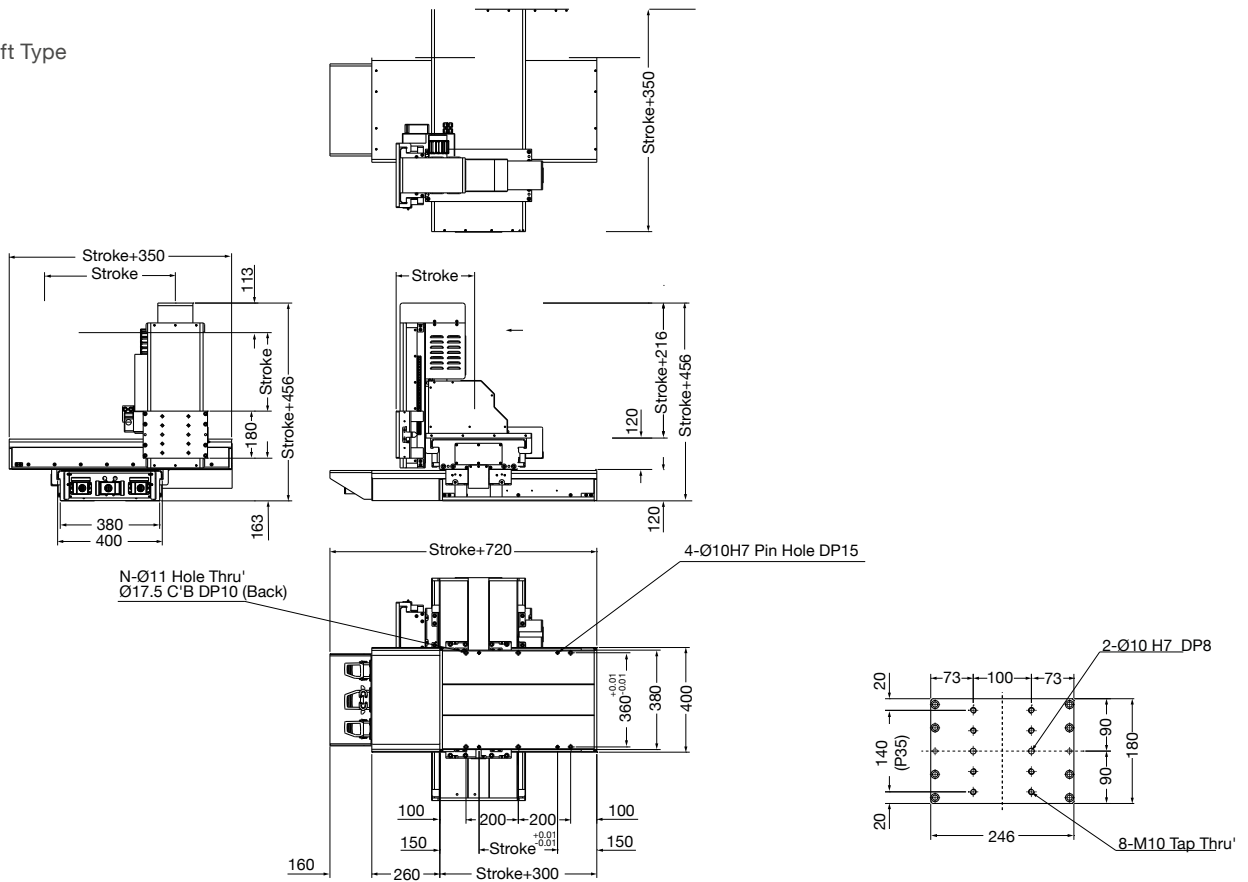

LCTU Right Type

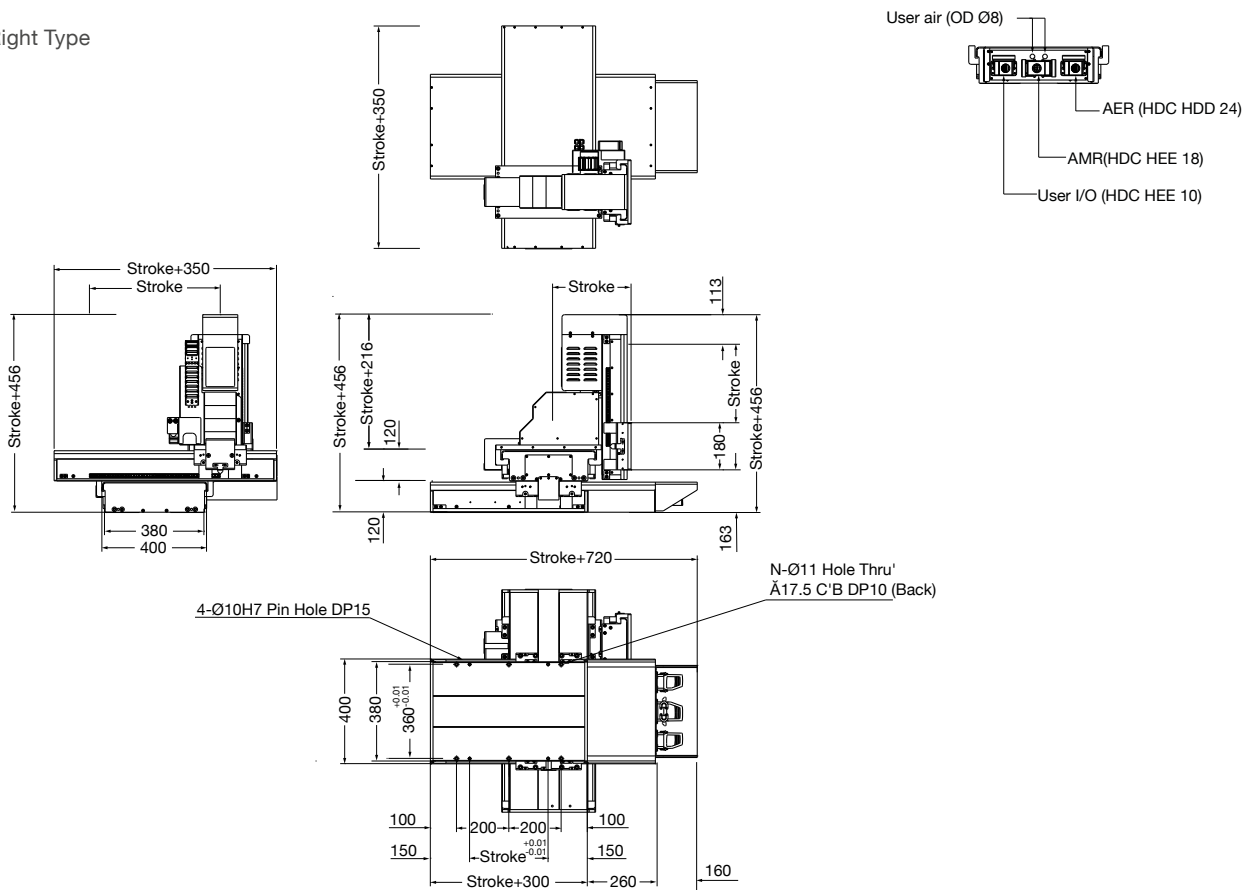

HCTU unit

Load capacity 200 kgf

HCTU unit

Ewellix HCTU systems are innovative and powerful multi-axis systems for Automotive production line.

HCTU systems are embedding our linear guides as a ready to use solution for precise motion. The profile rail guide system is available with a wide range of ball screws to match high static, dynamic and positioning accuracy. HCTU systems have integrated motor, controller, cables, connectors, mechanical brake, shock absorber and steel cover. HCTU systems are available with lifting columns for vertical axis.

Benefits

- Made for long service life and high loads
- Shock absorber and mechanical brake for external impact
- High precision in positioning and repeatability
- Easy maintenance by outside-point lubrication

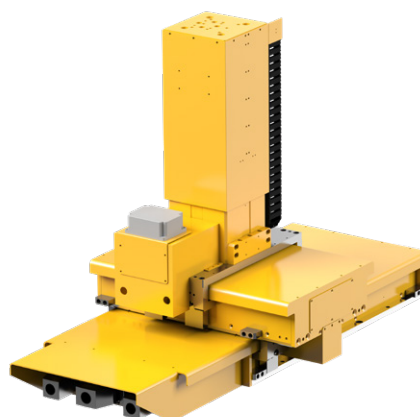

Technical data

	Symbol	Unit	X axis	Y axis	Z axis
Performance Data					
Max. linear speed	V_{max}	mm/s	300 at 3 600rpm	300 at 3 600rpm	60 at 3 600rpm
Max. payload	P_{max}	kg	250	250	200
Max. acceleration	a_{max}	m/s ²	10	10	5
Duty cycle	D_{unit}	%	100	100	100
Mechanical Data					
Profile rail guide	-	-	Size 25	Size 25	Size 25
Screw type	-	-	Ball screw	Ball screw	Ball screw
Screw diameter	d_{screw}	mm	25	25	20
Screw lead	P_{screw}	mm	5~10	5~10	10(1/10)
Stroke	s	mm	100...800	200...600	100...600
Repeatability (same direction and load)	-	mm	± 0.02	± 0.02	± 0.05
Base	-	-	Aluminium or Steel	Aluminium or Steel	Aluminium or Steel
Cover	-	-	Steel	Steel	Steel
Environment					
Ambient temperature	$T_{ambient}$	°C	0 to +50	0 to +50	0 to +50
Max. humidity	ϕ	%	95	95	95



For vertical axis, please, refer to CPSM technical data into **IL-05001/2-EN-June 2021 High performance actuator**

Dimensional drawing

HCTU Left Type

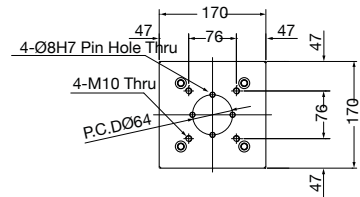
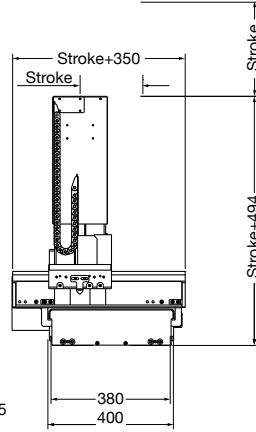
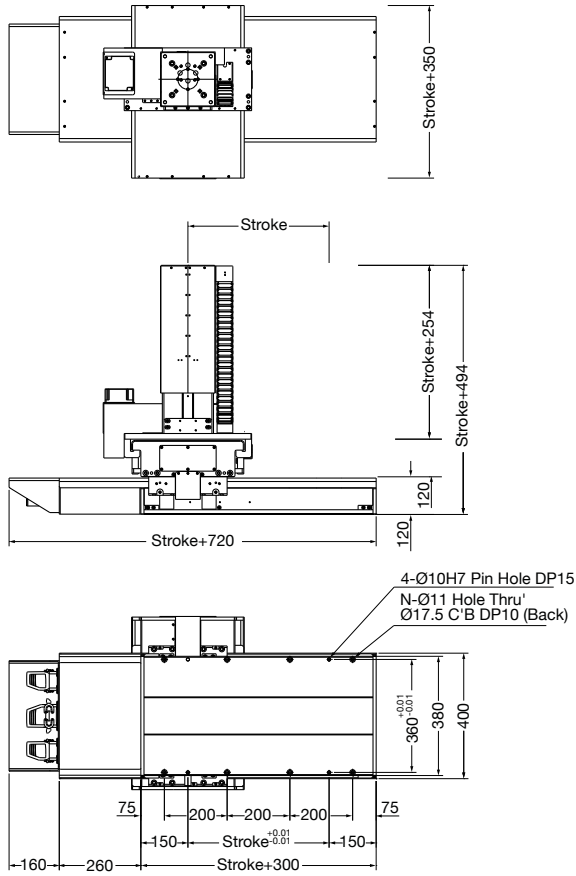

HCTU Right Type

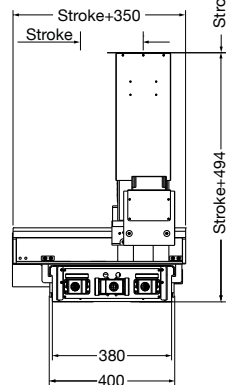
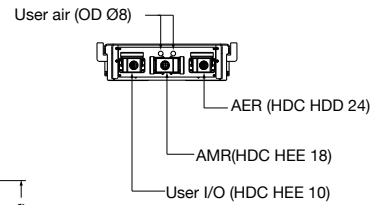
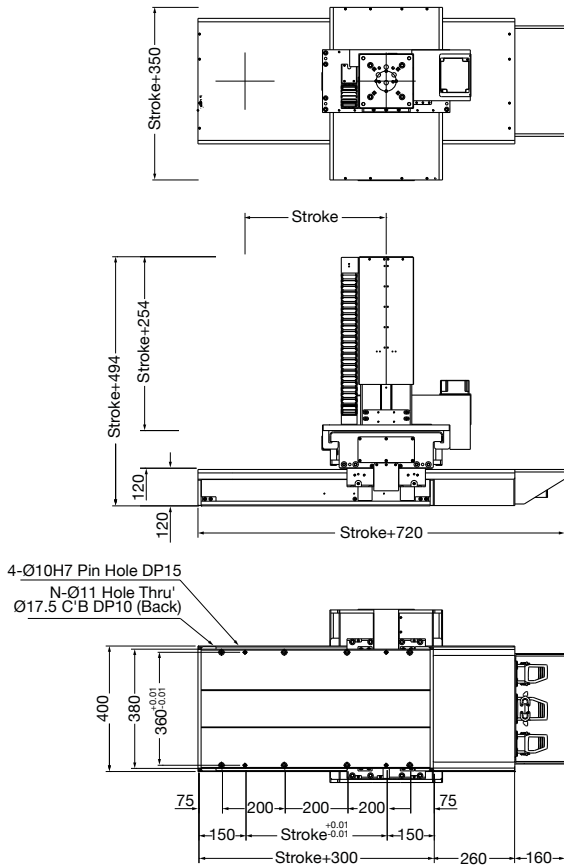

Product description

The high controllability and construction make CTU systems for realizing a smart chassis supporting function in automotive production line.

The need of handling different types of car chassis Body in White (BIW) on the same line requires a flexible system setup that allows a quick resetting with precise positioning.

The optional linear modules for vertical axis provides the high speed by precision ball screw and the integrated dampening system protects the lifting column from mechanical shocks during the loading and unloading phases, ensuring high reliability and longer life-time in operation.

The usage of customer-defined servo motors allows for easier integration into the control network, reducing the commissioning time of the transfer unit.

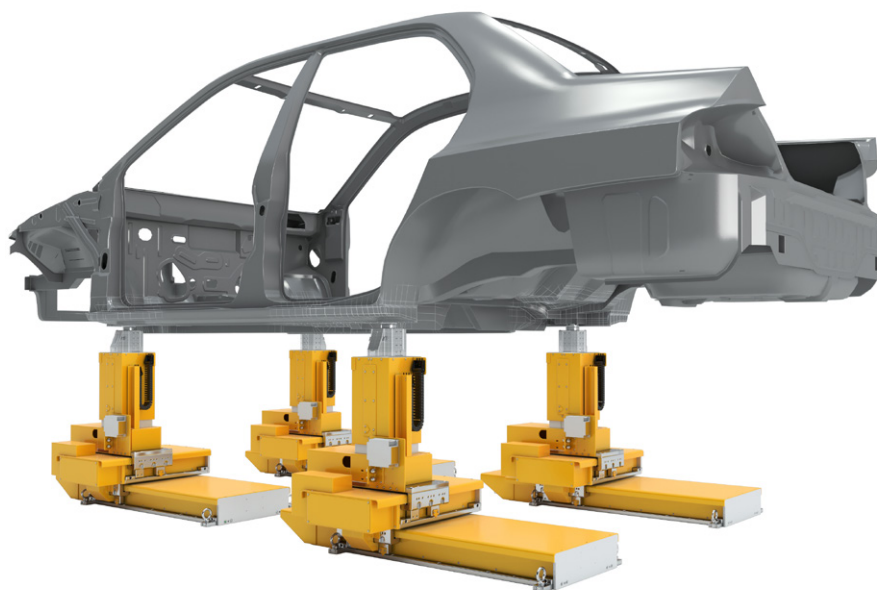

HCTU for AGV application or Car Pallet

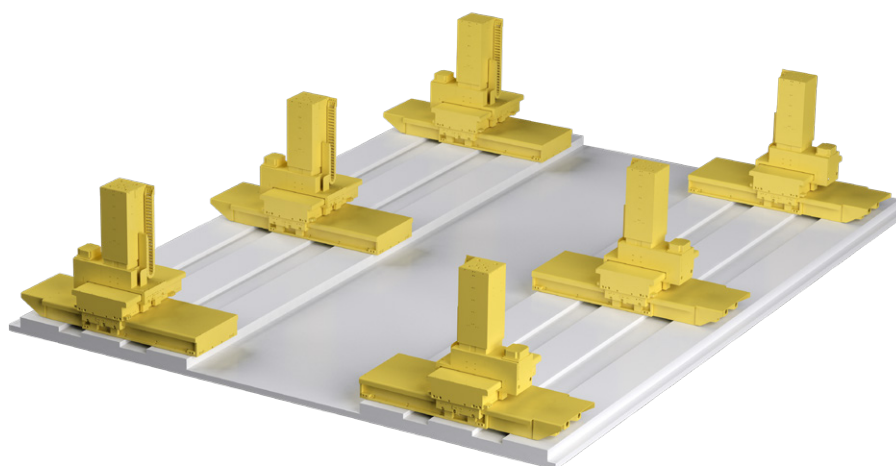

LCTU for car chassis (BIW) lifting application

Ordering key

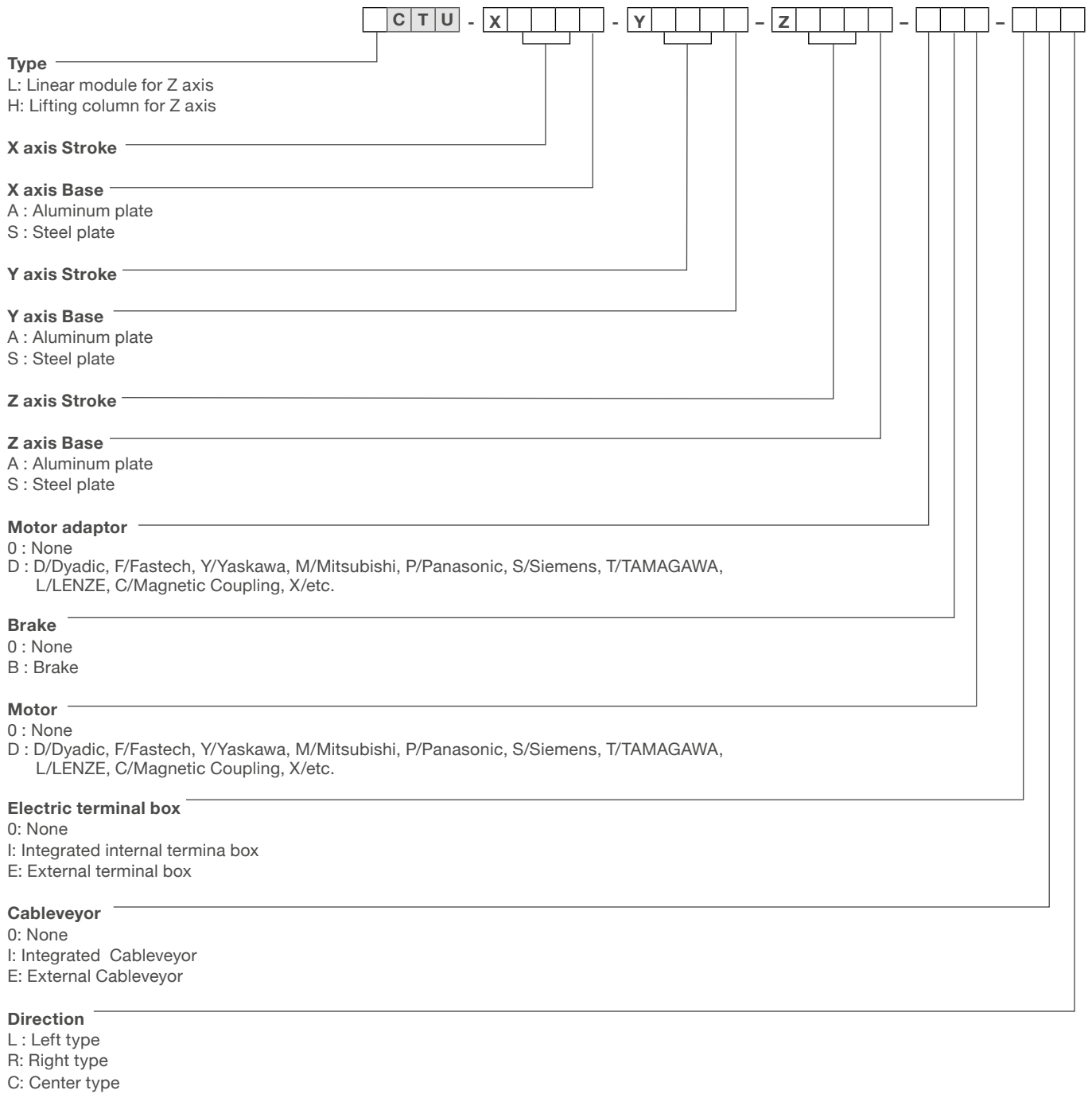

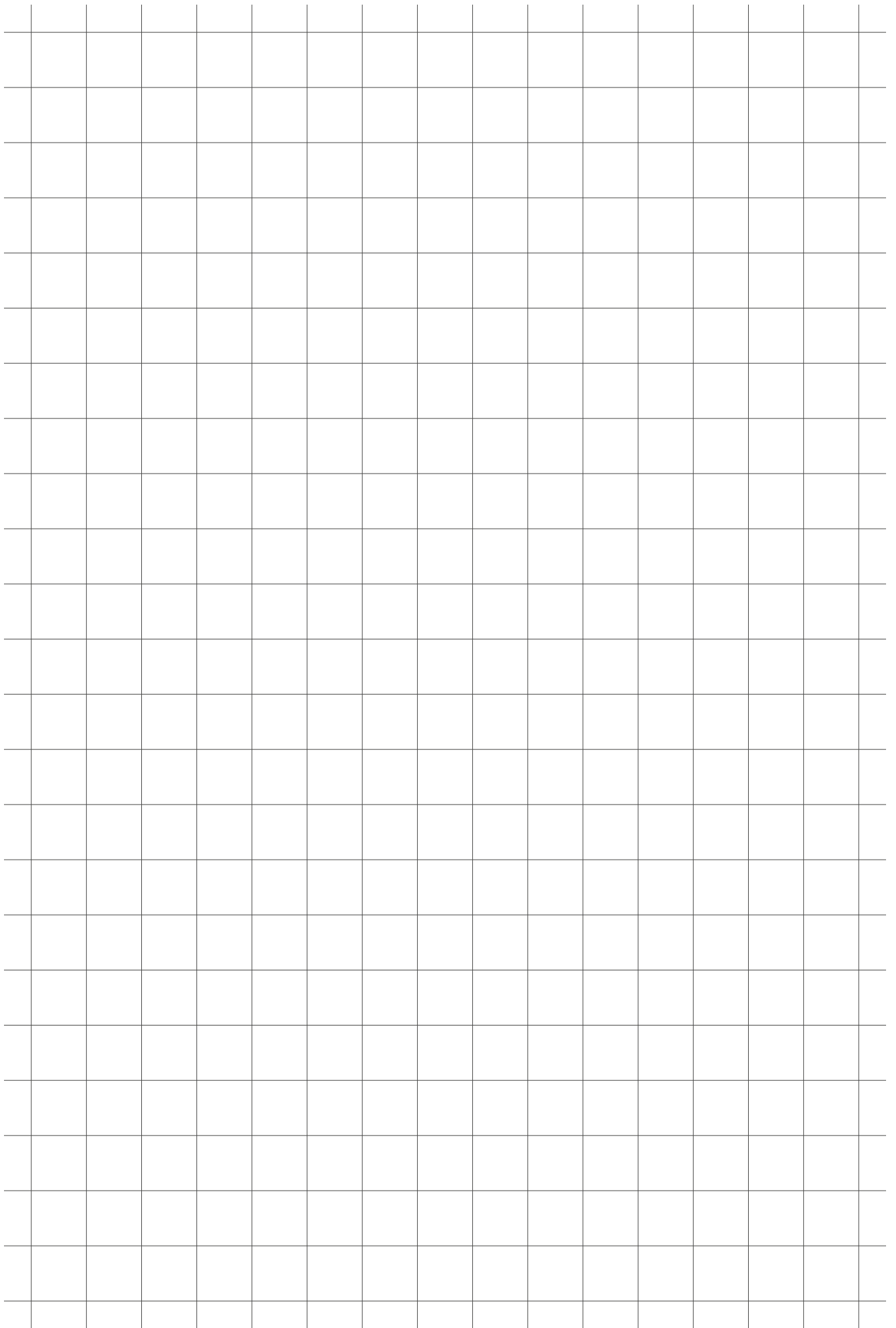

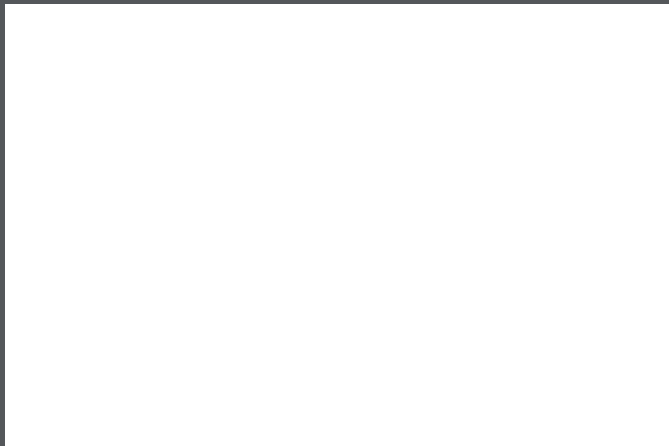

ewellix.com

© Ewellix

All contents of this publication are the property of Ewellix, and may not be reproduced or given to third parties (even extracts) without permission. Although great care has been taken in the production of this catalog, Ewellix does not take any responsibility for damage or other loss resulting from omissions or typographical errors. The photo may differ slightly in appearance from the actual product. Due to continuous improvements being made in our products, the product's appearance and specifications are subject to change without notice.

PUB IL-07001/3-EN-February 2023

Certain image(s) used under license from Shutterstock.com.
Schaeffler and Schaeffler logo are trademarks of the Schaeffler Group