

**EWELLIX**

A Schaeffler Company

# Profile rail guides - LLR catalogue





# Contents

<b>1 Introduction .....</b>	<b>4</b>	<b>4 Mounting instruction and maintenance .....</b>	<b>54</b>
1.1 Product description .....	5	4.1 Design rules .....	55
1.2 Design .....	6	4.1.1 General instructions .....	55
1.2.1 Components and material specifications .....	7	4.1.2 Assembly examples .....	55
1.3 Features and benefits .....	8	4.1.3 Stop edges, corner radii, screw sizes and tightening torques.....	56
1.4 Product range .....	9	4.1.4 Pinning.....	58
<b>2 Selection guide .....</b>	<b>10</b>	4.1.5 Loading of the screw connections between rail and substructure .....	60
2.1 Technical data .....	11	4.1.6 Height deviation .....	61
2.1.1 General information .....	11	4.1.7 Parallelism of mounted rails measured on the rails and the carriages.....	62
2.1.2 Load rating .....	12	4.1.8 Mounting of lubrication adapter.....	63
2.1.3 Preload classes .....	13	4.1.9 Mounting bellow.....	64
2.1.4 Accuracy.....	15	4.2 Maintenance and repairs .....	65
2.1.5 Selection criteria for combination of accuracy classes.....	16	4.3 Ordering key .....	68
2.2 Calculation of bearing loads .....	17		
<b>3 Product range .....</b>	<b>18</b>		
3.1 Carriage data .....	19		
3.1.1 Carriage LLRHC ... SA .....	22		
3.1.2 Carriage LLRHC ... A .....	24		
3.1.3 Carriage LLRHC ... LA .....	26		
3.1.4 Carriage LLRHC ... SU .....	28		
3.1.5 Carriage LLRHC ... U .....	30		
3.1.6 Carriage LLRHC ... LU .....	32		
3.1.7 Carriage LLRHC ... R .....	34		
3.1.8 Carriage LLRHC ... LR .....	36		
3.2 Rail data .....	39		
3.2.1 LLRHR rails .....	40		
3.2.2 LLRHR D2 rails .....	42		
3.3 Accessories .....	45		
3.3.1 Scraper plate .....	46		
3.3.2 Two-piece front seal .....	47		
3.3.3 Seal kit .....	48		
3.3.4 Bellows .....	49		
3.3.5 Lubrication adapter .....	50		
3.3.6 Cover strip .....	51		
3.3.7 Expanding mandrel to create a slide on the cover strip .....	52		
3.3.8 Cover strip retaining clamps .....	53		

# The heritage of innovation

Ewellix is a global innovator and manufacturer of linear motion and actuation solutions. Our state-of-the-art linear solutions are designed to increase machine performance, maximise uptime, reduce maintenance, improve safety and save energy. We engineer solutions for assembly automation, medical equipment, mobile machinery, distribution and a wide range of other industrial applications.

## Technology leadership

We earned our reputation through decades of engineering excellence. Our journey began over 50 years ago as part of the SKF Group, a leading global technology provider. Our history provided us with the expertise to continuously develop new technologies and use them to create cutting edge products that offer our customers a competitive advantage.

In 2019, we became independent and changed our name to Ewellix. We are proud of our heritage. This gives us a unique foundation on which to build an agile business with engineering excellence and innovation as our core strengths.

## Global presence and local support

With our global presence, we are uniquely positioned to deliver standard components and custom-engineered solutions, with full technical and applications support around the world. Our skilled engineers provide total life-cycle support, helping to optimise the design, operation and maintenance of equipment thus improving productivity and reliability while reducing costs. At Ewellix, we don't just provide products; we engineer integrated solutions that help customers realise their ambitions.



## Schaeffler Group – We pioneer motion

Ewellix is since 2023 owned by the Schaeffler Group.

As a leading global supplier to the automotive and industrial sectors, the Schaeffler Group has been driving forward groundbreaking inventions and developments in the fields of motion and mobility for over 75 years.

With innovative technologies, products, and services for electric mobility, CO<sub>2</sub>-efficient drives, Industry 4.0, digitalization, and renewable energies, the company is a reliable partner for making motion and mobility more efficient, intelligent, and sustainable.

Schaeffler manufactures high-precision components and systems for powertrain and chassis applications as well as rolling and plain bearing solutions for a large number of industrial applications.



# Trusted engineering expertise

Our industry is in motion; pushing towards solutions that reduce environmental impact and leverage new technology. We provide technical and manufacturing expertise to overcome our customers' challenges.

## Engineering for the future

We work in a **wide range of industries**, where our solutions provide key functionality for business critical applications.

For the **medical industry**, we provide precision components for use in core medical equipment.

Our unparalleled understanding of **assembly automation** systems is based on decades of research into advanced automation components and techniques.

Our deep knowledge of **mobile machinery** provides powerful and reliable electromechanical solutions for the harshest conditions. In an **industrial distribution** setting, we supply linear expertise to our partners, empowering them to serve customers with greater efficiency.

## We offer excellence

We have a **unique understanding of linear equipment** and how it's integrated in customers' applications to provide the best performance and machine efficiency.

**We assist our customers** by creating equipment that runs faster, longer and that is safe and sustainable.

We provide a wide variety of **linear motion components** and **electromechanical actuators** for equipping any automation application, thus helping our customers **increase productivity, reduce their footprint, energy use and maintenance.**

### Actuation systems



### Ball and roller screws



### Linear guides and systems

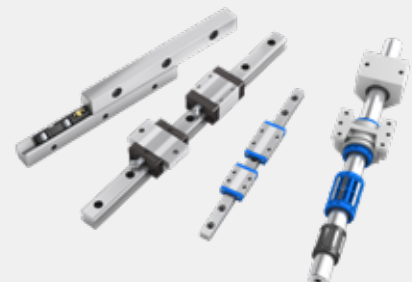

1

# Introduction

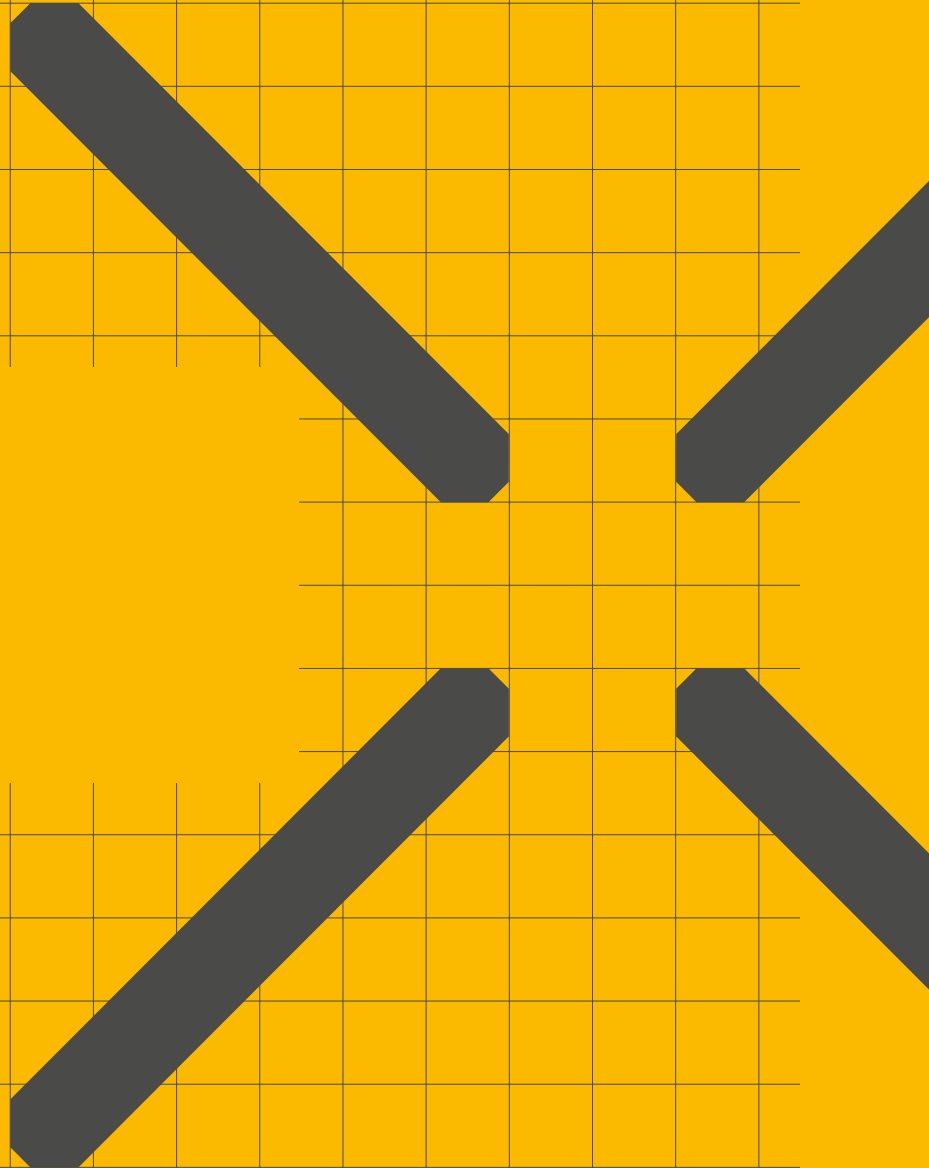

# 1.1 Product description

As the world's leading manufacturer of rolling bearings, Ewellix supplies practically every type of rolling bearing for rotary and linear movements. The standard profile rail guides produced by Ewellix are brought together in this catalogue. Ewellix profile rail guides are accuracy rolling bearings for linear movements and are therefore suitable for use in most types of machinery. With these profile rail guides it is possible for Ewellix to offer a guide system which achieves a good price/performance ratio.

Profile rail guides from Ewellix are available in many designs and sizes, and thanks to their unlimited stroke they can be adapted to any linear movement. They consist of a rail guide with ground raceways on which one or several guide carriages can be moved with an unlimited stroke. The guide carriages are made of tempered bearing steel into which the hardened raceways of the ball circuits are inserted. Fixing holes in the attachment surfaces enable machine parts to be directly mounted onto the carriages. Fundamentally, profile rail guides constitute a coupled angular ball bearing in back-to-back arrangement and, depending on the application, are available in different preload classes.

The raceways of the profile rail and of the carriage are arranged at an angle of 45°. As a result, the system has the same load capacity in the four main load directions as well as a high moment load capacity.

Depending on the load conditions and the required service life, a selection can also be made between two design versions. In addition to the standard carriage length, a series with extended carriages is available which exhibits higher load rating. To meet the requirements of operating practice, a range of different guide systems is offered. Their main features are load capacity, screw connections to provide the fastening points on the carriage and the sectional height.

Thanks to the modular design of the systems, subsequent changes are not a problem. This catalogue brings together all the data which we feel is relevant.

If you require additional information please get in touch with one of our sales companies.



## 1.2 Design

Just as with rotary bearings, the raceways of profile rail guides can be arranged in an X- or O-arrangement. The load carrying capacity of these two arrangements are essentially the same. Therefore, there are no basic differences in behavior in the vast majority of load situations, except when they are subjected to moment loads around the X-axis.

The LLR profile rail guides from Ewellix feature an O-arrangement, based on the contact angle of the rolling elements (→ **fig. 1**). The advantage of this arrangement is that especially in one-axis systems, the moment-related rigidity is higher than comparable systems with an X-arrangement.

Due to the design-related bigger lever arm, the O-arrangement provides better rigidity and thus higher accuracy.

Fig. 1

*Schematic illustration of ball-arrangement*

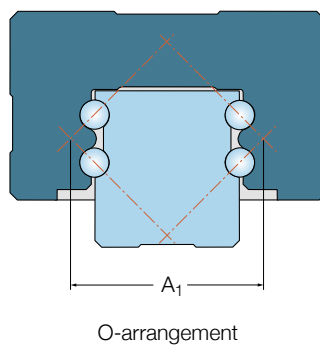





## 1.3 Features and benefits

- Carriages with and without ball chain
- High load capacities in all main directions and high moment load capacities
- High dynamic performances:  $v = 5 \text{ m/s}$ ;  $a_{\text{max}} = 500 \text{ m/s}^2$
- Low noise and smooth, light running due to optimised ball recirculation and ideal ball chain geometry
- Long term lubrication system
- Lube ports with metal threads on all sides.
- Full interchangeability due to standardised rail, with or without rail seal cover strip, for all carriage versions
- Various accuracy and preload classes
- Carriages can be screwed from above or below, depending on type.
- Improved stiffness under lift off and side loading conditions when additional mounting screws are used for the holes in the centre of the carriage
- Integrated all-round sealing through front and longitudinal seals
- Wide range of accessories
- Both grease and oil lubrication possible despite initial grease application
- Wide range of accessories
- Worldwide Ewellix service network
- Both sides of the guide rail can be used as reference edges

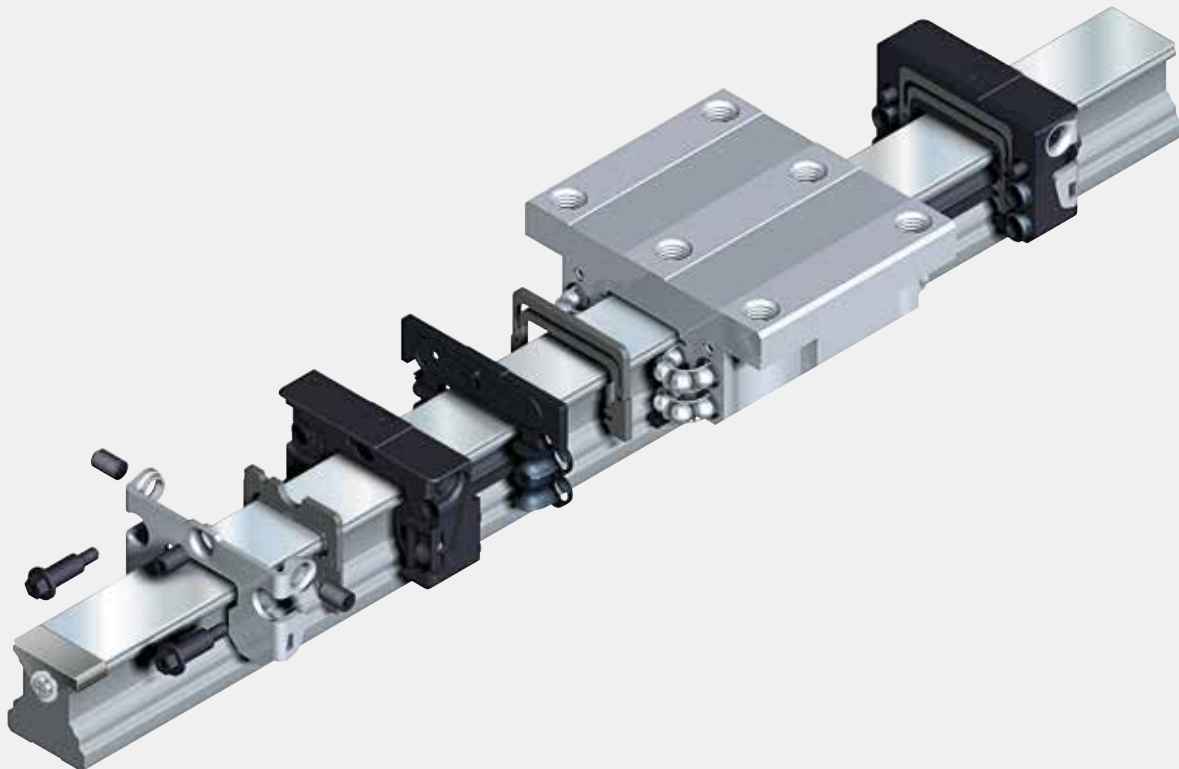

# 1.4 Product range

## LLRHC ... SA

Flange short  
Standard height  
Further information [see page 22](#)



## LLRHC ... A

Flange normal  
Standard height  
Further information [see page 24](#)



## LLRHC ... LA

Flange long  
Standard height  
Further information [see page 26](#)



## LLRHC ... R

Slim line normal  
High  
Further information [see page 34](#)



## Ball chain

Optimises noise level and running behaviour

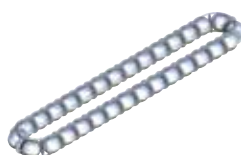

## LLRHC ... LR

Slim line long  
High  
Further information [see page 36](#)

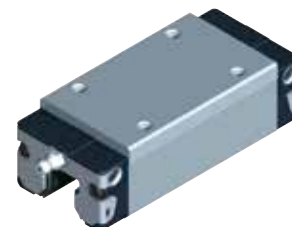

## LLRHC ... SU

Slim line short  
Standard height  
Further information [see page 28](#)



## LLRHC ... U

Slim line normal  
Standard height  
Further information [see page 30](#)

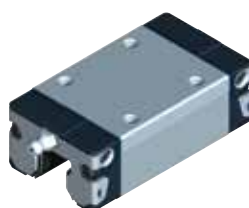

## LLRHC ... LU

Slim line long  
Standard height  
Further information [see page 32](#)

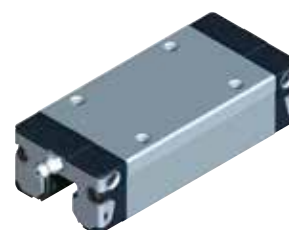

2

## Selection guide



# 2.1 Technical data

## 2.1.1 General information

The general technical data applies to all rail guides (all carriages and rails). Special technical data is listed separately for the individual designs.

### Preload classes

In view of the different user requirements, the ball rail guides can be supplied in four different preload classes.

So as not to reduce the service life, the preload should not amount to more than 1/3 of the bearing load F.

In general, the stiffness of the carriage increases according to the preload increase.

### Guide systems with parallel rails

- In connection with the selected preload class the permissible deviation in parallelism of the rails must also be taken into account (see tables for the various designs).
- For the installation of rail guides in the accuracy class P5 we recommend the version with clearance T0 or the preload class T1 in order to avoid stresses owing to the tolerances.

### Speed

$v_{\max}$ : 5 m/s

### Acceleration

$a_{\max}$ : 500 m/s<sup>2</sup>

Only in the case of preloaded systems. In the case of non-preloaded systems:  $a_{\max} = 50 \text{ m/s}^2$

### Temperature resistance

$t_{\max}$ : 100 °C

This is a maximum value which is only permissible for a short time. In continuous operation a maximum temperature of 80 °C must not be exceeded.

## Friction

The friction coefficient  $\mu$  of the ball rail guide is approx. 0,002 to 0,003 (not including the friction of the seal). As a result of the design with 4 ball rows a 2-point contact exists for all load directions. This reduces friction to a minimum (→ fig. 1).

Fig. 1

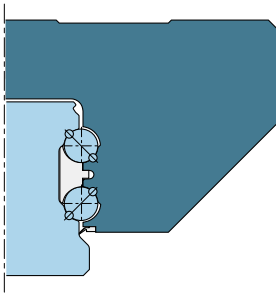

## Seals

Seals should prevent the penetration of dirt and chips into the interior of the carriage in order to avoid premature failure.

### Universal seal

Universal seals are installed as standard in Ewellix carriages.

They have a constant sealing effect on rails with and without cover strip. In addition to efficient sealing, the design also provides for low friction. For applications where low friction is required light-contact seals are available on request.

### Front seal

Front seals can be ordered as accessories and are attached by the customer. They are suitable for use in environments with fine dust or metal particles, as well as coolants or cutting fluids.

**NOTE:** For extreme duty in environments with coarse dirt or metal particles, or where there is massive use of coolants or cutting fluids, Viton seals are available on request. Viton seals have to be attached by the customer.

## Scraper plates

Scraper plates can be ordered as accessories (have to be attached by the customer). They are suitable for use in most environments where coarse dirt or chips are encountered.

## 2.1.2 Load rating

### Definition of the basic dynamic load rating C

The radial load, constant in magnitude and direction, which a linear rolling bearing can in theory accommodate for a basic rating life represented by a travelled distance of 105 m (to DIN 636 Part 1). The basic dynamic load ratings in the tables are generally 30 % higher than the values to DIN. They have been verified in tests.

### Definition of the basic static load rating C<sub>0</sub>

The static load in the direction of loading which corresponds to a calculated load in the centre of the most highly loaded contact point between the rolling element and both raceways (rail) at an osculation of  $\leq 0,52, 4\ 200$  MPa.

**NOTE:** At this load on the contact point a permanent total deformation of the rolling element and raceway occurs which corresponds to about 0,0001 times the rolling element diameter (to DIN 636 Part 2).

### Definition and calculation of the basic rating life

The calculated life achievable with 90 % reliability for a single rolling bearing or a group of evidently identical rolling bearings running under identical conditions given the material generally used today of normal manufacturer's quality and usual operating conditions (to DIN 636 Part 1).

#### Basic rating life at constant speed

The basic rating life L or L<sub>h</sub> can be calculated applying the formula 1, 2 or 3:

$$1) L_{10} = \left( \frac{C}{P} \right)^3 10^5$$

$$2) L_{10h} = \frac{L_{10}}{2 \times s \times n \times 60}$$

#### Basic rating life at changing speed

$$3) L_{10h} = \frac{L_{10}}{60 \times v_m}$$

$$4) v_m = \frac{t_1 \times v_1 + t_2 \times v_2 + \dots + t_n \times v_n}{100}$$

- L<sub>10</sub> = basic rating life (m)
- L<sub>10h</sub> = basic rating life (h)
- C = basic dynamic load rating (N)
- P = equivalent load (N)
- s = stroke length (m)
- n = stroke frequency (double strokes/min)

- $v_m$  = mean speed (m/min)
- $v_1, v_2, \dots, v_n$  = travel speeds (m/min)
- $t_1, t_2, \dots, t_n$  = time proportions for  $v_1, v_2, \dots, v_n$  (%)

The formulae for calculating the service life of profile rail guides apply to a stroke length of  $S \geq 2$  times the carriage length. At lower values the load rating is reduced. Please consult Ewellix.

### Dynamic equivalent bearing load for calculation of the service life

For a fluctuating bearing load the dynamic equivalent loading  $F$  is calculated according to **formula 5**:

$$5) F_m = \sqrt[3]{\frac{F_1^3 \times s_1 + F_2^3 \times s_2 + \dots + F_n^3 \times s_n}{s}}$$

- $F_m$  = constant mean load (N)
- $F_1, F_2 \dots F_n$  = constant loads during stroke lengths  $s_1, s_2, \dots, s_n$  (N)
- $s$  = total stroke length ( $s = s_1 + s_2 + \dots + s_n$ ), during which loads  $F_1, F_2 \dots F_n$  have an effect (mm)

\* given a combined bearing load

### Note on dynamic load capacities and moments

Determination of dynamic load capacities and moments is based on a travel life of 100 000 m. However, frequently this is determined on the basis of only 50 000 m. In this case for comparison: multiply values C, MC and MA by 1.26 in accordance with Ewellix tables. For carriages with ball chain the permissible moments are reduced in accordance with the load ratings.

## 2.1.3 Preload classes

For perfect operating behaviour under various operating conditions in an extremely wide range of applications it is necessary to establish the suitable preload. In general, a slight to medium preload is enough for the majority of applications. For special applications in which high shock loads and vibration can occur it is advisable to use a higher preloading. The preload classes offered by Ewellix are categorised in **table 4**.

### Selection of the preload class

In the designs with clearance no preloading is achieved. Instead, there is clearance of between 1 and 10  $\mu\text{m}$  between the carriage and rail. If two rails and more than one carriage per rail are used this clearance is in most cases equalised by parallelism tolerances.

Preload force referred to the basic dynamic load rating  $C_{dyn}$  of the respective carriage.

#### Example:

- Carriage LLRHC 35 A
- $C = 41\,900\text{ N}$
- Preload  $0,02 \times C = 838\text{ N}$
- This carriage is preloaded with a basic load of approx. 838N.

Table 4

Versions and area of applications

Preload class	Preload force $F_{pr}$
<b>T0 – Clearance</b>	For particularly smooth-running guide systems with low friction and low external influences. Designs with clearance are only available in the accuracy classes P5 and P3.
<b>T1 - Preload 0,02 C</b>	For precise guide systems with low external load and high requirements in respect of overall stiffness.
<b>T2 - Preload 0,08 C</b>	For precise guide systems with high external load and high requirements in respect of overall stiffness; also recommended for single-rail systems. Above-average moment loads are absorbed without any significant elastic deformation. At only medium moment loads the overall stiffness is further improved.
<b>T3 - Preload 0,13 C</b>	For highly rigid guide systems such as precision machine tools or injection mould clamping units. Above-average loads and moments are absorbed with lowest-possible elastic deformation. Version with preload T3 only available in accuracy classes P1, P01 and P001.

## Deflection as a function of preload class and carriage

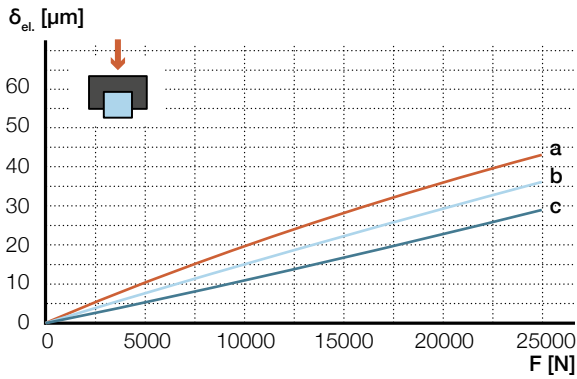

**Example:**  
 Carriage LLRHC 35 A,  
 — a = Preload 0,02 C (T1)  
 — b = Preload 0,08 C (T2)  
 — c = Preload 0,13 C (T3)

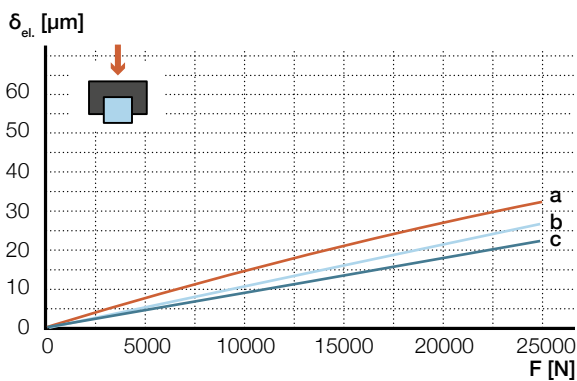

**Example:**  
 Carriage LLRHC 35 LA,  
 — a = Preload 0,02 C (T1)  
 — b = Preload 0,08 C (T2)  
 — c = Preload 0,13 C (T3)

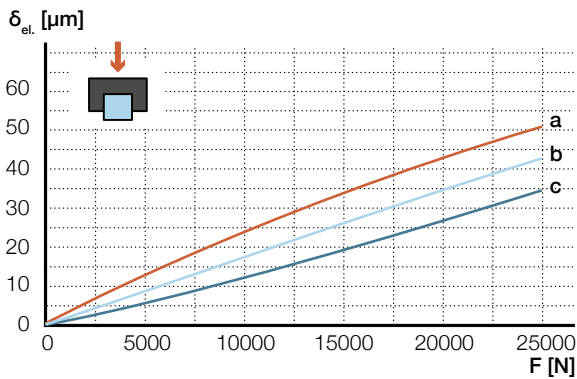

**Example:**  
 Carriage LLRHC 35 U,  
 — a = Preload 0,02 C (T1)  
 — b = Preload 0,08 C (T2)  
 — c = Preload 0,13 C (T3)

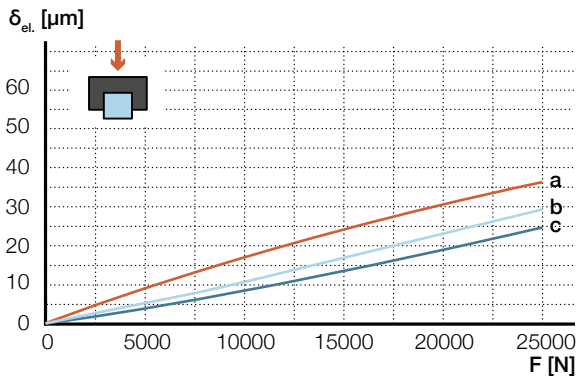

**Example:**  
 Carriage LLRHC 35 LU,  
 — a = Preload 0,02 C (T1)  
 — b = Preload 0,08 C (T2)  
 — c = Preload 0,13 C (T3)

**Legend**

$\delta_{el}$  = elastic deformation  
 F = load



## 2.1.4 Accuracy

### Accuracy classes and their tolerances

Ewellix profile rail guides are available in five accuracy classes. As shown in the adjacent illustration, the tolerances are defined for each accuracy class. The stated accuracy classes are available for almost all types of profile rail guides. For the designs which can be supplied please refer to the respective table on **page 11**.

Dimensional tolerance in height “H”

The dimensional tolerance in height “H” is the maximum deviation of the height “H” for the carriages on a profile rail (**Table 1**).

Dimensional tolerance in width “N”

The dimensional tolerance in width “N” is the maximum deviation of the “N” dimension for the carriages on a profile rail (**Table 1**).

- The “N” dimension designates the distance of the mounting surface of the profile rail from the ground side surface of the carriage.
- The accuracies stated are mean values and relate to the centre of the carriage.

The tolerances should be checked again after the profile rail guide has been mounted on the machine bed.

### Problem-free interchangeability through precision manufacture

The rail and carriage are produced so precisely by Ewellix, especially in the ball raceway area, that each individual element can be exchanged at any time. For example, a carriage can be used without any problems on different rails of the same size. Conversely, various carriages can be used on one rail.

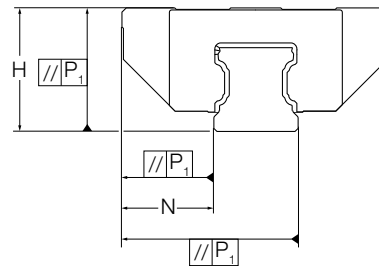
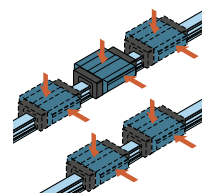
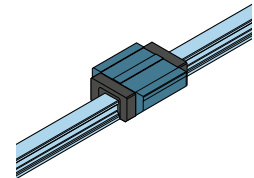

Table 1

Precision class <sup>1)</sup>	Tolerances		Differences in dimension H and N on one rail	
	H	N	ΔH max.	ΔN max.
–	μm		μm	
P5	±100	±40	30	30
P3	±40	±20	15	15
P1	±20	±10	7	7
P01	±10	±7	5	5
P001	±5	±5	3	3



For any combination of carriages and rails over the entire rail length



For different carriages on the same rail position

<sup>1)</sup> Measured at the centre of the carriage

Diagram 1

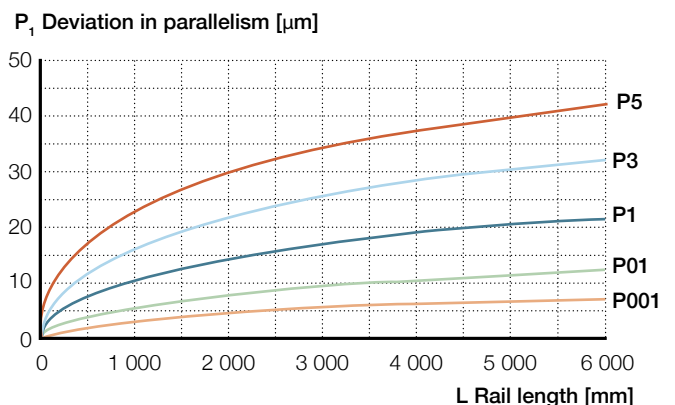

## 2.1.5 Selection criteria for combination of accuracy classes

### Recommendations for the combination of accuracy classes

Recommended for short strokes and small distances between the carriages: Carriage in higher accuracy class than guide rail. Recommended for long strokes and larger distances between the carriages:

Guide rail in higher accuracy class than carriage.

### Running accuracy as selection criterion

By means of perfected ball entry and exit zones in the carriages of accuracy classes P1 and P001, a hitherto unattained running accuracy accompanied by extremely low pulsation is achieved.

This is particularly suitable for ultra-fine metal cutting operations, metrology, high-precision scanners, erosion techniques etc.

Carriage	Rails	P5 µm	P3 µm	P1 µm	P01 µm	P001 µm
P5	Tolerance dimension H (µm)	± 100	± 48	± 32	± 23	± 19
	Tolerance dimension N (µm)	± 40	± 28	± 22	± 20	± 19
	Max. difference of dimensions H and N on a rail (µm)	30	30	30	30	30
P3	Tolerance dimension H (µm)	± 88	± 40	± 23	± 23	± 19
	Tolerance dimension N (µm)	± 33	± 20	± 14	± 20	± 19
	Max. difference of dimensions H and N on a rail (µm)	15	15	15	15	15
P1	Tolerance dimension H (µm)	± 84	± 34	± 21	± 11	± 7
	Tolerance dimension N (µm)	± 28	± 16	± 10	± 8	± 7
	Max. difference of dimensions H and N on a rail (µm)	7	7	7	7	7
P01	Tolerance dimension H (µm)	± 83	± 33	± 19	± 10	± 6
	Tolerance dimension N (µm)	± 27	± 15	± 9	± 7	± 6
	Max. difference of dimensions H and N on a rail (µm)	5	5	5	5	5
P001	Tolerance dimension H (µm)	± 82	± 32	± 18	± 9	± 5
	Tolerance dimension N (µm)	± 26	± 14	± 8	± 6	± 5
	Max. difference of dimensions H and N on a rail (µm)	3	3	3	3	3

# 2.2 Calculation of bearing loads



Fig. 1

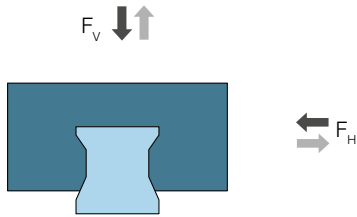

Fig. 2

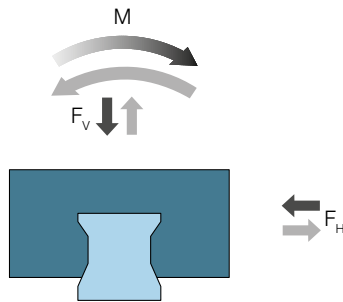
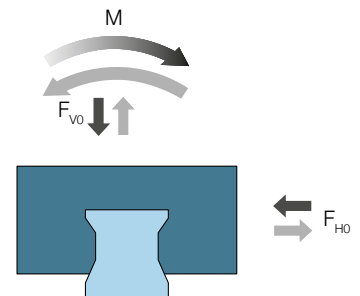

Fig. 3



## Dynamic equivalent bearing load

For a combined external load – vertical and horizontal – the dynamic equivalent load  $F$  is calculated by means of **formula 6**. (→ **fig. 1**)

$$6) F = |F_v| + |F_H|$$

dynamic equivalent load (N)

$F_v$  = dynamic external load, vertical (N)

$F_H$  = dynamic external load, horizontal (N)

**NOTE:** The design of the ball rail guide permits this simplified calculation.

**NOTE:** If different load stages exist for  $F_v$  and  $F_H$ ,  $F_v$  and  $F_H$  must be calculated individually using **formula 5**. An external load applied at any angle to the carriage must be divided into the proportions  $F_v$  and  $F_H$ . The amounts are then used in **formula 6**.

## Dynamic equivalent bearing load

For a combined external load – vertical and horizontal – in combination with a torsional moment the dynamic equivalent load  $F$  can be calculated using **formula 7**. (→ **fig. 2**)

$$7) F = |F_v| + |F_H| + C \times \frac{|M|}{M_t}$$

$F$  = dynamic equivalent load (N)

$F_v, F_H$  = dynamic external loads (N)

$M$  = dynamic torsional moment (Nm)

$C$  = basic dynamic load rating (N)

$M_t$  = dynamic permissible moment (Nm)

**Formula 7** only applies if a single rail is used.

**NOTE:** If different load stages exist for  $F_v$  and  $F_H$ ,  $F_v$  and  $F_H$  must be calculated individually using **formula 5**. An external load applied at any angle to the carriage must be divided into the proportions  $F_v$  and  $F_H$ . The amounts are then used in **formula 7**.

## Static equivalent bearing load

For a combined external static load – vertical and horizontal – in connection with a static torsional moment the static equivalent load  $F_0$  can be calculated using **formula 8**. The static equivalent load  $F_0$  must not exceed the static load rating  $C_0$ .

**Formula 8** only applies if a single rail is used. (→ **fig. 3**)

$$8) F_0 = |F_{v0}| + |F_{H0}| + C_0 \times \frac{|M_0|}{M_{t0}}$$

$F_0$  = static equivalent load (N)

$F_{v0}, F_{H0}$  = static external loads (N)

$M_0$  = static torsional moment (Nm)

$C_0$  = basic static load rating (N)

$M_{t0}$  = static permissible

**NOTE:** An external load applied at any angle to the carriage must be divided into the proportions  $F_{v0}$  and  $F_{H0}$ . The amounts are then used in **formula 8**.

3

Product range



# 3.1 Carriage data

## LLRHC ... SA

Flange short. Standard height



Size design	Ball chain	No ball chain	Ball chain	No ball chain
	C (N)	C (N)	C <sub>0</sub> (N)	C <sub>0</sub> (N)
15	5 900	6 800	6 700	8 100
20	12 400	12 400	13 600	13 600
25	14 000	15 800	15 200	18 200
30	22 100	22 100	24 800	24 800
35	29 300	29 300	32 400	32 400
45	–	–	–	–

## LLRHC ... A

Flange normal. Standard height.



Size design	Ball chain	No ball chain	Ball chain	No ball chain
	C (N)	C (N)	C <sub>0</sub> (N)	C <sub>0</sub> (N)
15	7 280	7 800	12 100	13 500
20	17 400	18 800	21 700	24 400
25	21 300	22 800	27 300	30 400
30	29 300	31 700	37 200	41 300
35	41 900	41 900	54 000	54 000
45	63 300	68 100	77 100	85 700

## LLRHC ... LA

Flange long. Standard height.



Size design	Ball chain	No ball chain	Ball chain	No ball chain
	C (N)	C (N)	C <sub>0</sub> (N)	C <sub>0</sub> (N)
15	9 000	10 000	17 500	20 200
20	23 100	24 400	32 500	35 200
25	27 500	30 400	39 500	45 500
30	38 000	40 000	53 700	57 800
35	53 000	55 600	75 600	81 000
45	81 900	90 400	111 400	128 500

### LLRHC ... SU

Slim line short. Standard height.



Size design	Ball chain	No ball chain	Ball chain	No ball chain
	C (N)	C (N)	C <sub>0</sub> (N)	C <sub>0</sub> (N)
15	5 900	6 800	6 700	8 100
20	12 400	12 400	13 600	13 600
25	14 000	15 800	15 200	18 200
30	22 100	22 100	24 800	24 800
35	29 300	29 300	32 400	32 400
45	-	-	-	-

### LLRHC ... U

Slim line normal. Standard height



Size design	Ball chain	No ball chain	Ball chain	No ball chain
	C (N)	C (N)	C <sub>0</sub> (N)	C <sub>0</sub> (N)
15	7 280	7 800	12 100	13 500
20	17 400	18 800	21 700	24 400
25	21 300	22 800	27 300	30 400
30	29 300	31 700	37 200	41 300
35	41 900	41 900	54 000	54 000
45	63 300	68 100	77 100	85 700

### LLRHC ... LU

Slim line long. Standard height.



Size design	Ball chain	No ball chain	Ball chain	No ball chain
	C (N)	C (N)	C <sub>0</sub> (N)	C <sub>0</sub> (N)
15	9 000	10 000	17 500	20 200
20	23 100	24 400	32 500	35 200
25	27 500	30 400	39 500	45 500
30	38 000	40 000	53 700	57 800
35	53 000	55 600	75 600	81 000
45	81 900	90 400	111 400	128 500

**LLRHC ... R**

Slim line normal. High.



Size design	Ball chain	No ball chain	Ball chain	No ball chain
	C (N)	C (N)	C <sub>0</sub> (N)	C <sub>0</sub> (N)
15	7 280	7 800	12 100	13 500
25	21 300	22 800	27 300	30 400
30	29 300	31 700	37 200	41 300
35	41 900	41 900	54 000	54 000
45	63 300	68 100	77 100	85 700

**LLRHC ... LR**

Slim line long. High.



Size design	Ball chain	No ball chain	Ball chain	No ball chain
	C (N)	C (N)	C <sub>0</sub> (N)	C <sub>0</sub> (N)
25	27 500	30 400	39 500	45 500
30	38 000	40 000	53 700	57 800
35	53 000	55 600	75 600	81 000
45	81 900	90 400	111 400	128 500

**Note on dynamic load capacities and moments**

Determination of dynamic load capacities and moments is based on a travel life of 100 000 m. However, frequently this is determined on the basis of only 50 000 m. In this case for comparison: multiply values C, M<sub>C</sub> and M<sub>A</sub> by 1.26 in accordance with Ewellix tables. For carriages with ball chain the permissible moments are reduced in accordance with the load ratings.

### 3.1.1 Carriage LLRHC ... SA

Flange short. Standard height.

For type designation see designation system

**Dynamic values**

Speed  $v_{max} = 5 \text{ m/s}$

Acceleration  $a_{max} = 500 \text{ m/s}^2$



**Technical data**

Size	Accuracy class		
		T0	T1
15	P5	LLRHC 15 SA T0 P5	LLRHC 15 SA T1 P5
	P3	LLRHC 15 SA T0 P3	LLRHC 15 SA T1 P3
20	P5	LLRHC 20 SA T0 P5	LLRHC 20 SA T1 P5
	P3	LLRHC 20 SA T0 P3	LLRHC 20 SA T1 P3
25	P5	LLRHC 25 SA T0 P5	LLRHC 25 SA T1 P5
	P3	LLRHC 25 SA T0 P3	LLRHC 25 SA T1 P3
30	P5	LLRHC 30 SA T0 P5	LLRHC 30 SA T1 P5
	P3	LLRHC 30 SA T0 P3	LLRHC 30 SA T1 P3
35	P5	LLRHC 35 SA T0 P5	LLRHC 35 SA T1 P5
	P3	LLRHC 35 SA T0 P3	LLRHC 35 SA T1 P3



Dimensional drawing

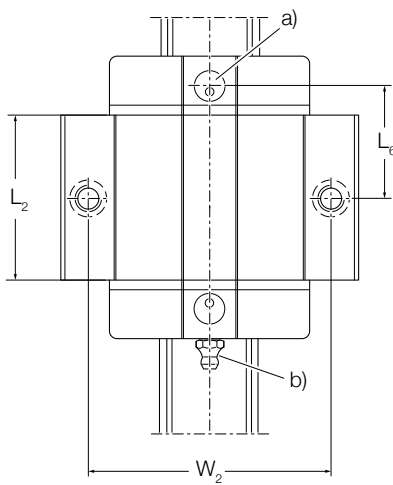
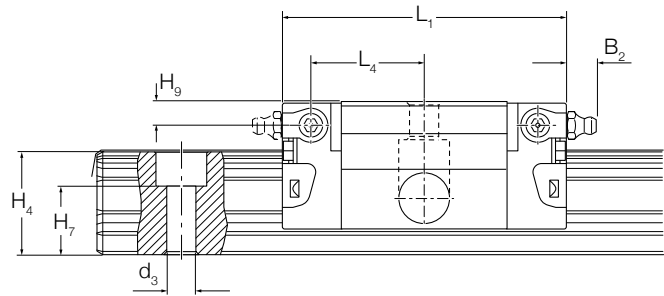
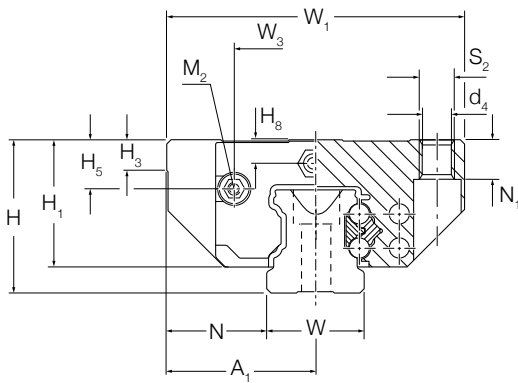

a) For O-ring

- Size 15: Ø 4 x 1,0 (mm)
- Size 20-35: Ø 5 x 1,0 (mm)
- Open lubrication hole as required.
- See additional elements:
- Mounting of lubrication adapter.

b) Lubrication nipple size 15 and 20: Funnel-type nipple

- Type A – Thread size M3 x 5, DIN 3405
- B2 = 1,6 mm
- When using other nipples, the max. permissible screw depth of 5 mm must be observed!
- Size 25 to 35: M6 x 8, DIN 71412
- B2 = 9,5 mm
- When using other nipples, the max. permissible screw depth of 8 mm must be observed!
- Lubrication nipple supplied along with the rail guide (unmounted).
- Connection possible at all sides.
- If pin holes are needed, please refer to section "Mounting instructions".



Size	Dimensions (mm)																	
	W <sub>1</sub>	A <sub>1</sub>	W	N	L <sub>1</sub>	L <sub>2</sub>	H	H <sub>1</sub>	H <sub>4</sub> <sup>1)</sup>	H <sub>4</sub> <sup>2)</sup>	H <sub>3</sub>	W <sub>2</sub>	W <sub>3</sub>	H <sub>5</sub>	L <sub>6</sub>	L <sub>4</sub>	H <sub>8</sub>	H <sub>9</sub>
15	47	23,5	15	16,0	44,7	25,7	24	19,90	16,30	16,20	5,0	38	24,55	6,70	16,25	17,85	3,20	3,20
20	63	31,5	20	21,5	57,3	31,9	30	25,35	20,75	20,55	6,0	53	32,50	7,30	22,95	22,95	3,35	3,35
25	70	35,0	23	23,5	67,0	38,6	36	29,90	24,45	24,25	7,5	57	38,30	11,50	25,35	26,50	5,50	5,50
30	90	45,0	28	31,0	75,3	45,0	42	35,35	28,55	28,35	7,0	72	48,40	14,60	28,80	30,50	6,05	6,05
35	100	50,0	34	33,0	84,9	51,4	48	40,40	32,15	31,85	8,0	82	58,00	17,35	32,70	34,20	6,90	6,90 <sup>1)</sup>

<sup>1)</sup> Dimension H<sub>4</sub> with cover strip

<sup>2)</sup> Dimension H<sub>4</sub> without cover strip

Size	Dimensions (mm)						Weight (kg)	Load ratings (N)		Moments (Nm)			
	N <sub>1</sub>	H <sub>7</sub> <sup>±0,5</sup>	d <sub>4</sub>	S <sub>2</sub>	d <sub>3</sub>	M <sub>2</sub>		C dynamic	C <sub>0</sub> static	M <sub>C</sub> dynamic	M <sub>C0</sub> static	M <sub>A</sub> dynamic	M <sub>B</sub> static
15	5,2	10,3	4,3	M5	4,4	M2,5-3,5 depth	0,15	5 400	8 100	52	80	19	28
20	7,7	13,2	5,3	M6	6,0	M3-5 depth	0,3	12 400	13 600	150	170	52	58
25	9,3	15,2	6,7	M8	7,0	M3-5 depth	0,5	15 900	18 200	230	260	82	94
30	11,0	17,0	8,5	M10	9,0	M3-5 depth	0,8	22 100	24 800	380	430	133	150
35	12,0	20,5	8,5	M10	9,0	M3-5 depth	1,2	29 300	32 400	640	700	200	220

### 3.1.2 Carriage LLRHC ... A

Flange normal. Standard height.

For type designation see designation system

**Dynamic values**

Speed  $v_{max} = 5 \text{ m/s}$

Acceleration  $a_{max} = 500 \text{ m/s}^2$



**Technical data**

Size	Accuracy class	Accuracy class			
		T0	T1	T2	T3
15	P5	<b>LLRHC 15 A T0 P5</b>	<b>LLRHC 15 A T1 P5</b>	LLRHC 15 A T2 P5	
	P3	<b>LLRHC 15 A T0 P3</b>	<b>LLRHC 15 A T1 P3</b>	LLRHC 15 A T2 P3	
	P1		LLRHC 15 A T1 P1	LLRHC 15 A T2 P1	LLRHC 15 A T3 P1
	P01		LLRHC 15 A T1 P01	LLRHC 15 A T2 P01	LLRHC 15 A T3 P01
	P001		LLRHC 15 A T1 P001	LLRHC 15 A T2 P001	LLRHC 15 A T3 P001
20	P5	<b>LLRHC 20 A T0 P5</b>	<b>LLRHC 20 A T1 P5</b>	LLRHC 20 A T2 P5	
	P3	<b>LLRHC 20 A T0 P3</b>	<b>LLRHC 20 A T1 P3</b>	LLRHC 20 A T2 P3	
	P1		LLRHC 20 A T1 P1	LLRHC 20 A T2 P1	LLRHC 20 A T3 P1
	P01		LLRHC 20 A T1 P01	LLRHC 20 A T2 P01	LLRHC 20 A T3 P01
	P001		LLRHC 20 A T1 P001	LLRHC 20 A T2 P001	LLRHC 20 A T3 P001
25	P5	<b>LLRHC 25 A T0 P5</b>	<b>LLRHC 25 A T1 P5</b>	LLRHC 25 A T2 P5	
	P3	<b>LLRHC 25 A T0 P3</b>	<b>LLRHC 25 A T1 P3</b>	LLRHC 25 A T2 P3	
	P1		LLRHC 25 A T1 P1	LLRHC 25 A T2 P1	LLRHC 25 A T3 P1
	P01		LLRHC 25 A T1 P01	LLRHC 25 A T2 P01	LLRHC 25 A T3 P01
	P001		LLRHC 25 A T1 P001	LLRHC 25 A T2 P001	LLRHC 25 A T3 P001
30	P5	<b>LLRHC 30 A T0 P5</b>	<b>LLRHC 30 A T1 P5</b>	LLRHC 30 A T2 P5	
	P3	<b>LLRHC 30 A T0 P3</b>	<b>LLRHC 30 A T1 P3</b>	LLRHC 30 A T2 P3	
	P1		LLRHC 30 A T1 P1	LLRHC 30 A T2 P1	LLRHC 30 A T3 P1
	P01		LLRHC 30 A T1 P01	LLRHC 30 A T2 P01	LLRHC 30 A T3 P01
	P001		LLRHC 30 A T1 P001	LLRHC 30 A T2 P001	LLRHC 30 A T3 P001
35	P5	<b>LLRHC 35 A T0 P5</b>	LLRHC 35 A T1 P5	LLRHC 35 A T2 P5	
	P3	<b>LLRHC 35 A T0 P3</b>	LLRHC 35 A T1 P3	LLRHC 35 A T2 P3	
	P1		LLRHC 35 A T1 P1	LLRHC 35 A T2 P1	LLRHC 35 A T3 P1
	P01		LLRHC 35 A T1 P01	LLRHC 35 A T2 P01	LLRHC 35 A T3 P01
	P001		LLRHC 35 A T1 P001	LLRHC 35 A T2 P001	LLRHC 35 A T3 P001
45	P5	<b>LLRHC 45 A T0 P5</b>	<b>LLRHC 45 A T1 P5</b>	LLRHC 45 A T2 P5	
	P3	<b>LLRHC 45 A T0 P3</b>	<b>LLRHC 45 A T1 P3</b>	LLRHC 45 A T2 P3	
	P1		LLRHC 45 A T1 P1	LLRHC 45 A T2 P1	LLRHC 45 A T3 P1
	P01		LLRHC 45 A T1 P01	LLRHC 45 A T2 P01	LLRHC 45 A T3 P01
	P001		LLRHC 45 A T1 P001	LLRHC 45 A T2 P001	LLRHC 45 A T3 P001

■ Standard range

Dimensional drawing

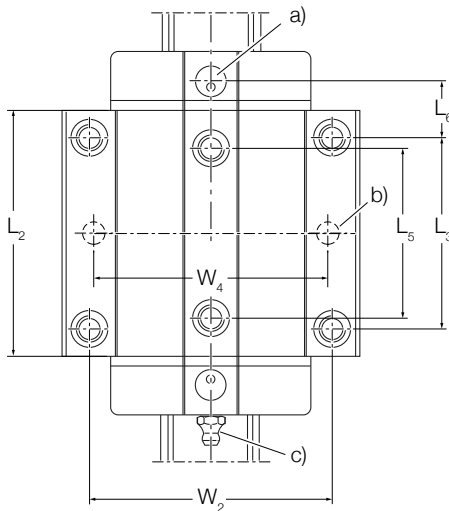
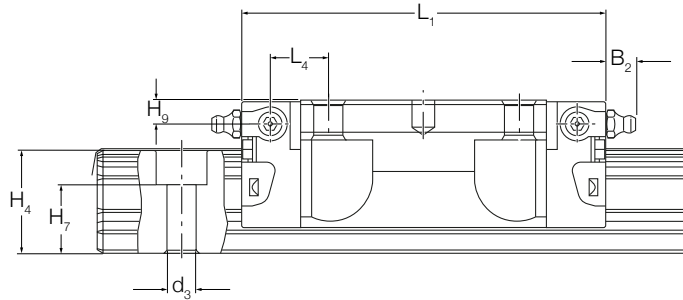
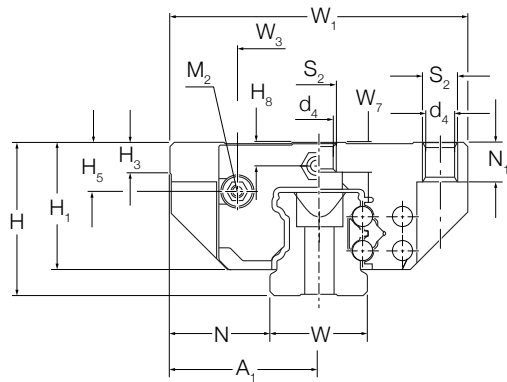

a) For O-ring

Size 15: Ø 4 x 1,0 (mm)

Size 20-35: Ø 5 x 1,0 (mm)

Open lubrication hole as required.

See additional elements: Mounting of lubrication adapter.

b) Recommended position for pin holes (dimensions W4, see "Mounting instructions")

NB: For production-related reasons there may be pilot drill holes in the middle of the carriage. They are suitable for drilling.

c) Lubrication nipple size 15 and 20: Funnel-type nipple

Type A – Thread size M3 x 5, DIN 3405

B2 = 1,6 mm

When using other nipples, the max. permissible screw depth of 5 mm must be observed!

Size 25 to 45: M6 x 8, DIN 71412

B2 = 9,5 mm

When using other lubrication nipples, the max. permissible screw depth of 8 mm must be observed!

Lubrication nipple supplied with the rail guide (unmounted).

Connection possible at all sides.



Size Dimensions (mm)

Size	W <sub>1</sub>	A <sub>1</sub>	W	N	L <sub>1</sub>	L <sub>2</sub>	H	H <sub>1</sub>	H <sub>4</sub> <sup>1)</sup>	H <sub>4</sub> <sup>2)</sup>	H <sub>3</sub>	W <sub>2</sub>	L <sub>3</sub>	L <sub>5</sub>	W <sub>3</sub>	H <sub>5</sub>	L <sub>6</sub>	L <sub>4</sub>	H <sub>8</sub>	H <sub>9</sub>
15	47	23,5	15	16	58	39	24	19,90	16,30	16,20	5,0	38	30	26	24,55	6,70	8,00	9,60	8,00	9,60
20	63	31,5	20	22	75	50	30	25,35	20,75	20,55	6,0	53	40	35	32,50	7,30	11,80	11,80	11,80	11,80
25	70	35,0	23	24	86	58	36	29,90	24,45	24,25	7,5	57	45	40	38,30	11,50	12,45	13,60	12,45	13,60
30	90	45,0	28	31	98	67	42	35,35	28,55	28,35	7,0	72	52	44	48,40	14,60	14,00	15,70	14,00	15,70
35	100	50,0	34	33	111	77	48	40,40	32,15	31,85	8,0	82	62	52	58,00	17,35	14,50	16,00	14,50	16,00
45	120	60,0	45	38	138	97	60	50,30	40,15	39,85	10,0	100	80	60	69,80	20,90	17,30	19,30	17,30	19,30

<sup>1)</sup> Dimension H<sub>4</sub> with cover strip

<sup>2)</sup> Dimension H<sub>4</sub> without cover strip

Size Dimensions (mm)

Weight

Load ratings (N)

Moments (Nm)

Size	Dimensions (mm)							Weight (kg)	Load ratings (N)		Moments (Nm)			
	N <sub>1</sub>	W <sub>7</sub> <sup>±0,5</sup>	H <sub>7</sub> <sup>±0,5</sup>	d <sub>4</sub>	S <sub>2</sub>	d <sub>3</sub>	M <sub>2</sub>		C dynamic	C <sub>0</sub> static	M <sub>C</sub> dynamic	M <sub>C0</sub> static	M <sub>A</sub> dynamic	M <sub>B</sub> static
15	5,2	4,4	10,3	4,3	M5	4,4	M2,5-3,5 depth	0,20	7 800	13 500	74	130	40	71
20	7,7	5,2	13,2	5,3	M6	6	M3-5 depth	0,45	18 800	24 400	240	310	130	165
25	9,3	7,0	15,2	6,7	M8	7	M3-5 depth	0,65	22 800	30 400	320	430	180	240
30	11,0	7,9	17,0	8,5	M10	9	M3-5 depth	1,10	31 700	41 300	540	720	290	380
35	12,0	10,2	20,5	8,5	M10	9	M3-5 depth	1,60	41 900	54 000	890	1 160	440	565
45	15,0	14,4	23,5	10,4	M12	14	M4-7 depth	3,00	68 100	85 700	1 830	2 310	890	1 130

### 3.1.3 Carriage LLRHC ... LA

Flange long. Standard height.

For type designation see designation system

**Dynamic values**

Speed  $v_{max} = 5 \text{ m/s}$

Acceleration  $a_{max} = 500 \text{ m/s}^2$



**Technical data**

Size	Accuracy class	Accuracy class			
		T0	T1	T2	T3
15	P5	<b>LLRHC 15 LA T0 P5</b>	<b>LLRHC 15 LA T1 P5</b>	LLRHC 15 LA T2 P5	
	P3	<b>LLRHC 15 LA T0 P3</b>	<b>LLRHC 15 LA T1 P3</b>	LLRHC 15 LA T2 P3	
	P1		LLRHC 15 LA T1 P1	LLRHC 15 LA T2 P1	LLRHC 15 LA T3 P1
	P01		LLRHC 15 LA T1 P01	LLRHC 15 LA T2 P01	LLRHC 15 LA T3 P01
	P001		LLRHC 15 LA T1 P001	LLRHC 15 LA T2 P001	LLRHC 15 LA T3 P001
20	P5	<b>LLRHC 20 LA T0 P5</b>	<b>LLRHC 20 LA T1 P5</b>	LLRHC 20 LA T2 P5	
	P3	<b>LLRHC 20 LA T0 P3</b>	<b>LLRHC 20 LA T1 P3</b>	LLRHC 20 LA T2 P3	
	P1		LLRHC 20 LA T1 P1	LLRHC 20 LA T2 P1	LLRHC 20 LA T3 P1
	P01		LLRHC 20 LA T1 P01	LLRHC 20 LA T2 P01	LLRHC 20 LA T3 P01
	P001		LLRHC 20 LA T1 P001	LLRHC 20 LA T2 P001	LLRHC 20 LA T3 P001
25	P5	<b>LLRHC 25 LA T0 P5</b>	<b>LLRHC 25 LA T1 P5</b>	LLRHC 25 LA T2 P5	
	P3	<b>LLRHC 25 LA T0 P3</b>	<b>LLRHC 25 LA T1 P3</b>	LLRHC 25 LA T2 P3	
	P1		LLRHC 25 LA T1 P1	LLRHC 25 LA T2 P1	LLRHC 25 LA T3 P1
	P01		LLRHC 25 LA T1 P01	LLRHC 25 LA T2 P01	LLRHC 25 LA T3 P01
	P001		LLRHC 25 LA T1 P001	LLRHC 25 LA T2 P001	LLRHC 25 LA T3 P001
30	P5	<b>LLRHC 30 LA T0 P5</b>	<b>LLRHC 30 LA T1 P5</b>	LLRHC 30 LA T2 P5	
	P3	<b>LLRHC 30 LA T0 P3</b>	<b>LLRHC 30 LA T1 P3</b>	LLRHC 30 LA T2 P3	
	P1		LLRHC 30 LA T1 P1	LLRHC 30 LA T2 P1	LLRHC 30 LA T3 P1
	P01		LLRHC 30 LA T1 P01	LLRHC 30 LA T2 P01	LLRHC 30 LA T3 P01
	P001		LLRHC 30 LA T1 P001	LLRHC 30 LA T2 P001	LLRHC 30 LA T3 P001
35	P5	<b>LLRHC 35 LA T0 P5</b>	LLRHC 35 LA T1 P5	LLRHC 35 LA T2 P5	
	P3	<b>LLRHC 35 LA T0 P3</b>	LLRHC 35 LA T1 P3	LLRHC 35 LA T2 P3	
	P1		LLRHC 35 LA T1 P1	LLRHC 35 LA T2 P1	LLRHC 35 LA T3 P1
	P01		LLRHC 35 LA T1 P01	LLRHC 35 LA T2 P01	LLRHC 35 LA T3 P01
	P001		LLRHC 35 LA T1 P001	LLRHC 35 LA T2 P001	LLRHC 35 LA T3 P001
45	P5	<b>LLRHC 45 LA T0 P5</b>	<b>LLRHC 45 LA T1 P5</b>	LLRHC 45 LA T2 P5	
	P3	<b>LLRHC 45 LA T0 P3</b>	<b>LLRHC 45 LA T1 P3</b>	LLRHC 45 LA T2 P3	
	P1		LLRHC 45 LA T1 P1	LLRHC 45 LA T2 P1	LLRHC 45 LA T3 P1
	P01		LLRHC 45 LA T1 P01	LLRHC 45 LA T2 P01	LLRHC 45 LA T3 P01
	P001		LLRHC 45 LA T1 P001	LLRHC 45 LA T2 P001	LLRHC 45 LA T3 P001

■ Standard range

Dimensional drawing

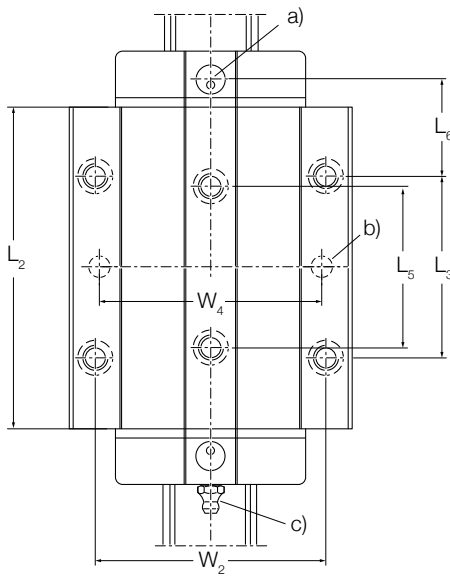
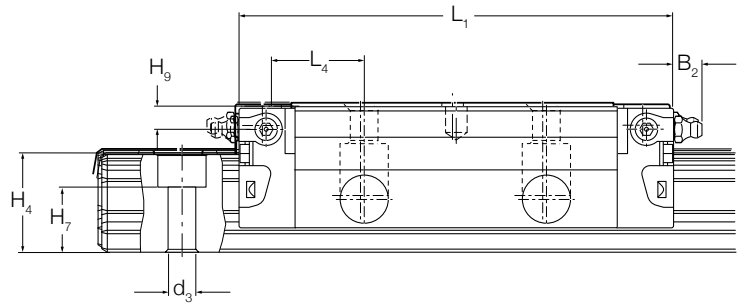
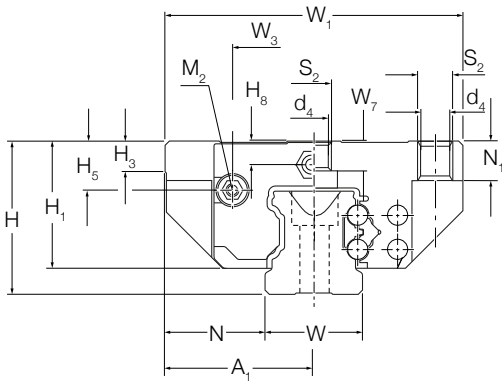

a) For O-ring

- Size 15: Ø 4 x 1,0 (mm)
- Size 20-45: Ø 5 x 1,0 (mm)
- Open lubrication hole as required.

b) Recommended position for pin holes (dimensions W4, see "Mounting instructions")

NB: For production-related reasons there may be pilot drill holes in the middle of the carriage. They are suitable for drilling.

c) Lubrication nipple size 15 and 20: Funnel-type nipple Type A – Thread size M3 x 5, DIN 3405 B2 = 1.6 mm

When using other nipples, the max. permissible screw depth of 5 mm must be observed!

Size 25 to 45: M6 x 8, DIN 71412

B<sub>2</sub> = 9.5 mm

When using other lubrication nipples, the max. permissible screw depth of 8 mm must be observed!

Lubrication nipple supplied with the rail guide (unmounted).  
Connection possible at all sides.

Size	Dimensions (mm)																			
	W <sub>1</sub>	A <sub>1</sub>	W	N	L <sub>1</sub>	L <sub>2</sub>	H	H <sub>1</sub>	H <sub>4</sub> <sup>1)</sup>	H <sub>4</sub> <sup>2)</sup>	H <sub>3</sub>	W <sub>2</sub>	L <sub>3</sub>	L <sub>5</sub>	W <sub>3</sub>	H <sub>5</sub>	L <sub>6</sub>	L <sub>4</sub>	H <sub>8</sub>	H <sub>9</sub>
15	47	23,5	15	16,0	72,6	53,6	24	19,90	16,30	16,20	5,0	38	30	26	24,55	6,70	15,20	16,80	3,20	3,20
20	63	31,5	20	21,5	91,0	65,6	30	25,35	20,75	20,55	6,0	53	40	35	32,50	7,30	19,80	19,80	3,35	3,35
25	70	35,0	23	23,5	107,9	79,5	36	29,90	24,45	24,25	7,5	57	45	40	38,30	11,50	23,30	24,45	5,50	5,50
30	90	45,0	28	31,0	119,7	89,4	42	35,35	28,55	28,35	7,0	72	52	44	48,40	14,60	25,00	26,70	6,05	6,05
35	100	50,0	34	33,0	139,0	105,5	48	40,40	32,15	31,85	8,0	82	62	52	58,00	17,35	28,75	30,25	6,90	6,90
45	120	60,0	45	37,5	174,1	133,5	60	50,30	40,15	39,85	10,0	100	80	60	69,80	20,90	35,50	37,50	8,20	8,20

<sup>1)</sup> Dimension H<sub>4</sub> with cover strip  
<sup>2)</sup> Dimension H<sub>4</sub> without cover strip

Size	Dimensions (mm)							Weight (kg)	Load ratings (N)		Moments (Nm)			
	N <sub>1</sub>	W <sub>7</sub> ±0,5	H <sub>7</sub> ±0,5	d <sub>4</sub>	S <sub>2</sub>	d <sub>3</sub>	M <sub>2</sub>		C dynamic	C <sub>0</sub> static	M <sub>C</sub> dynamic	M <sub>C0</sub> static	M <sub>A</sub> dynamic	M <sub>B</sub> static
15	5,2	4,4	10,3	4,3	M5	4,4	M2,5-3,5 depth	0,30	10 000	20 200	130	190	98	150
20	7,7	5,2	13,2	5,3	M6	6	M3-5 depth	0,55	24 400	35 200	310	450	225	330
25	9,3	7,0	15,2	6,7	M8	7	M3-5 depth	0,90	30 400	45 500	430	650	345	510
30	11,0	7,9	17,0	8,5	M10	9	M3-5 depth	1,50	40 000	57 800	690	1 000	495	715
35	12,0	10,2	20,5	8,5	M10	9	M3-5 depth	2,25	55 600	81 000	1 200	1 740	830	1 215
45	15,0	12,4	23,5	10,4	M12	14	M4-7 depth	4,30	90 400	128 500	2 440	3 470	1 700	2 425



### 3.1.4 Carriage LLRHC ... SU

Slim line short. Standard height.  
For type designation see designation system

**Dynamic values**

Speed  $v_{max} = 5 \text{ m/s}$

Acceleration  $a_{max} = 500 \text{ m/s}^2$



**Technical data**

Size	Accuracy class		
		T0	T1
15	P5	LLRHC 15 SU T0 P5	LLRHC 15 SU T1 P5
	P3	LLRHC 15 SU T0 P3	LLRHC 15 SU T1 P3
	P1	LLRHC 15 SU T0 P1	LLRHC 15 SU T1 P1
20	P5	LLRHC 20 SU T0 P5	LLRHC 20 SU T1 P5
	P3	LLRHC 20 SU T0 P3	LLRHC 20 SU T1 P3
	P1	LLRHC 20 SU T0 P1	LLRHC 20 SU T1 P1
25	P5	LLRHC 25 SU T0 P5	LLRHC 25 SU T1 P5
	P3	LLRHC 25 SU T0 P3	LLRHC 25 SU T1 P3
	P1	LLRHC 25 SU T0 P1	LLRHC 25 SU T1 P1
30	P5	LLRHC 30 SU T0 P5	LLRHC 30 SU T1 P5
	P3	LLRHC 30 SU T0 P3	LLRHC 30 SU T1 P3
	P1	LLRHC 30 SU T0 P1	LLRHC 30 SU T1 P1
35	P5	LLRHC 35 SU T0 P5	LLRHC 35 SU T1 P5
	P3	LLRHC 35 SU T0 P3	LLRHC 35 SU T1 P3
	P1	LLRHC 35 SU T0 P1	LLRHC 35 SU T1 P1

■ Standard range

Dimensional drawing

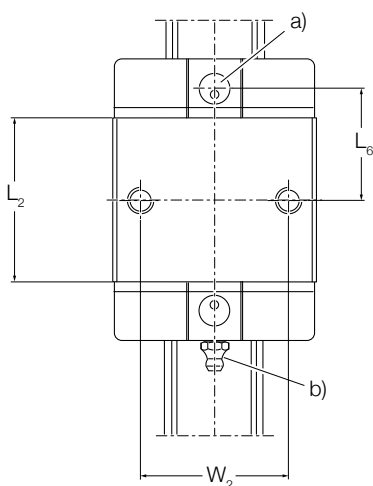
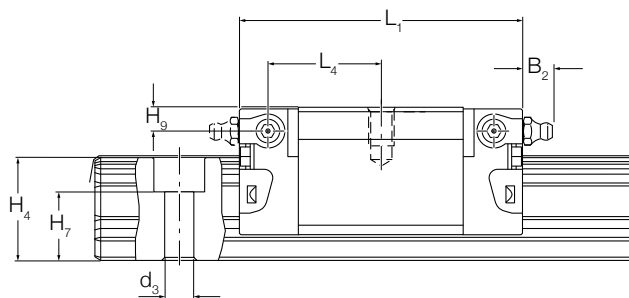
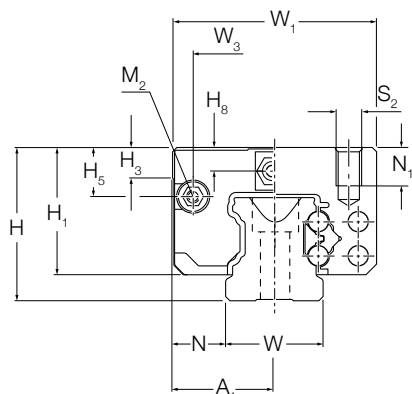

- a) For O-ring  
 Size 15: Ø 4 x 1,0 (mm)  
 Size 20-35: Ø 5 x 1,0 (mm)  
 Open lubrication hole as required.
- b) Lubrication nipple size 15 and 20: Funnel-type nipple  
 Type A – Thread size M3 x 5, DIN 3405  
 B2 = 1,6 mm  
 When using other nipples, the max. permissible screw depth of 5 mm must be observed!
  
- Size 25 to 35:  
 M6 x 8, DIN 71412  
 B2 = 9,5 mm  
 When using other lubrication nipples, the max. permissible screw depth of 8 mm must be observed!  
 Lubrication nipple supplied with the rail guide (unmounted).  
 Connection possible at all sides.  
 If pin holes are needed, please refer to section "Mounting instructions".

Size	Dimensions (mm)																	
	W <sub>1</sub>	A <sub>1</sub>	W	N	L <sub>1</sub>	L <sub>2</sub>	H	H <sub>1</sub>	H <sub>4</sub> <sup>1)</sup>	H <sub>4</sub> <sup>2)</sup>	H <sub>3</sub>	W <sub>2</sub>	W <sub>3</sub>	H <sub>5</sub>	L <sub>6</sub>	L <sub>4</sub>	H <sub>8</sub>	H <sub>9</sub>
15	34	17	15	9,5	44,7	25,7	24	19,90	16,30	16,20	5,0	26	24,55	6,70	16,25	17,85	3,20	3,20
20	44	22	20	12,0	57,3	31,9	30	25,35	20,75	20,55	6,0	32	32,50	7,30	22,95	22,95	3,35	3,35
25	48	24	23	12,5	67,0	38,6	36	29,90	24,45	24,25	7,5	35	38,30	11,50	25,35	26,50	5,50	5,50
30	60	30	28	16,0	75,3	45,0	42	35,35	28,55	28,35	7,0	40	48,40	14,60	28,80	30,50	6,05	6,05
35	70	35	34	18,0	84,9	51,4	48	40,40	32,15	31,85	8,0	50	58,00	17,35	32,70	34,20	6,90	6,90 <sup>1)</sup>

<sup>1)</sup> Dimension H<sub>4</sub> with cover strip  
<sup>2)</sup> Dimension H<sub>4</sub> without cover strip

Size	Dimensions (mm)					Weight (kg)	Load ratings (N)		Moments (Nm)			
	N <sub>1</sub>	H <sub>7</sub> <sup>±0,5</sup>	S <sub>2</sub>	d <sub>3</sub>	M <sub>2</sub>		C dynamic	C <sub>0</sub> static	M <sub>C</sub> dynamic	M <sub>C0</sub> static	M <sub>A</sub> dynamic	M <sub>B</sub> static
15	6,0	10,3	M4	4,4	M2,5-3,5 depth	0,10	5 400	8 100	52	80	19	28
20	7,5	13,2	M5	6,0	M3-5 depth	0,25	12 400	13 600	150	170	52	58
25	9,0	15,2	M6	7,0	M3-5 depth	0,35	15 900	18 200	230	260	82	94
30	12,0	17,0	M8	9,0	M3-5 depth	0,60	22 100	24 800	380	430	133	150
35	13,0	20,5	M8	9,0	M3-5 depth	0,90	29 300	32 400	640	700	200	220

### 3.1.5 Carriage LLRHC ... U

Slim line normal. Standard height.

For type designation see designation system

**Dynamic values**

Speed  $v_{max} = 5 \text{ m/s}$

Acceleration  $a_{max} = 500 \text{ m/s}^2$



**Technical data**

Size	Accuracy class	Accuracy class		
		T0	T1	T2
15	P5	<b>LLRHC 15 U T0 P5</b>	<b>LLRHC 15 U T1 P5</b>	LLRHC 15 U T2 P5
	P3	<b>LLRHC 15 U T0 P3</b>	<b>LLRHC 15 U T1 P3</b>	LLRHC 15 U T2 P3
	P1	LLRHC 15 U T0 P1	LLRHC 15 U T1 P1	LLRHC 15 U T2 P1
20	P5	<b>LLRHC 20 U T0 P5</b>	<b>LLRHC 20 U T1 P5</b>	LLRHC 20 U T2 P5
	P3	<b>LLRHC 20 U T0 P3</b>	<b>LLRHC 20 U T1 P3</b>	LLRHC 20 U T2 P3
	P1	LLRHC 20 U T0 P1	LLRHC 20 U T1 P1	LLRHC 20 U T2 P1
25	P5	<b>LLRHC 25 U T0 P5</b>	<b>LLRHC 25 U T1 P5</b>	LLRHC 25 U T2 P5
	P3	<b>LLRHC 25 U T0 P3</b>	<b>LLRHC 25 U T1 P3</b>	LLRHC 25 U T2 P3
	P1	LLRHC 25 U T0 P1	LLRHC 25 U T1 P1	LLRHC 25 U T2 P1
30	P5	<b>LLRHC 30 U T0 P5</b>	<b>LLRHC 30 U T1 P5</b>	LLRHC 30 U T2 P5
	P3	<b>LLRHC 30 U T0 P3</b>	<b>LLRHC 30 U T1 P3</b>	LLRHC 30 U T2 P3
	P1	LLRHC 30 U T0 P1	LLRHC 30 U T1 P1	LLRHC 30 U T2 P1
35	P5	<b>LLRHC 35 U T0 P5</b>	<b>LLRHC 35 U T1 P5</b>	LLRHC 35 U T2 P5
	P3	<b>LLRHC 35 U T0 P3</b>	<b>LLRHC 35 U T1 P3</b>	LLRHC 35 U T2 P3
	P1	LLRHC 35 U T0 P1	LLRHC 35 U T1 P1	LLRHC 35 U T2 P1
45	P5	<b>LLRHC 45 U T0 P5</b>	<b>LLRHC 45 U T1 P5</b>	LLRHC 45 U T2 P5
	P3	<b>LLRHC 45 U T0 P3</b>	<b>LLRHC 45 U T1 P3</b>	LLRHC 45 U T2 P3
	P1	LLRHC 45 U T0 P1	LLRHC 45 U T1 P1	LLRHC 45 U T2 P1

■ Standard range



Dimensional drawing

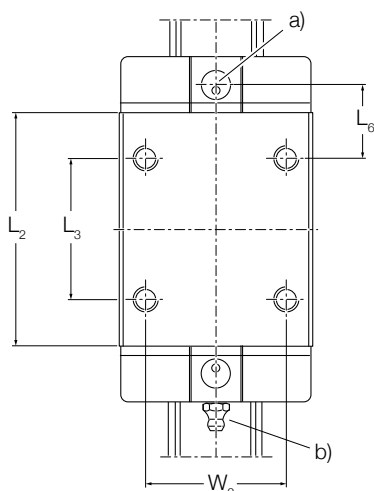
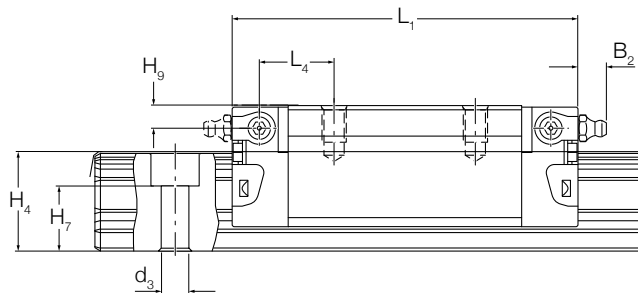
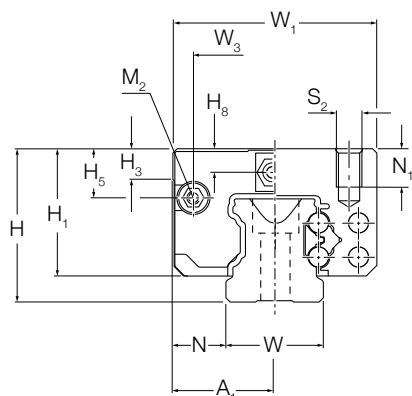

- a) For O-ring  
 Size 15: Ø 4 x 1,0 (mm)  
 Size 20-45: Ø 5 x 1,0 (mm)  
 Open lubrication hole as required.

- b) Lubrication nipple size 15 and 20: Funnel-type nipple  
 Type A – Thread size M3 x 5, DIN 3405  
 B2 = 1,6 mm  
 When using other nipples, the max. permissible screw depth of 5 mm must be observed!

- Size 25 to 45:  
 M6 x 8, DIN 71412  
 B2 = 9,5 mm  
 When using other lubrication nipples, the max. permissible screw depth of 8 mm must be observed!  
 Lubrication nipple supplied with the rail guide (unmounted).  
 Connection possible at all sides.  
 If pin holes are needed, please refer to section "Mounting instructions".

Size	Dimensions (mm)																		
	W <sub>1</sub>	A <sub>1</sub>	W	N	L <sub>1</sub>	L <sub>2</sub>	H	H <sub>1</sub>	H <sub>4</sub> <sup>1)</sup>	H <sub>4</sub> <sup>2)</sup>	H <sub>3</sub>	W <sub>2</sub>	L <sub>3</sub>	W <sub>3</sub>	H <sub>5</sub>	L <sub>6</sub>	L <sub>4</sub>	H <sub>8</sub>	H <sub>9</sub>
15	34	17	15	9,5	58,2	39,2	24	19,90	16,30	16,20	5,0	26	26	24,55	6,70	10,00	11,60	3,20	3,20
20	44	22	20	12,0	75,0	49,6	30	25,35	20,75	20,55	6,0	32	36	32,50	7,30	13,80	13,80	3,35	3,35
25	48	24	23	12,5	86,2	57,8	36	29,90	24,45	24,25	7,5	35	35	38,30	11,50	17,45	18,60	5,50	5,50
30	60	30	28	16,0	97,7	67,4	42	35,35	28,55	28,35	7,0	40	40	48,40	14,60	20,00	21,70	6,05	6,05
35	70	35	34	18,0	110,5	77,0	48	40,40	32,15	31,85	8,0	50	50	58,00	17,35	20,50	22,00	6,90	6,90
45	86	43	45	20,5	137,6	97,0	60	50,30	40,15	39,85	10,0	60	60	69,80	20,90	27,30	29,30	8,20	8,20

<sup>1)</sup> Dimension H<sub>4</sub> with cover strip  
<sup>2)</sup> Dimension H<sub>4</sub> without cover strip

Size	Dimensions (mm)					Weight (kg)	Load ratings (N)		Moments (Nm)			
	N1	H <sub>7</sub> <sup>±0,5</sup>	S <sub>2</sub>	d <sub>3</sub>	M <sub>2</sub>		C dynamic	C <sub>0</sub> static	M <sub>C</sub> dynamic	M <sub>C0</sub> static	M <sub>A</sub> dynamic	M <sub>B</sub> static
15	6,0	10,3	M4	4,4	M2,5-3,5 depth	0,15	7 800	13 500	74	130	40	71
20	7,5	13,2	M5	6,0	M3-5 depth	0,35	18 800	24 400	240	310	130	165
25	9,0	15,2	M6	7,0	M3-5 depth	0,50	22 800	30 400	320	430	180	240
30	12,0	17,0	M8	9,0	M3-5 depth	0,85	31 700	41 300	540	720	290	380
35	13,0	20,5	M8	9,0	M3-5 depth	1,25	41 900	54 000	890	1 160	440	565
45	18,0	23,5	M10	14,0	M4-7 depth	2,40	68 100	85 700	1 830	2 310	890	1 130

### 3.1.6 Carriage LLRHC ... LU

Slim line normal. Standard height.

For type designation see designation system

**Dynamic values**

Speed  $v_{max} = 5 \text{ m/s}$

Acceleration  $a_{max} = 500 \text{ m/s}^2$



**Technical data**

Size	Accuracy class	Accuracy class		
		T0	T1	T2
15	P5	<b>LLRHC 15 LU T0 P5</b>	<b>LLRHC 15 LU T1 P5</b>	LLRHC 15 LU T2 P5
	P3	<b>LLRHC 15 LU T0 P3</b>	<b>LLRHC 15 LU T1 P3</b>	LLRHC 15 LU T2 P3
	P1		LLRHC 15 LU T1 P1	LLRHC 15 LU T2 P1
20	P5	<b>LLRHC 20 LU T0 P5</b>	<b>LLRHC 20 LU T1 P5</b>	LLRHC 20 LU T2 P5
	P3	<b>LLRHC 20 LU T0 P3</b>	<b>LLRHC 20 LU T1 P3</b>	LLRHC 20 LU T2 P3
	P1		LLRHC 20 LU T1 P1	LLRHC 20 LU T2 P1
25	P5	<b>LLRHC 25 LU T0 P5</b>	<b>LLRHC 25 LU T1 P5</b>	LLRHC 25 LU T2 P5
	P3	<b>LLRHC 25 LU T0 P3</b>	<b>LLRHC 25 LU T1 P3</b>	LLRHC 25 LU T2 P3
	P1		LLRHC 25 LU T1 P1	LLRHC 25 LU T2 P1
30	P5	<b>LLRHC 30 LU T0 P5</b>	<b>LLRHC 30 LU T1 P5</b>	LLRHC 30 LU T2 P5
	P3	<b>LLRHC 30 LU T0 P3</b>	<b>LLRHC 30 LU T1 P3</b>	LLRHC 30 LU T2 P3
	P1		LLRHC 30 LU T1 P1	LLRHC 30 LU T2 P1
35	P5	<b>LLRHC 35 LU T0 P5</b>	<b>LLRHC 35 LU T1 P5</b>	LLRHC 35 LU T2 P5
	P3	<b>LLRHC 35 LU T0 P3</b>	<b>LLRHC 35 LU T1 P3</b>	LLRHC 35 LU T2 P3
	P1		LLRHC 35 LU T1 P1	LLRHC 35 LU T2 P1
45	P5	<b>LLRHC 45 LU T0 P5</b>	<b>LLRHC 45 LU T1 P5</b>	LLRHC 45 LU T2 P5
	P3	<b>LLRHC 45 LU T0 P3</b>	<b>LLRHC 45 LU T1 P3</b>	LLRHC 45 LU T2 P3
	P1		LLRHC 45 LU T1 P1	LLRHC 45 LU T2 P1

■ Standard range

Dimensional drawing

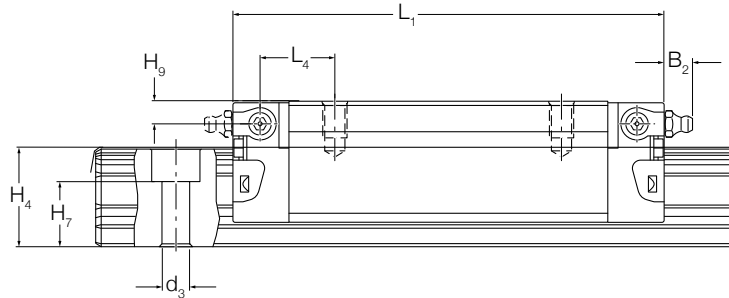
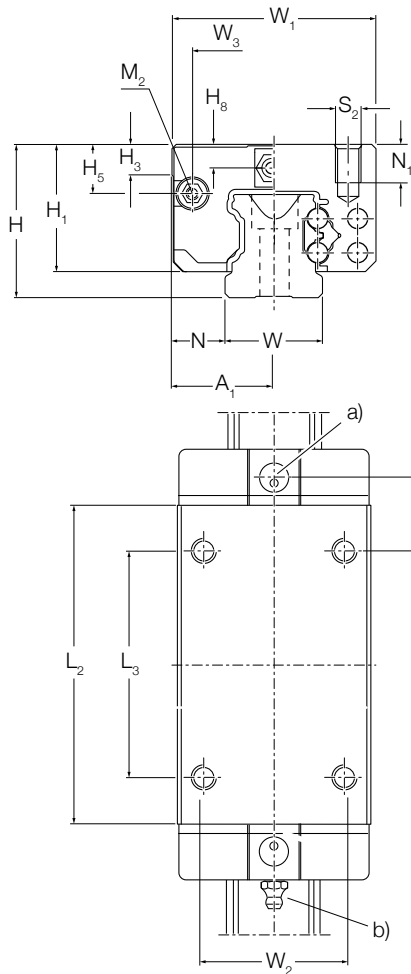

- a) For O-ring  
 Size 15: Ø 4 x 1,0 (mm)  
 Size 20-45: Ø 5 x 1,0 (mm)  
 Open lubrication hole as required.
- b) Lubrication nipple size 15 and 20: Funnel-type nipple  
 Type A – Thread size M3 x 5, DIN 3405  
 B2 = 1,6 mm  
 When using other nipples, the max. permissible screw depth of 5 mm must be observed!
- Size 25 to 45:  
 M6 x 8, DIN 71412  
 B2 = 9,5 mm  
 When using other lubrication nipples, the max. permissible screw depth of 8 mm must be observed!  
 Lubrication nipple supplied with the rail guide (unmounted).  
 Connection possible at all sides.  
 If pin holes are needed, please refer to section "Mounting instructions".

Size	Dimensions (mm)																		
	W <sub>1</sub>	A <sub>1</sub>	W	N	L <sub>1</sub>	L <sub>2</sub>	H	H <sub>1</sub>	H <sub>4</sub> <sup>1)</sup>	H <sub>4</sub> <sup>2)</sup>	H <sub>3</sub>	W <sub>2</sub>	L <sub>3</sub>	W <sub>3</sub>	H <sub>5</sub>	L <sub>6</sub>	L <sub>4</sub>	H <sub>8</sub>	H <sub>9</sub>
15	34	17	15	9,5	72,6	53,6	24	19,90	16,30	16,20	5,0	26	26	24,55	6,70	17,20	18,80	3,20	3,20
20	44	22	20	12,0	91,0	65,6	30	25,35	20,75	20,55	6,0	32	50	32,50	7,30	14,80	14,80	3,35	3,35
25	48	24	23	12,5	107,9	79,5	36	29,90	24,45	24,25	7,5	35	50	38,30	11,50	20,80	21,95	5,50	5,50
30	60	30	28	16,0	119,7	89,4	42	35,35	28,55	28,35	7,0	40	60	48,40	14,60	21,00	22,70	6,05	6,05
35	70	35	34	18,0	139,0	105,5	48	40,40	32,15	31,85	8,0	50	72	58,00	17,35	23,75	25,25	6,90	6,90
45	86	43	45	20,5	174,1	133,5	60	50,30	40,15	39,85	10,0	60	80	69,80	20,90	35,50	37,50	8,20	8,20

<sup>1)</sup> Dimension H<sub>4</sub> with cover strip  
<sup>2)</sup> Dimension H<sub>4</sub> without cover strip

Size	Dimensions (mm)					Weight (kg)	Load ratings (N)		Moments (Nm)		Moments (Nm)	
	N1	H <sub>7</sub> <sup>±0,5</sup>	S <sub>2</sub>	d <sub>3</sub>	M <sub>2</sub>		C dynamic	C <sub>0</sub> static	M <sub>C</sub> dynamic	M <sub>C0</sub> static	M <sub>A</sub> dynamic	M <sub>B</sub> static
15	6,0	10,3	M4	4,4	M2,5-3,5 depth	0,15	7 800	13 500	74	130	40	71
20	7,5	13,2	M5	6,0	M3-5 depth	0,35	18 800	24 400	240	310	130	165
25	9,0	15,2	M6	7,0	M3-5 depth	0,50	22 800	30 400	320	430	180	240
30	12,0	17,0	M8	9,0	M3-5 depth	0,85	31 700	41 300	540	720	290	380
35	13,0	20,5	M8	9,0	M3-5 depth	1,25	41 900	54 000	890	1 160	440	565
45	18,0	23,5	M10	14,0	M4-7 depth	2,40	68 100	85 700	1 830	2 310	890	1 130

### 3.1.7 Carriage LLRHC ... R

Slim line normal. High.

For type designation see designation system

**Dynamic values**

Speed  $v_{max} = 5 \text{ m/s}$

Acceleration  $a_{max} = 500 \text{ m/s}^2$



**Technical data**

Size	Accuracy class	Accuracy class		
		T0	T1	T2
15	P5	<b>LLRHC 15 R T0 P5</b>	<b>LLRHC 15 R T1 P5</b>	LLRHC 15 R T2 P5
	P3	<b>LLRHC 15 R T0 P3</b>	<b>LLRHC 15 R T1 P3</b>	LLRHC 15 R T2 P3
	P1		LLRHC 15 R T1 P1	LLRHC 15 R T2 P1
25	P5	<b>LLRHC 25 R T0 P5</b>	<b>LLRHC 25 R T1 P5</b>	LLRHC 25 R T2 P5
	P3	<b>LLRHC 25 R T0 P3</b>	<b>LLRHC 25 R T1 P3</b>	LLRHC 25 R T2 P3
	P1		LLRHC 25 R T1 P1	LLRHC 25 R T2 P1
30	P5	<b>LLRHC 30 R T0 P5</b>	<b>LLRHC 30 R T1 P5</b>	LLRHC 30 R T2 P5
	P3	<b>LLRHC 30 R T0 P3</b>	<b>LLRHC 30 R T1 P3</b>	LLRHC 30 R T2 P3
	P1		LLRHC 30 R T1 P1	LLRHC 30 R T2 P1
35	P5	<b>LLRHC 35 R T0 P5</b>	<b>LLRHC 35 R T1 P5</b>	LLRHC 35 R T2 P5
	P3	<b>LLRHC 35 R T0 P3</b>	<b>LLRHC 35 R T1 P3</b>	LLRHC 35 R T2 P3
	P1		LLRHC 35 R T1 P1	LLRHC 35 R T2 P1
45	P5	<b>LLRHC 45 R T0 P5</b>	<b>LLRHC 45 R T1 P5</b>	LLRHC 45 R T2 P5
	P3	<b>LLRHC 45 R T0 P3</b>	<b>LLRHC 45 R T1 P3</b>	LLRHC 45 R T2 P3
	P1		LLRHC 45 R T1 P1	LLRHC 45 R T2 P1

■ Standard range

Dimensional drawing

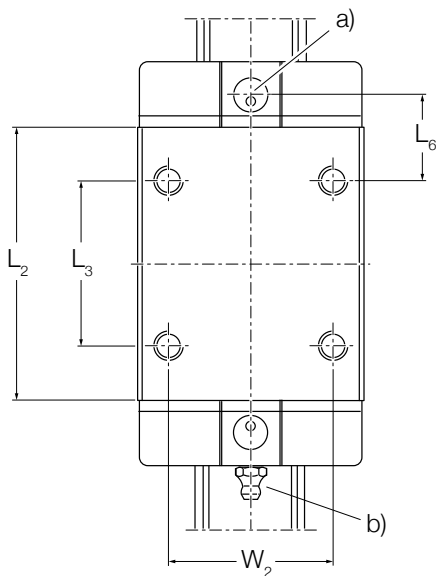
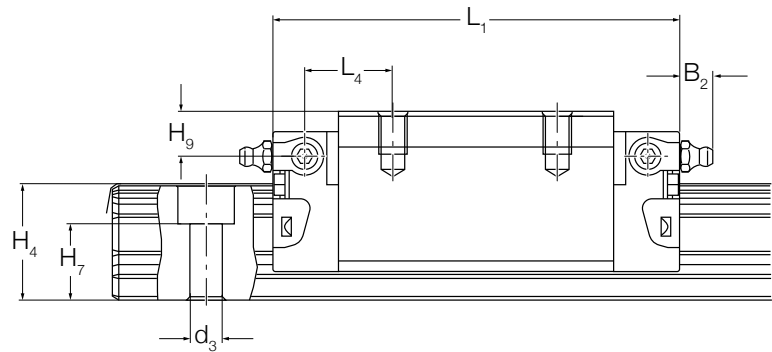
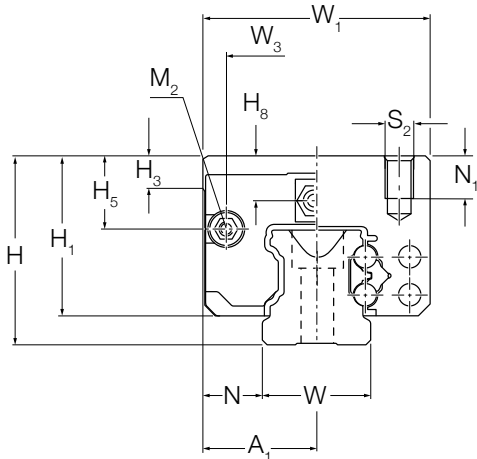

- a) For O-ring  
Size 15: Ø 4 x 1,0 (mm)  
Size 20-45: Ø 5 x 1,0 (mm)  
Open lubrication hole as required.

- b) Lubrication nipple size 15 and 20: Funnel-type nipple  
Type A – Thread size M3 x 5, DIN 3405  
B2 = 1,6 mm  
When using other nipples, the max. permissible screw depth of 5 mm must be observed!

- Size 25 to 45:  
M6 x 8, DIN 71412  
B2 = 9,5 mm  
When using other lubrication nipples, the max. permissible screw depth of 8 mm must be observed!  
Lubrication nipple supplied with the rail guide (unmounted).  
Connection possible at all sides.  
If pin holes are needed, please refer to section "Mounting instructions".

Size Dimensions (mm)

Size	W <sub>1</sub>	A <sub>1</sub>	W	N	L <sub>1</sub>	L <sub>2</sub>	H	H <sub>1</sub>	H <sub>4</sub> <sup>1)</sup>	H <sub>4</sub> <sup>2)</sup>	H <sub>3</sub>	W <sub>2</sub>	L <sub>3</sub>	W <sub>3</sub>	H <sub>5</sub>	L <sub>6</sub>	L <sub>4</sub>	H <sub>8</sub>	H <sub>9</sub>
15	34	17	15	9,5	58,2	39,2	28	23,90	16,30	16,20	5,0	26	26	24,55	10,70	10,00	11,6	7,20	7,20
25	48	24	23	12,5	86,2	57,8	40	33,90	24,45	24,25	7,5	35	35	38,30	15,50	17,45	18,6	9,50	9,50
30	60	30	28	16,0	97,7	67,4	45	38,35	28,55	28,35	7,0	40	40	48,40	17,60	20,00	21,7	9,05	9,05
35	70	35	34	18,0	110,5	77,0	55	47,40	32,15	31,85	8,0	50	50	58,00	24,35	20,50	22,0	13,90	13,90
45	86	43	45	20,5	137,6	97,0	70	60,30	40,15	39,85	10,0	60	60	69,80	30,90	27,30	29,3	18,20	18,20

<sup>1)</sup> Dimension H<sub>4</sub> with cover strip  
<sup>2)</sup> Dimension H<sub>4</sub> without cover strip

Size Dimensions (mm)

Weight

Load ratings (N)

Moments (Nm)

Size	N1	H <sub>7</sub> <sup>±0,5</sup>	S <sub>2</sub>	d <sub>3</sub>	M <sub>2</sub>	Weight (kg)	Load ratings (N)		Moments (Nm)			
							C dynamic	C <sub>0</sub> static	M <sub>C</sub> dynamic	M <sub>C0</sub> static	M <sub>A</sub> dynamic	M <sub>B</sub> static
15	6	10,3	M4	4,4	M2,5-3,5 depth	0,2	7 800	13 500	74	130	40	71
25	9	15,2	M6	7,0	M3-5 depth	0,6	22 800	30 400	320	430	180	240
30	12	17,0	M8	9,0	M3-5 depth	0,95	31 700	41 300	540	720	290	380
35	13	20,5	M8	9,0	M3-5 depth	1,55	41 900	54 000	890	1 160	440	565
45	18	23,5	M10	14,0	M4-7 depth	3	68 100	85 700	1 830	2 310	890	1 130

### 3.1.8 Carriage LLRHC ... LR

Slim line long. High.

For type designation see designation system

**Dynamic values**

Speed  $v_{max} = 5 \text{ m/s}$

Acceleration  $a_{max} = 500 \text{ m/s}^2$



**Technical data**

Size	Accuracy class	Accuracy class		
		T0	T1	T2
25	P5	<b>LLRHC 25 LR T0 P5</b>	<b>LLRHC 25 LR T1 P5</b>	LLRHC 25 LR T2 P5
	P3	<b>LLRHC 25 LR T0 P3</b>	<b>LLRHC 25 LR T1 P3</b>	LLRHC 25 LR T2 P3
	P1		LLRHC 25 LR T1 P1	LLRHC 25 LR T2 P1
30	P5	<b>LLRHC 30 LR T0 P5</b>	<b>LLRHC 30 LR T1 P5</b>	LLRHC 30 LR T2 P5
	P3	<b>LLRHC 30 LR T0 P3</b>	<b>LLRHC 30 LR T1 P3</b>	LLRHC 30 LR T2 P3
	P1		LLRHC 30 LR T1 P1	LLRHC 30 LR T2 P1
35	P5	<b>LLRHC 35 LR T0 P5</b>	<b>LLRHC 35 LR T1 P5</b>	LLRHC 35 LR T2 P5
	P3	<b>LLRHC 35 LR T0 P3</b>	<b>LLRHC 35 LR T1 P3</b>	LLRHC 35 LR T2 P3
	P1		LLRHC 35 LR T1 P1	LLRHC 35 LR T2 P1
45	P5	<b>LLRHC 45 LR T0 P5</b>	<b>LLRHC 45 LR T1 P5</b>	LLRHC 45 LR T2 P5
	P3	<b>LLRHC 45 LR T0 P3</b>	<b>LLRHC 45 LR T1 P3</b>	LLRHC 45 LR T2 P3
	P1		LLRHC 45 LR T1 P1	LLRHC 45 LR T2 P1

■ Standard range

Dimensional drawing

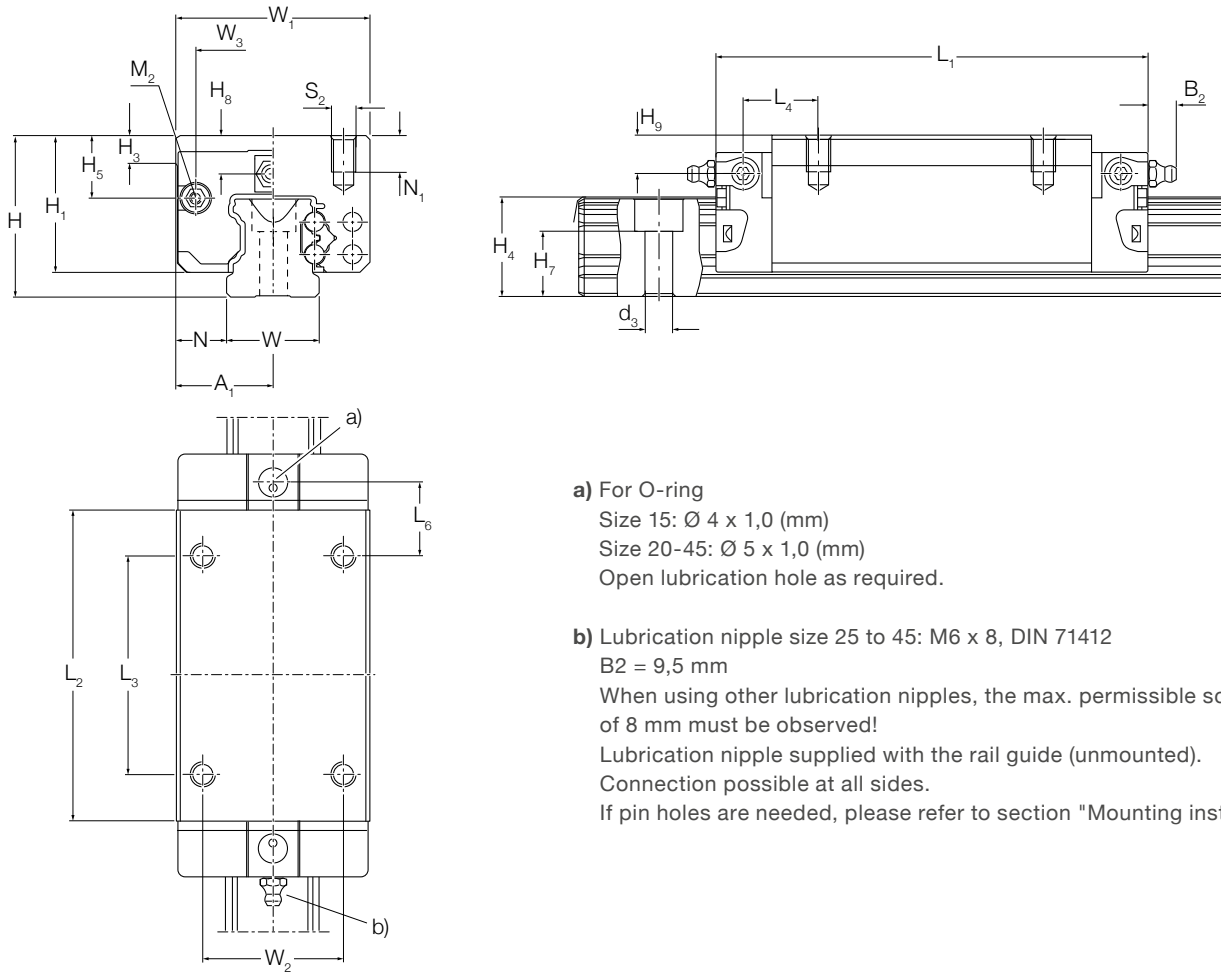

- a) For O-ring  
 Size 15: Ø 4 x 1,0 (mm)  
 Size 20-45: Ø 5 x 1,0 (mm)  
 Open lubrication hole as required.
- b) Lubrication nipple size 25 to 45: M6 x 8, DIN 71412  
 B2 = 9,5 mm  
 When using other lubrication nipples, the max. permissible screw depth of 8 mm must be observed!  
 Lubrication nipple supplied with the rail guide (unmounted).  
 Connection possible at all sides.  
 If pin holes are needed, please refer to section "Mounting instructions".



Size	Dimensions (mm)																		
	W <sub>1</sub>	A <sub>1</sub>	W	N	L <sub>1</sub>	L <sub>2</sub>	H	H <sub>1</sub>	H <sub>4</sub> <sup>1)</sup>	H <sub>4</sub> <sup>2)</sup>	H <sub>3</sub>	W <sub>2</sub>	L <sub>3</sub>	W <sub>3</sub>	H <sub>5</sub>	L <sub>6</sub>	L <sub>4</sub>	H <sub>8</sub>	H <sub>9</sub>
25	48	24	23	12,5	107,9	79,5	40	33,90	24,45	24,25	7,5	35	50	38,3	15,50	20,80	21,95	9,50	9,50
30	60	30	28	16	119,7	89,4	45	38,35	28,55	28,35	7,0	40	60	48,4	17,60	21,00	22,70	9,05	9,05
35	70	35	34	18	139,0	105,5	55	47,40	32,15	31,85	8,0	50	72	58,0	24,35	23,75	25,25	13,90	13,90
45	86	43	45	20,5	174,1	133,5	70	60,30	40,15	39,85	10,0	60	80	69,8	30,90	35,50	37,50	18,20	18,20

<sup>1)</sup> Dimension H<sub>4</sub> with cover strip  
<sup>2)</sup> Dimension H<sub>4</sub> without cover strip

Size	Dimensions (mm)					Weight (kg)	Load ratings (N)		Moments (Nm)			
	N1	H <sub>7</sub> ±0,5	S <sub>2</sub>	d <sub>3</sub>	M <sub>2</sub>		C dynamic	C <sub>0</sub> static	M <sub>C</sub> dynamic	M <sub>C0</sub> static	M <sub>A</sub> dynamic	M <sub>B</sub> static
25	9	15,2	M6	7	M3-5 depth	0,8	30 400	45 500	430	650	345	510
30	12	17,0	M8	9	M3-5 depth	1,2	40 000	57 800	690	1 000	495	715
35	13	20,5	M8	9	M3-5 depth	2,1	55 600	81 000	1 200	1 740	830	1 215
45	18	23,5	M10	14	M4-7 depth	4,1	90 400	128 500	2 440	3 470	1 700	2 425

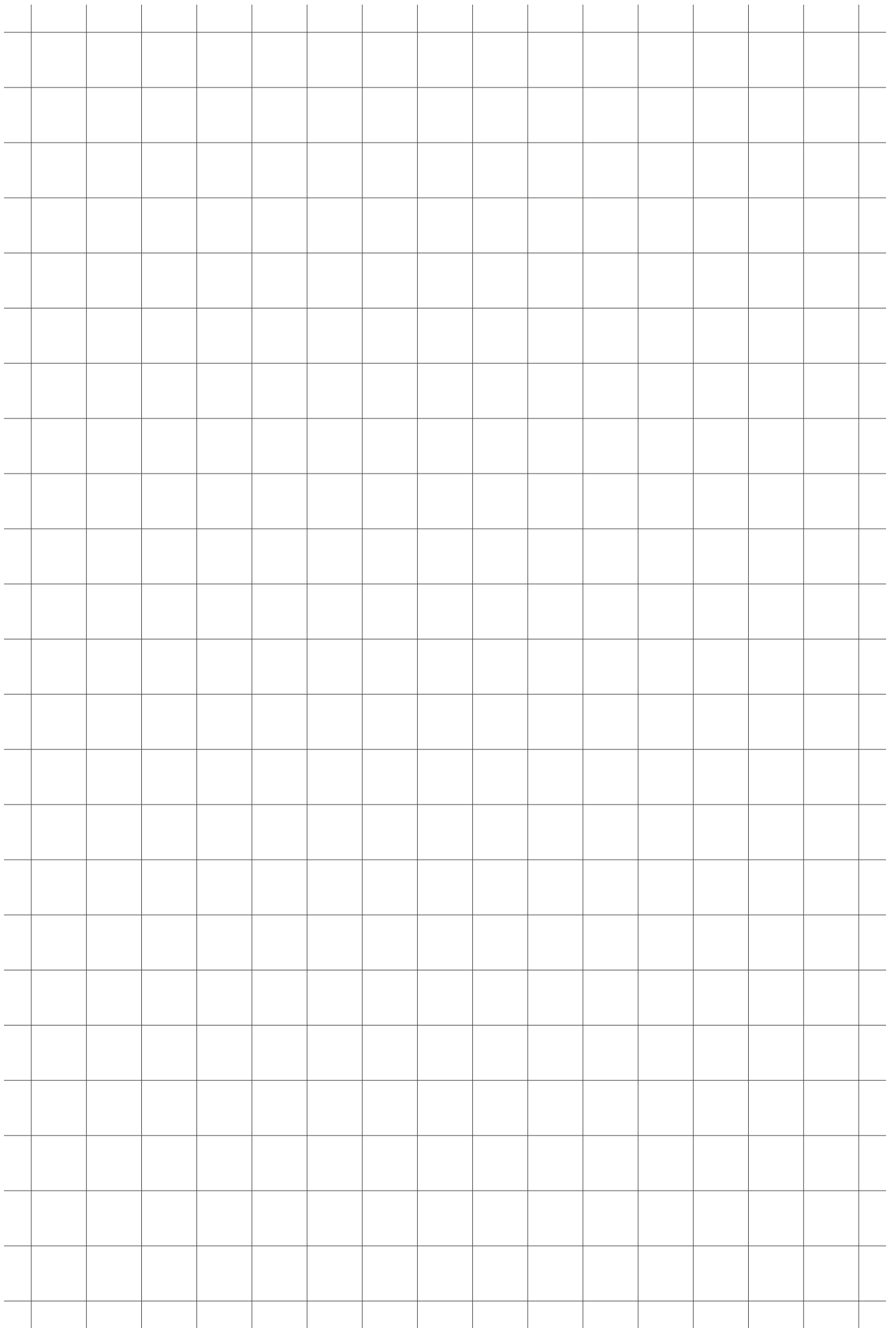



## 3.2 Rail data

*Rails with protective caps made of plastics*

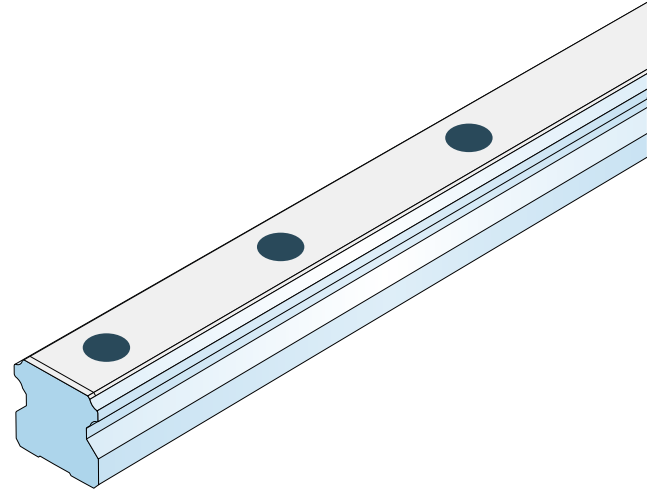

*Rails with cover strip and cover strip retaining clamps made of aluminium - without end face threaded holes (not required)*

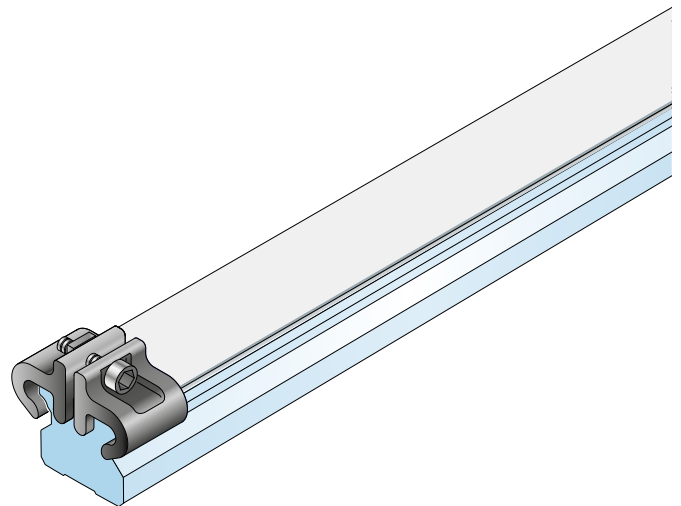

### 3.2.1 LLRHR rails

For mounting from above with plastic mounting caps (supplied).

**NOTE:** The rails can also be supplied in several parts.

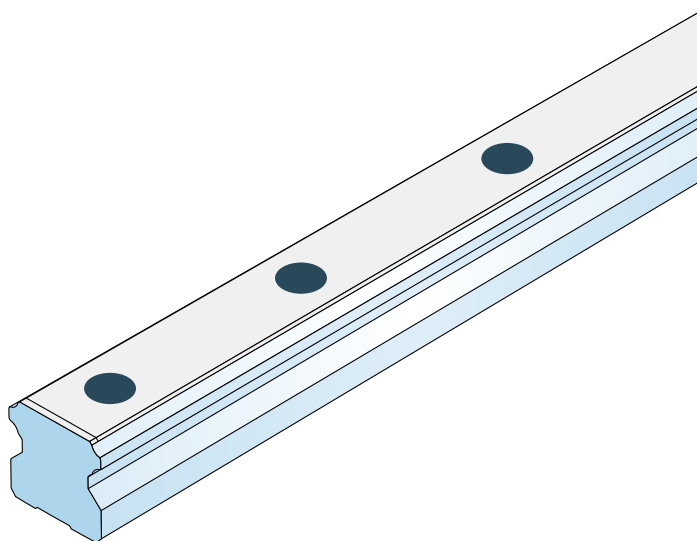

#### Technical data

Standard rail		Rail one-piece	Rail multi-piece	Pitch T
Size	Accuracy	Designation	Designation	[mm]
15	<b>P5</b>	<b>LLRHR 15 - xxxx P5</b>	<b>LLRHR 15 - xxxx P5 A</b>	60
	<b>P3</b>	<b>LLRHR 15 - xxxx P3</b>	<b>LLRHR 15 - xxxx P3 A</b>	
	P1	LLRHR 15 - xxxx P1	LLRHR 15 - xxxx P1 A	
	P01	LLRHR 15 - xxxx P01	LLRHR 15 - xxxx P01 A	
	P001	LLRHR 15 - xxxx P001	LLRHR 15 - xxxx P001 A	
20	<b>P5</b>	<b>LLRHR 20 - xxxx P5</b>	<b>LLRHR 20 - xxxx P5 A</b>	60
	<b>P3</b>	<b>LLRHR 20 - xxxx P3</b>	<b>LLRHR 20 - xxxx P3 A</b>	
	P1	LLRHR 20 - xxxx P1	LLRHR 20 - xxxx P1 A	
	P01	LLRHR 20 - xxxx P01	LLRHR 20 - xxxx P01 A	
	P001	LLRHR 20 - xxxx P001	LLRHR 20 - xxxx P001 A	
25	<b>P5</b>	<b>LLRHR 25 - xxxx P5</b>	<b>LLRHR 25 - xxxx P5 A</b>	60
	<b>P3</b>	<b>LLRHR 25 - xxxx P3</b>	<b>LLRHR 25 - xxxx P3 A</b>	
	P1	LLRHR 25 - xxxx P1	LLRHR 25 - xxxx P1 A	
	P01	LLRHR 25 - xxxx P01	LLRHR 25 - xxxx P01 A	
	P001	LLRHR 25 - xxxx P001	LLRHR 25 - xxxx P001 A	
30	<b>P5</b>	<b>LLRHR 30 - xxxx P5</b>	<b>LLRHR 30 - xxxx P5 A</b>	80
	<b>P3</b>	<b>LLRHR 30 - xxxx P3</b>	<b>LLRHR 30 - xxxx P3 A</b>	
	P1	LLRHR 30 - xxxx P1	LLRHR 30 - xxxx P1 A	
	P01	LLRHR 30 - xxxx P01	LLRHR 30 - xxxx P01 A	
	P001	LLRHR 30 - xxxx P001	LLRHR 30 - xxxx P001 A	
35	<b>P5</b>	<b>LLRHR 35 - xxxx P5</b>	<b>LLRHR 35 - xxxx P5 A</b>	80
	<b>P3</b>	<b>LLRHR 35 - xxxx P3</b>	<b>LLRHR 35 - xxxx P3 A</b>	
	P1	LLRHR 35 - xxxx P1	LLRHR 35 - xxxx P1 A	
	P01	LLRHR 35 - xxxx P01	LLRHR 35 - xxxx P01 A	
	P001	LLRHR 35 - xxxx P001	LLRHR 35 - xxxx P001 A	
45	P5	LLRHR 45 - xxxx P5	LLRHR 45 - xxxx P5 A	105
	P3	LLRHR 45 - xxxx P3	LLRHR 45 - xxxx P3 A	
	P1	LLRHR 45 - xxxx P1	LLRHR 45 - xxxx P1 A	
	P01	LLRHR 45 - xxxx P01	LLRHR 45 - xxxx P01 A	
	P001	LLRHR 45 - xxxx P001	LLRHR 45 - xxxx P001 A	

■ Standard range  
xxxx = rail length

Dimensional drawing

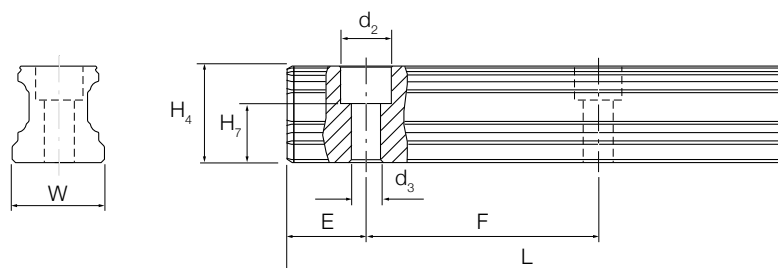

Size	Dimensions (mm)								Weight kg/m
	W <sub>1</sub>	H <sub>4</sub>	H <sub>7</sub> <sup>±0,5</sup>	d <sub>2</sub>	d <sub>3</sub>	E <sub>1 min</sub>	F	L <sub>max</sub>	
15	15	16,2	10,3	7,4	4,4	10	60	4 000	1,4
20	20	20,55	13,2	9,4	6,0	10	60	4 000	2,4
25	23	24,25	15,2	11,0	7,0	10	60	4 000	3,2
30	28	28,35	17,0	15,0	9,0	12	80	4 000	5,0
35	34	31,85	20,5	15,0	9,0	12	80	4 000	6,8
45	45	39,85	23,5	20,0	14,0	16	105	4 000	10,5

<sup>1</sup> Dimension H<sub>4</sub> with cover strip

<sup>2</sup> Dimension H<sub>7</sub> without cover strip

The “E” dimension designates the distance from the rail end to the centre of the first attachment hole.

If no customer-specific “E” dimension is provided with the order, the rails are produced according to the following formula: The distance of the first and last attachment holes is mediated.

If several possibilities arise, the shorter “E” dimension will be produced!

$$E = \frac{L - (z - 1) \times F}{2}$$

- E = Rail end dimension
- F = Distance of attachment holes
- L = Rail length
- z = Number of attachment holes

### 3.2.2 LLRHR D2 rails

For mounting from above with cover strip and strip retaining clamps.

- Robust cover strip retaining clamps made of aluminium
- Rail without end face threaded holes (not required for cover strip retaining clamps)

**NOTE:** The rails can also be supplied in several parts.

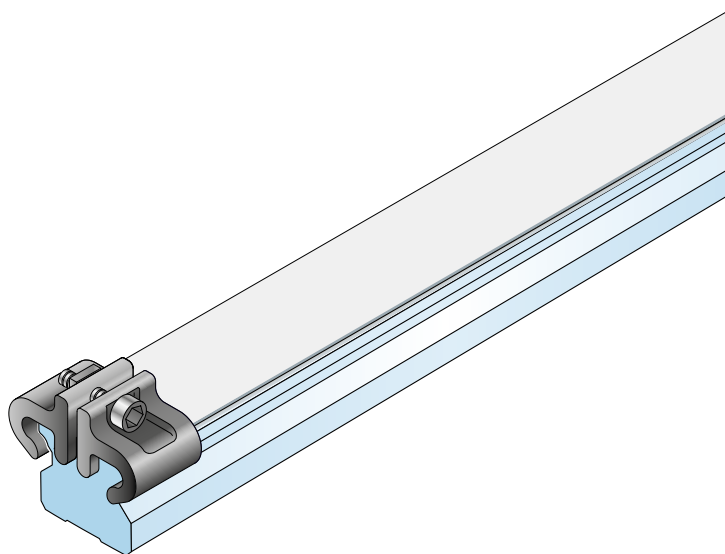

#### Technical data

Standard rail		Rail one-piece	Rail multi-piece	Pitch
Size	Accuracy	Designation	Designation	[mm]
15	<b>P5 D2</b>	<b>LLRHR 15 - xxxx P5 D2</b>	<b>LLRHR 15 - xxxx P5 A D2</b>	60
	<b>P3 D2</b>	<b>LLRHR 15 - xxxx P3 D2</b>	<b>LLRHR 15 - xxxx P3 A D2</b>	
	P1 D2	LLRHR 15 - xxxx P1 D2	LLRHR 15 - xxxx P1 A D2	
	P01 D2	LLRHR 15 - xxxx P01 D2	LLRHR 15 - xxxx P01 A D2	
	P001 D2	LLRHR 15 - xxxx P001 D2	LLRHR 15 - xxxx P001 A D2	
20	<b>P5 D2</b>	<b>LLRHR 20 - xxxx P5 D2</b>	<b>LLRHR 20 - xxxx P5 A D2</b>	60
	<b>P3 D2</b>	<b>LLRHR 20 - xxxx P3 D2</b>	<b>LLRHR 20 - xxxx P3 A D2</b>	
	P1 D2	LLRHR 20 - xxxx P1 D2	LLRHR 20 - xxxx P1 A D2	
	P01 D2	LLRHR 20 - xxxx P01 D2	LLRHR 20 - xxxx P01 A D2	
	P001 D2	LLRHR 20 - xxxx P001 D2	LLRHR 20 - xxxx P001 A D2	
25	<b>P5 D2</b>	<b>LLRHR 25 - xxxx P5 D2</b>	<b>LLRHR 25 - xxxx P5 A D2</b>	60
	<b>P3 D2</b>	<b>LLRHR 25 - xxxx P3 D2</b>	<b>LLRHR 25 - xxxx P3 A D2</b>	
	P1 D2	LLRHR 25 - xxxx P1 D2	LLRHR 25 - xxxx P1 A D2	
	P01 D2	LLRHR 25 - xxxx P01 D2	LLRHR 25 - xxxx P01 A D2	
	P001	LLRHR 25 - xxxx P001 D2	LLRHR 25 - xxxx P001 A D2	
30	<b>P5 D2</b>	<b>LLRHR 30 - xxxx P5 D2</b>	<b>LLRHR 30 - xxxx P5 A D2</b>	80
	<b>P3 D2</b>	<b>LLRHR 30 - xxxx P3 D2</b>	<b>LLRHR 30 - xxxx P3 A D2</b>	
	P1 D2	LLRHR 30 - xxxx P1 D2	LLRHR 30 - xxxx P1 A D2	
	P01 D2	LLRHR 30 - xxxx P01 D2	LLRHR 30 - xxxx P01 A D2	
	P001 D2	LLRHR 30 - xxxx P001 D2	LLRHR 30 - xxxx P001 A D2	
35	<b>P5 D2</b>	<b>LLRHR 35 - xxxx P5 D2</b>	<b>LLRHR 35 - xxxx P5 A D2</b>	80
	<b>P3 D2</b>	<b>LLRHR 35 - xxxx P3 D2</b>	<b>LLRHR 35 - xxxx P3 A D2</b>	
	P1 D2	LLRHR 35 - xxxx P1 D2	LLRHR 35 - xxxx P1 A D2	
	P01 D2	LLRHR 35 - xxxx P01 D2	LLRHR 35 - xxxx P01 A D2	
	P001 D2	LLRHR 35 - xxxx P001 D2	LLRHR 35 - xxxx P001 A D2	
45	<b>P5 D2</b>	<b>LLRHR 45 - xxxx P5 D2</b>	<b>LLRHR 45 - xxxx P5 A D2</b>	105
	<b>P3 D2</b>	<b>LLRHR 45 - xxxx P3 D2</b>	<b>LLRHR 45 - xxxx P3 A D2</b>	
	P1 D2	LLRHR 45 - xxxx P1 D2	LLRHR 45 - xxxx P1 A D2	
	P01 D2	LLRHR 45 - xxxx P01 D2	LLRHR 45 - xxxx P01 A D2	
	P001 D2	LLRHR 45 - xxxx P001 D2	LLRHR 45 - xxxx P001 A D2	

■ Standard range  
xxxx = rail length

Dimensional drawing

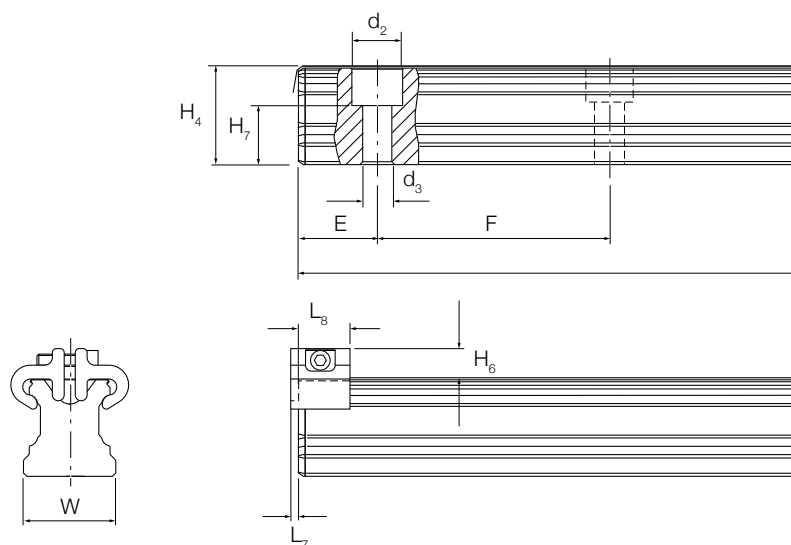

Size	Dimensions (mm)											Weight kg/m
	W <sub>1</sub>	H <sub>4</sub>	H <sub>7</sub>	H <sub>6</sub>	L <sub>8</sub>	L <sub>7</sub>	d <sub>2</sub>	d <sub>3</sub>	E <sub>1 min</sub>	F	L <sub>max</sub>	
15	15	16,30	10,3	7,3	12	2,0	7,4	4,4	10	60	3 000	1,4
20	20	20,75	13,2	7,1	12	2,0	9,4	6,0	10	60	4 000	2,4
25	23	24,45	15,2	8,2	13	2,0	11,0	7,0	10	60	4 000	3,2
30	28	28,50	17,0	8,7	13	2,0	15,0	9,0	12	80	4 000	5,0
35	34	32,15	20,5	11,7	16	2,2	15,0	9,0	12	80	4 000	6,8
45	45	40,15	23,5	12,5	18	2,2	20,0	14,0	16	105	4 000	10,5

<sup>1</sup> Dimension H<sub>4</sub> with cover strip

<sup>2</sup> Dimension H<sub>4</sub> without cover strip

The “E” dimension designates the distance from the rail end to the centre of the first attachment hole.

If no customer-specific “E” dimension is provided with the order, the rails are produced according to the following formula: The distance of the first and last attachment holes is mediated.

If several possibilities arise, the shorter “E” dimension will be produced!

$$E = \frac{L - (z - 1) \times F}{2}$$

- E = Rail end dimension
- F = Distance of attachment holes
- L = Rail length
- z = Number of attachment holes

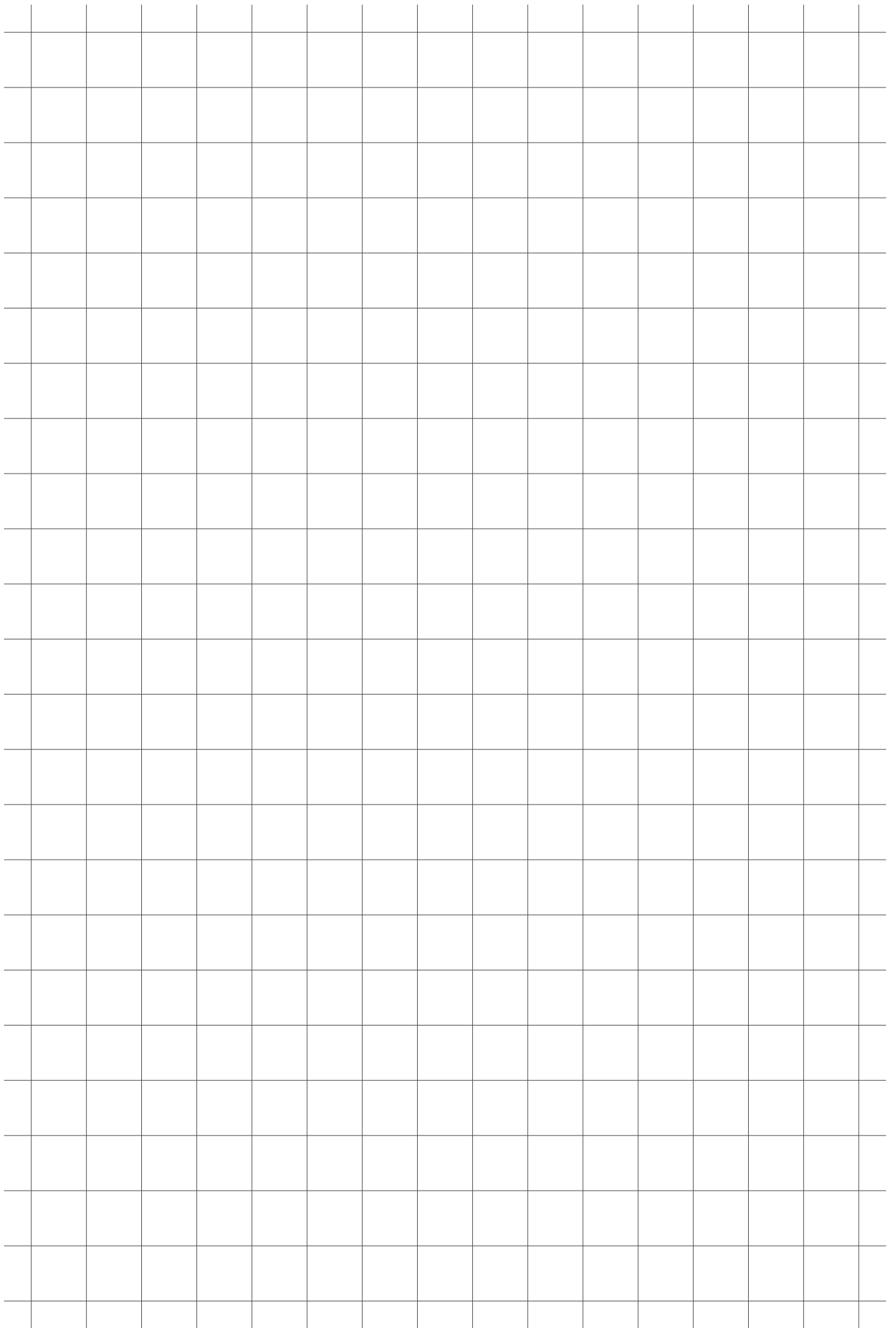

# 3.3 Accessories

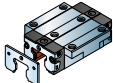
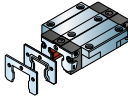
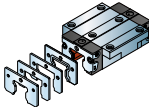
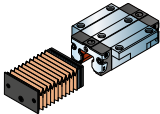
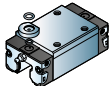
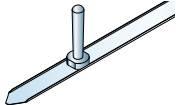
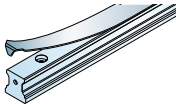
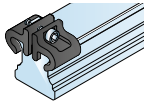
Accessories		
Item name	Illustration <sup>1)</sup>	Purpose
Scraper plate		Scraper plates are spring-steel, non-contact components. They protect the front seal from coarse contaminants or hot metal chips.
Two-piece front seal		Additional front seals are contact seals that can be attached to the carriage end faces. They are singlelip seals consisting of special heavy-duty material and offer additional protection against liquids and smaller contaminants.
Sealing kit		The seal kit consists of a metal scraper and an additional front seal. It is intended for applications involving exposure to coarse and fine dirt as well as liquids.
Bellows		Bellows protect the entire system against solid and liquid contaminants from above. They are suitable for highly contaminated environments like machining centres in the woodworking and metals industries.
Lubrication adapter		
Expanding mandrel		
Loose cover strip		
Cover strip retaining clamps made of aluminium		

<sup>1)</sup> Appearance can vary slightly depending on the size

### 3.3.1 Scraper plate

**Material:**

stainless spring steel to DIN EN 10088

- Condition: bright
- Precision design with 0,2 to 0,3 mm maximum gap measurement

**Mounting:**

Fastening screws are supplied. During mounting please ensure an even gap between the rail and scraper plate. Scraper plate for rails with and without cover strip

**NOTE:** Use in combination with two-piece front seal kit LLRHZxxS3.

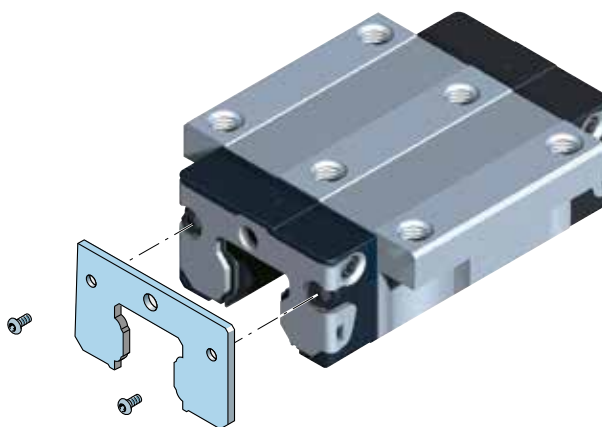

**Dimensional drawing**

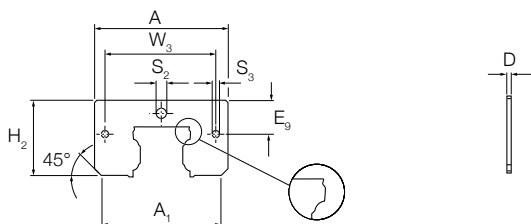

**Technical data**

Size	Part numbers	Dimensions (mm)								Weight (g)
		A	A <sub>1</sub>	H <sub>2</sub>	W <sub>3</sub>	E <sub>9</sub>	S <sub>2</sub>	S <sub>3</sub>	D	
15	LLRHZ 15 S1	33	26,4	19,2	24,6	6,3	4,6	3,5	1,0	4
20	LLRHZ 20 S1	42	40,0	24,8	32,4	6,8	5,1	4,0	1,0	6
25	LLRHZ 25 S1	47	41,6	29,5	38,3	11,0	7,0	4,0	1,0	8
30	LLRHZ 30 S1	59	52,8	34,7	48,4	14,1	7,0	4,0	1,0	12
35	LLRHZ 35 S1	69	60,9	40,1	58,0	17,0	7,0	4,0	1,0	16
35*	LLRHZ 35 S1 CS	69	60,9	40,1	58,0	17,0	7,0	4,0	1,0	16
45	LLRHZ 45 S1	85	76,7	50,0	69,8	20,5	7,0	5,0	2,0	50
45*	LLRHZ 45 S1 CS	85	76,7	50,0	69,8	20,5	7,0	5,0	2,0	50

\* Scraper plates in combination with cover strip



### 3.3.2 Two-piece front seal

Additional front seals are contact seals that can be attached to the carriage end faces. They are singlelip seals consisting of special heavy-duty material and offer additional protection against liquids and smaller contaminants.

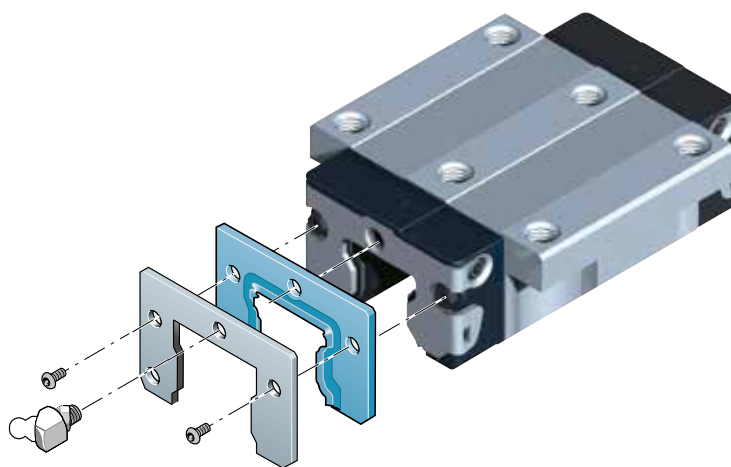

#### Dimensional drawing

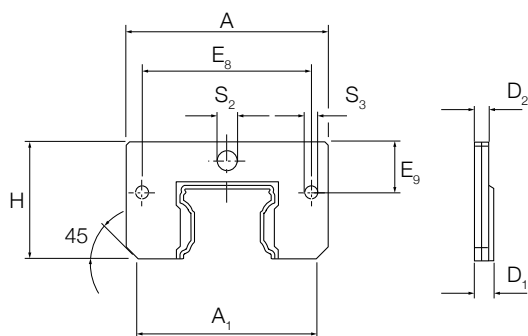

#### Technical data

Size	Part numbers	Dimensions (mm)										Weight (g)
		A	A <sub>1</sub>	H <sub>2</sub>	W <sub>3</sub>	E <sub>9</sub>	S <sub>2</sub>	S <sub>3</sub>	D <sub>1</sub>	D <sub>2</sub>		
15	LLRHZ	15 S2	32	27	19,0	24,55	6,3	3,5	3,5	3,0	2,2	6
20	LLRHZ	20 S2	42	39	24,3	32,40	6,8	5,1	4,0	3,3	2,5	8
25	LLRHZ	25 S2	47	42	29,0	38,30	11,0	7,0	4,0	3,3	2,5	10
30	LLRHZ	30 S2	59	53	34,5	48,40	14,1	7,0	4,0	4,5	3,3	18
35	LLRHZ	35 S2	69	61	39,5	58,00	17,0	7,0	4,0	4,5	3,3	25
45	LLRHZ	45 S2	85	77	49,5	69,80	20,5	7,0	5,0	5,5	4,0	55

### 3.3.3 Seal kit

The seal kit consists of the following components:

1. Scraper plate
2. Support plate
3. Two-piece front seal

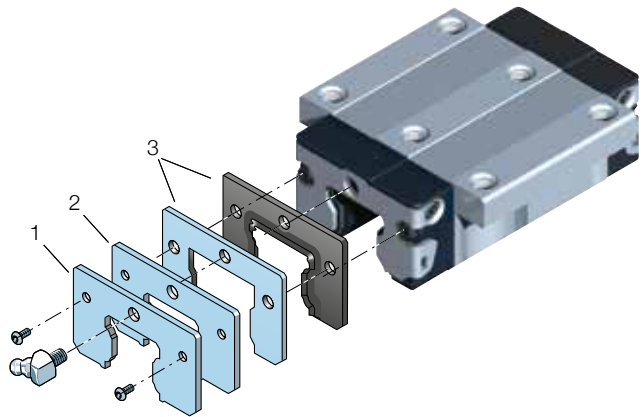

#### Technical data

Size	Seal kit Designation
15	LLRHZ 15 S3
20	LLRHZ 20 S3
25	LLRHZ 25 S3
30	LLRHZ 30 S3
35	LLRHZ 35 S3
35 CS*	LLRHZ 35 S3 CS
45	LLRHZ 45 S3
45 CS*	LLRHZ 45 S3 CS

\* Seal kit in combination with cover strip

## 3.3.4 Bellows

### Material:



Bellows are made out of polyester fabric with polyurethane coating

Adapter plates are made out of aluminium.

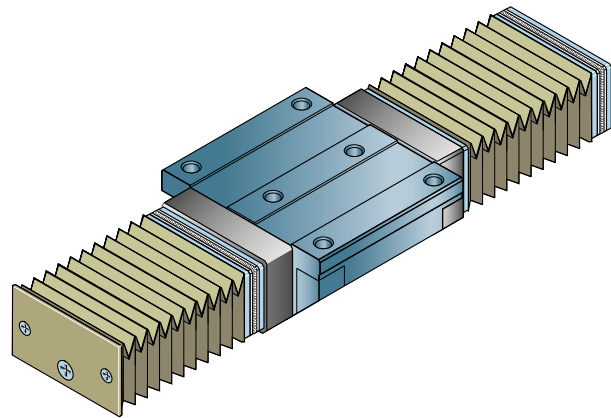
The lubrication nipple on the carriage can be used.



### Technical data

Size	Type 2 	Type 4 	Type 9 
	with fastening plate for the carriage and end plate for the rail	with two fastening plates for the carriages	loose bellows (spare part)
15	LLRHB 15 B2 xx	LLRHB 15 B4 xx	LLRHB 15 xx
20	LLRHB 20 B2 xx	LLRHB 20 B4 xx	LLRHB 20 xx
25	LLRHB 25 B2 xx	LLRHB 25 B4 xx	LLRHB 25 xx
30	LLRHB 30 B2 xx	LLRHB 30 B4 xx	LLRHB 30 xx
35	LLRHB 35 B2 xx	LLRHB 35 B4 xx	LLRHB 35 xx
45	LLRHB 45 B2 xx	LLRHB 45 B4 xx	LLRHB 45 xx

xx = Number of folds

### 3.3.5 Lubrication adapter

For high carriages: LLRHC\_R LLRHC\_LR

- Material: plastic
- Contents: 1 piece

**Mounting:** O-rings are supplied.



#### Dimensional drawing

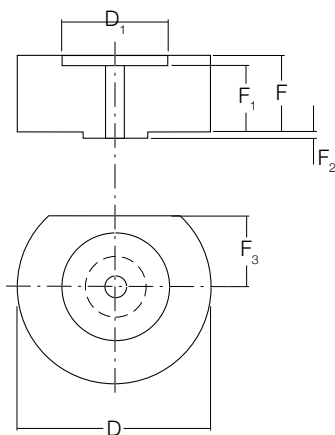

#### Technical data

Size	Part numbers	Dimensions (mm)						
		D	D <sub>1</sub>	D <sub>2</sub>	F	F <sub>1</sub>	F <sub>2</sub>	F <sub>3</sub>
15	LLRHZ 15 0	12	6,2	3,4	3,7	3,1	0,5	3,20
25	LLRHZ 25 0	15	7,2	4,4	3,8	3,2	0,5	5,85
30	LLRHZ 30 0	16	7,2	4,4	2,8	2,2	0,5	6,10
35	LLRHZ 35 0	18	7,2	4,4	6,8	6,2	0,5	6,80
45	LLRHZ 45 0	20	7,2	4,4	9,8	9,2	0,5	8,30

## 3.3.6 Cover strip

### Advantages of the cover strip

The cover strip can be simply clipped on and pulled off.

- This considerably simplifies and quickens mounting:
  - It is not necessary to close every single drill hole
  - It is not necessary to wait for the adhesive to set on adhesive strips.
- Multiple mounting and removal is possible (up to 4 times)

### Cover strip with fixed seat (standard)

- The cover strip is clipped on before the carriages are mounted and stays firmly in place.

With an optionally available expanding mandrel for 0,15 mm cover strips or a special expanding tool for 0,3 mm cover strips a slide can also be retroactively created in order to remove a cover strip.

In particular, however, the slide length X can be optimally adapted to the specific application.

Please observe the precise mounting instructions!

### Cover strip for initial mounting/ stock/ replacement

For each guide rail length a matching cover strip with fixed seat can be supplied.

Ordering a standard cover strip with fixed seat

#### Example:

Rail Size 35,

Rail length L = 2 696 mm

LLRHZ 15 – 2 969 CS

(For order designation see product table)

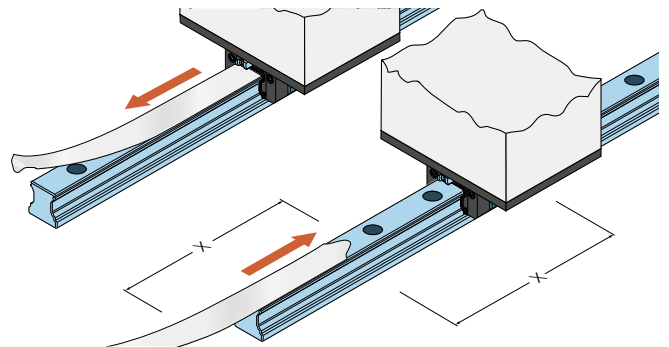
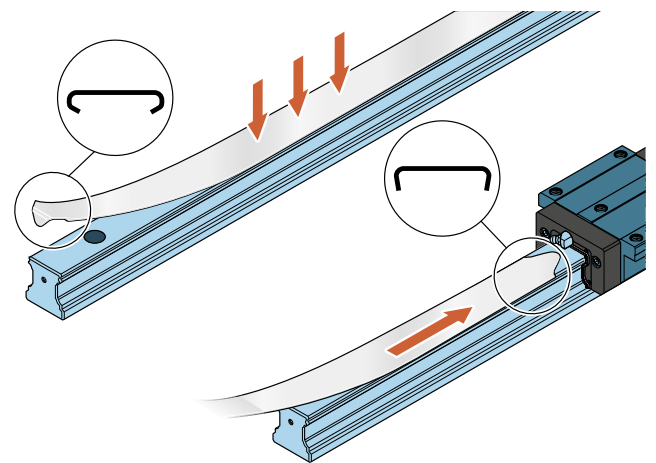
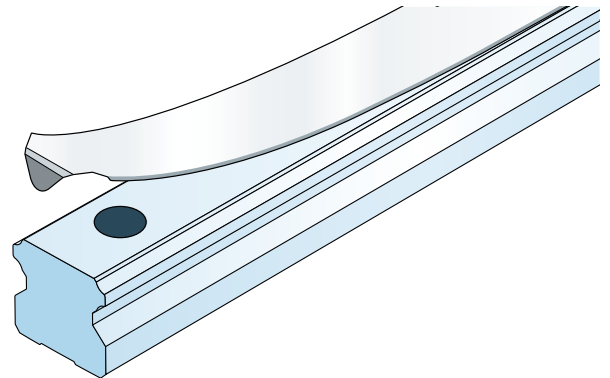

Size	Standard cover strips Order designation, length (mm)
------	---

15	LLRHZ 15 - xxx CS
20	LLRHZ 20 - xxx CS
25	LLRHZ 25 - xxx CS
30	LLRHZ 30 - xxx CS
35	LLRHZ 35 - xxx CS
45	LLRHZ 45 - xxx CS

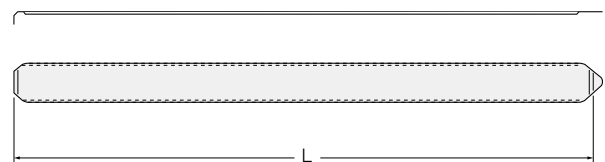

### 3.3.7 Expanding mandrel to create a slide on the cover strip

Size	Expanding mandrel Order designation
15	LLRHZ 15 W
20	LLRHZ 20 W
25	LLRHZ 25 W
30	LLRHZ 30 W
35	LLRHZ 35 W
45	LLRHZ 45 W

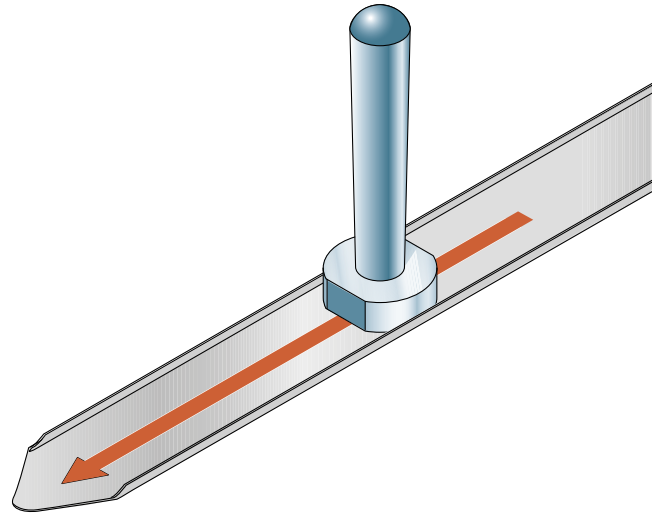

### 3.3.8 Cover strip retaining clamps

For guide rails without end-face threaded holes.

Ewellix recommends the use of cover strip retaining clamps.

These can:

- prevent unintentional removal of the strip and incursion of dirt
- fix the cover strip in place

**Materials:**

Retaining clamps made of aluminium, black anodised. Clamping screw and nut made of corrosion-resistant steel.

Order designations for cover strip retaining clamps

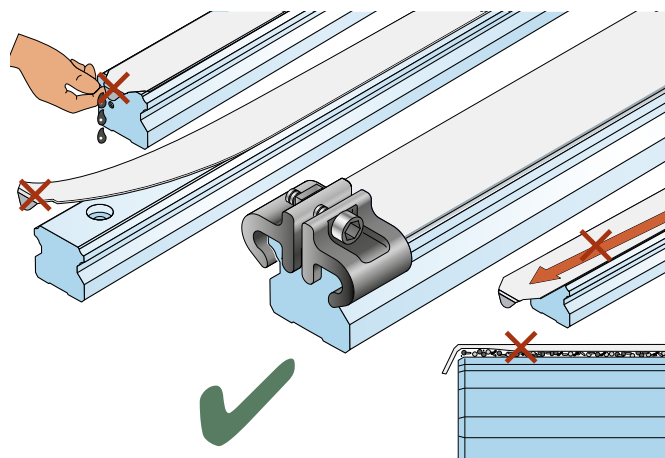

**Dimensional drawing**

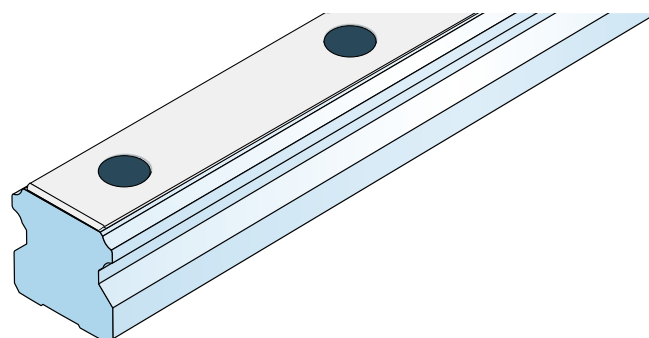
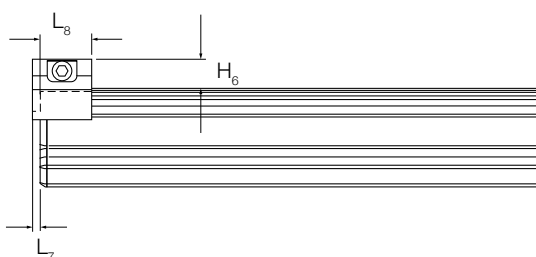

Plastic caps are supplied as standard if a cover strip has not been ordered.

**Technical data**

Size	Retaining clamps (2 pieces per unit) Order designation	Dimensions (mm)		
		H <sub>6</sub>	L <sub>7</sub>	L <sub>8</sub>
15	LLR 15 CSG	7,3	2,0	12
20	LLR 20 CSG	7,1	2,0	12
25	LLR 25 CSG	8,2	2,0	13
30	LLR 30 CSG	8,7	2,0	13
35	LLR 35 CSG	11,7	2,2	16
45	LLR 45 CSG	12,5	2,2	18



4

**Mounting  
instruction and  
maintenance**





# 4.1 Design rules

## 4.1.1 General instructions

The following mounting instructions apply to all profile rail guides.

Please note, however, that differing specifications exist concerning the parallelism of the rails as well as the screwing and pinning of the carriages. These are therefore assigned to the individual versions.

Ball profile rail guides are high-quality products. Greatest possible care should be taken during transport and subsequent assembly. All steel parts have been oil-protected. The protection materials do not need to be removed if the recommended lubricants are used.

Detailed mounting instructions are available through your normal Ewellix contact.

## 4.1.2 Assembly examples

### Rails

Each rail has ground reference edges on both sides.

Options for lateral fixing:

1. Stop edges
2. Clamp strips
3. Wedge strips

**NOTE:** The rail must have a chamfer to prevent the seal from being damaged. This is not the case for joint rail tracks

Rails without lateral fixing must be aligned straight and parallel during assembly, preferably using an auxiliary strip. (Guide values for the permissible lateral force without additional lateral fixing can be obtained from the information for the individual versions).

### Carriage

Each carriage has a ground reference edge on one side (<dimension H3 in the dimensional drawings). Additional fixing options:

1. Reference edges
2. Retaining strips
3. Clamp strips
4. Pinning

**NOTE:** After being successfully mounted the carriage should move easily when pushed.

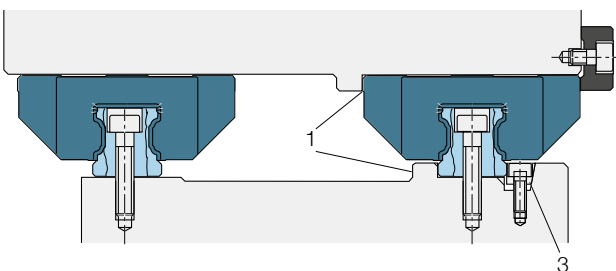
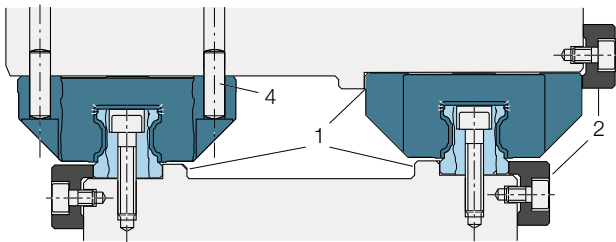

### 4.1.3 Stop edges, corner radii, screw sizes and tightening torques

#### Carriages made of steel, type A, LA

- Standard width

#### Rails

- Can be screwed from above

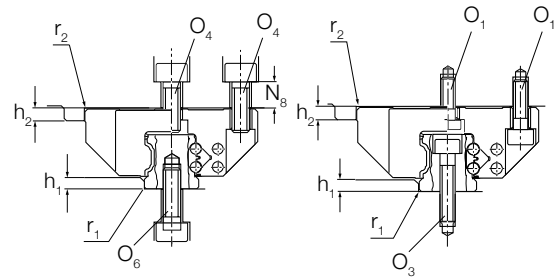

#### Carriages made of steel, type U, LU, R, LR

#### Rails

- Can be screwed from above

The combinations shown are examples. In principle all carriages can be combined with all rails.

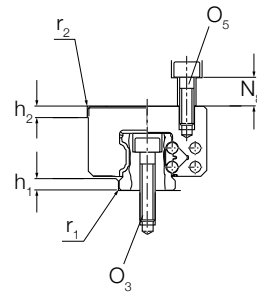

#### Technical data

Size	Dimensions					Screw						
	h <sub>1</sub> min	h <sub>1</sub> max	r <sub>1</sub> max	h <sub>2</sub>	r <sub>2</sub> max	O <sub>1</sub> DIN 912 4 Pieces	O <sub>2</sub> <sup>2)</sup> DIN 6912 2 Pieces	O <sub>4</sub> <sup>1)2)</sup> DIN 912 6 Pieces	O <sub>5</sub> DIN 912 4 Pieces	O <sub>3</sub> DIN 912	O <sub>6</sub> DIN 912	N <sub>8</sub> mm
15	2,5	3,5	0,4	4	0,6	M4x12	M4x10	M5x12	M4x12	M4x20	M5x12	6
20	2,5	4,0	0,6	5	0,6	M5x16	M5x12	M6x16	M5x16	M5x25	M6x16	9
25	3,0	5,0	0,8	5	0,8	M6x20	M6x16	M8x20	M6x18	M6x30	M6x20	10
30	3,0	5,0	0,8	6	0,8	M8x25	M8x16	M10x20	M8x20	M8x30	M8x20	10
35	3,5	6,0	0,8	6	0,8	M8x25	M8x20	M10x25	M8x25	M8x35	M8x25	13
45	4,5	8,0	0,8	8	0,8	M10x30	M10x25	M12x30	M10x30	M12x45	M12x30	14

#### Dimensions and guide values for permissible lateral force without additional lateral fixing

	Screw strength class	Carriages			Rails		
Carriages A, U, R	8.8	0,11 C	0,15 C <sup>3)</sup>	0,23 C	0,11 C	0,06 C	0,06 C
	12.9	0,18 C	0,22 C <sup>3)</sup>	0,35 C	0,18 C	0,10 C	0,10 C
Carriages LA, LU, LR	8.8	0,08 C	0,13 C <sup>3)</sup>	0,18 C	0,08 C	0,04 C	0,04 C
	12.9	0,14 C	0,18 C <sup>3)</sup>	0,26 C	0,14 C	0,07 C	0,07 C

<sup>1)</sup> If the carriage is fastened from above with only four O<sub>4</sub> screws:  
 - permissible lateral force 1/3 lower  
 - lower stiffness

<sup>2)</sup> If the carriage is fastened with 6 screws:  
 Tighten the middle screws with a tightening torque for strength class 8.8

<sup>3)</sup> If fastened with two O<sub>2</sub> screws and four O<sub>1</sub> screws

#### Tightening torques of the fixing screws in Nm

	M4	M5	M6	M8	M10	M12	M14	M16
	8.8	2,7	5,5	9,5	23	46	80	125
	12.9	4,6	9,5	16	39	77	135	215

## Carriages SA

- Standard width, short

### Rails

- Can be screwed from above

## Carriages SU

- Slim line short

### Rails

- Can be screwed from above

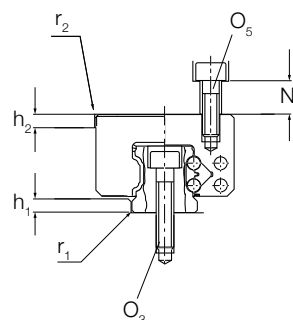
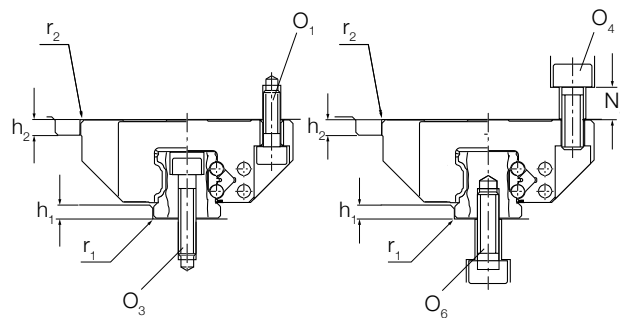

**NOTE:** The combinations shown are examples. In principle all carriages can be combined with all rails.

The screw connection for the carriages using 2 screws is completely adequate to withstand the maximum load. (See maximum load ability and moment loadability for the individual versions.)

## Technical data

Size	Dimensions					Screw					
	$h_1$ min mm	max	$r_1$ max	$h_2$	$r_2$ max	$O_1$ DIN 912 2 Pieces	$O_4$ DIN 912 2 Pieces	$O_5$ DIN 912 2 Pieces	$O_3$ DIN 912 Rail	$O_6$ DIN 912 Rail	$N_8$ mm
15	2,5	3,5	0,4	4	0,6	M4x12	M5x12	M4x12	M4x20	M5x12	6
20	2,5	4,0	0,6	5	0,6	M5x16	M6x16	M5x16	M5x25	M6x16	9
25	3,0	5,0	0,8	5	0,8	M6x20	M8x20	M6x18	M6x30	M6x20	10
30	3,0	5,0	0,8	6	0,8	M8x25	M10x20	M8x20	M8x30	M8x20	10
35	3,5	6,0	0,8	6	0,8	M8x25	M10x25	M8x25	M8x35	M8x25	13

## Dimensions and guide values for permissible lateral force without additional lateral fixing

Screw strength class	Carriages		Rails			
	0,08 C	0,12 C	0,08 C	0,09 C	0,09 C	0,04 C
8.8	0,08 C	0,12 C	0,08 C	0,09 C	0,09 C	0,04 C
12.9	0,13 C	0,21 C	0,13 C	0,15 C	0,15 C	0,07 C

## Tightening torques of the fixing screws in Nm

Screw	M4	M5	M6	M8	M10	M12	M14	M16
	8.8	2,7	5,5	9,5	23	46	80	125
12.9	4,6	9,5	16	39	77	135	215	340

## 4.1.4 Pinning

### Carriage standard width A, LA, slim line U, LU, slim line high R, LR

If the guide values for the permissible lateral force are exceeded (see table) the carriage must be additionally fixed by means of pinning or stop edges.

The recommended dimensions for the pin holes can be obtained from the drawings and table.

#### Usable pins:

- tapered pin (hardened) or
- straight pin DIN ISO 8734

#### Instructions

For production-related reasons there may be pilot drill holes in the middle of the carriage at the recommended positions for pin holes ( $\varnothing < S_{10}$ ). They are suitable for drilling.

If necessary, the pinning must be carried out in a different position (e.g. middle lube port), but must not exceed the dimension  $L_3$  in longitudinal direction ( $L_3$  can be obtained from the dimension tables for the individual versions).

Keep to dimensions  $W_2$  and  $W_4$ !

Do not complete the pin holes until after mounting (see also general mounting instructions - available through your normal contact).

Standard width A, LA

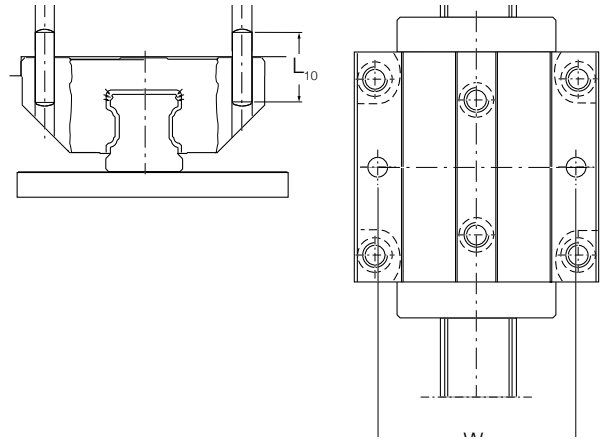

Slim line U, LU, Slim line high R, LR

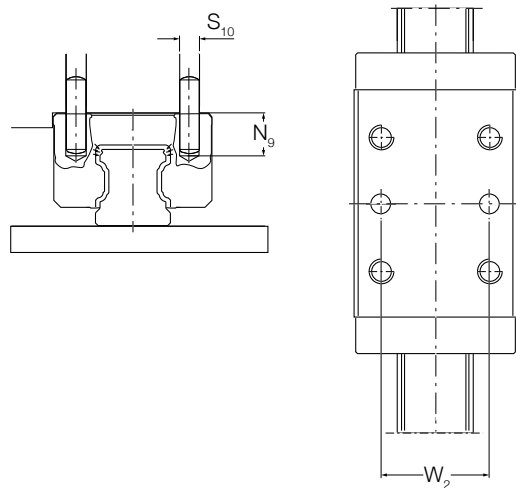

#### Technical data

Size	Dimensions Tapered pin (hardened) or straight pin (DIN 6325) $S_{10}$ mm	Dimensions (mm)			
		$L_{10}$	$W_2$	$W_4$	$N_9$ (max)
15	4	18	26	38	6,0
20	5	24	32	53	7,5
25	6	32	35	55	9,0
30	8	36	40	70	12,0
35	8	40	50	80	13,0
45	10	50	60	98	18,0

### Carriage flange short, SA, slim line, SU

If the guide values for the permissible lateral force are exceeded (see table) the carriage must be additionally fixed by means of pinning or stop edges.

The recommended dimensions for the pin holes can be obtained from the drawings and table.

#### Usable pins:

- tapered pin (hardened) or
- straight pin DIN ISO 8734

#### Instructions

For production-related reasons there may be pilot drill holes in the middle of the carriage at the recommended positions for pin holes ( $\varnothing < S_{10}$ ). They are suitable for drilling.

Flange short, SA

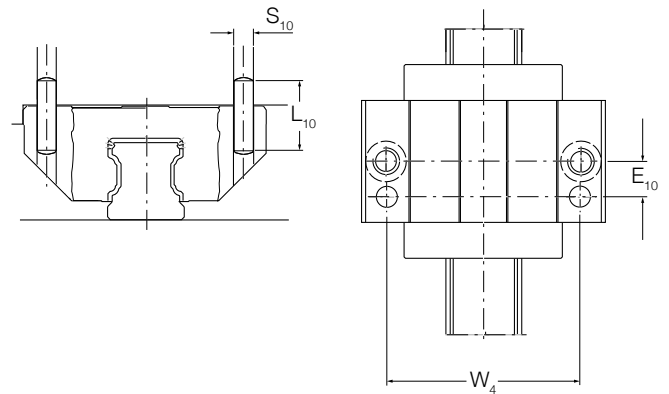

Slim line, SU

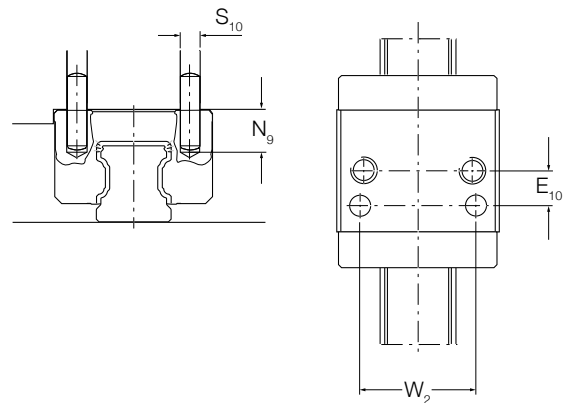

### Technical data

Size	Dimensions	Dimensions (mm)				
	$S_{10}$ mm	$L_{10}$	$W_4$	$W_2$	$E_{10}$	$N_9$ (max)
15	4	18	38	26	9	3,0
20	5	24	53	32	10	3,5
25	6	32	55	35	11	7,0
30	8	36	70	40	14	10,0
35	8	40	80	50	15	12,0

Tapered pin (hardened), straight pin (DIN 6325)



## 4.1.5 Loading of the screw connections between rail and substructure

The screw connections specified in the DIN 645-1 standard can become excessively loaded owing to the high performance capacity of the profile rail guides.

The screw connection between the guide rail and the substructure is critical. If the lift-off loads (F) or moments (Mt) are higher than the respective load values in the table, the screw connection must be recalculated separately.

The figures apply to the following conditions:

- Grade 12.9 fixings screws
- Screws tightened using a torque wrench
- Slightly oiled screws (for grade 8.8 screws approximately a reduction factor of 0,6 can be applied)

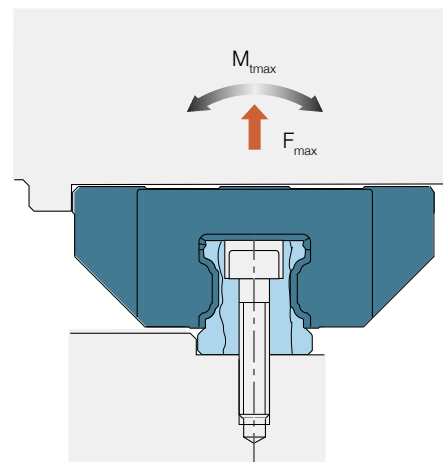

*Lift-off loads and moment  
Rail screwed from above*

### Technical data

Carriage	LLRH--SA, LLRH--SU		LLRH--A, LLRH--U, LLRH--R		LLRH--LA, LLRH--LU, LLRH--LR	
	F <sub>max</sub> N	M <sub>t,max.</sub> Nm	F <sub>max</sub> N	M <sub>t,max.</sub> Nm	F <sub>max</sub> N	M <sub>t,max.</sub> Nm
15	6 040	41	7 050	47	8 060	54
20	10 000	90	11 700	106	13 400	121
25	14 600	154	17 100	180	19 500	205
30	-	360	32 400	420	37 100	480
35	27 500	440	32 100	510	36 700	580
45	-	-	78 100	1 680	89 300	1 920

## 4.1.6 Height deviation

The values for height deviation apply to all carriages.

Approximately 20 % higher values are permissible for the SA (standard width short) and SU (slim line short) carriages.

Given adherence to the permissible height deviation  $S_1$  and  $S_2$ , the influence on the service life is generally negligible.

### Permissible height deviation in lateral direction

In the permissible height deviation  $S_1$ , the tolerance for dimension H according to the table is already taken into account in "Technical Data".

$$S_1 = a \times Y$$

$S_1$  = Permissible height deviation (mm)

a = Distance between the rails (mm)

Y = Calculation factor

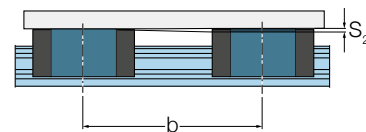
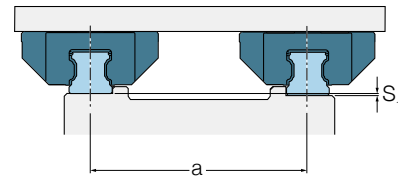

### Permissible height deviation in longitudinal direction

#### For carriages

In the permissible height deviation  $S_2$  the tolerance "maximum difference of dimension H on a rail" according to the table is already taken into account in "Technical Data".

Approximately 40 % higher values are permissible for SA and SU carriages.

On A-type carriages (standard width long), LU and LR approx. 30 % lower values are permissible.

### Permissible height deviation $S_2$ on carriages

$$S_2 = b \times 4,3 \times 10^{-5}$$

$S_2$  = Permissible height deviation (mm)

b = Distance between the carriages (mm)

### Calculation factor Y for carriages

Calculation factor	Preload class			
	T0 up to approx. 10 $\mu$ m clearance	T1 Preload 0,02 C	T2 Preload 0,08 C	T3 Preload 0,13 C
Y	$4,3 \times 10^{-4}$	$2,8 \times 10^{-4}$	$1,7 \times 10^{-4}$	$1,2 \times 10^{-4}$

## 4.1.7 Parallelism of mounted rails measured on the rails and the carriages

The values for the deviation in parallelism  $P_1$  apply to all carriages.

Approximately 20 % higher values are permissible for the SA and SU carriages.

Deviation in parallelism  $P_1$  for carriages

Through the deviation in parallelism  $P_1$  the preload is increased somewhat on one side.

If the table values are adhered to, the influence on the service life is generally negligible.

The values shown in the following table apply to applications in which highest precision is required.

For all other uses and for general mechanical engineering doubled values can be applied.

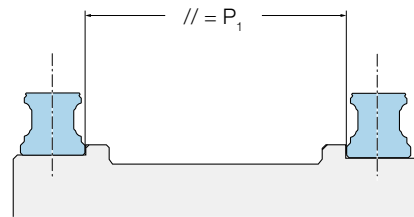

### Technical data

Size	Deviation in parallelism P1 (mm) for high precision demands			
	T0 up to approx. 10 µm clearance	T1 Preload 0,02 C	T2 Preload 0,08 C	T3 Preload 0,13 C
15	0,015	0,009	0,005	0,004
20	0,018	0,011	0,006	0,004
25	0,019	0,012	0,007	0,005
30	0,021	0,014	0,009	0,006
35	0,023	0,015	0,01	0,007
45	0,028	0,019	0,012	0,009



## 4.1.8 Mounting of lubrication adapter

A lubrication adapter is necessary on high carriages if lubrication is to take place from the table part.

**⚠ In the recess for the O-ring seal a further small recess (1) has been performed. Do not drill this open. Risk of dirt incursion!**

- Heat up metal tip (2) with a diameter of 0,8 mm.
- Carefully open the recess (1) with the metal tip and push through.  
Observe maximum permissible depth  $T_{max}$  stated in the table!
- Insert O-ring seal (3) in the recess.
- Insert lubrication adapter at an angle in the recess and press the flattened side (4) onto the steel part (5). Use grease for fixing.
- Insert O-ring seal (6) in the lubrication adapter.

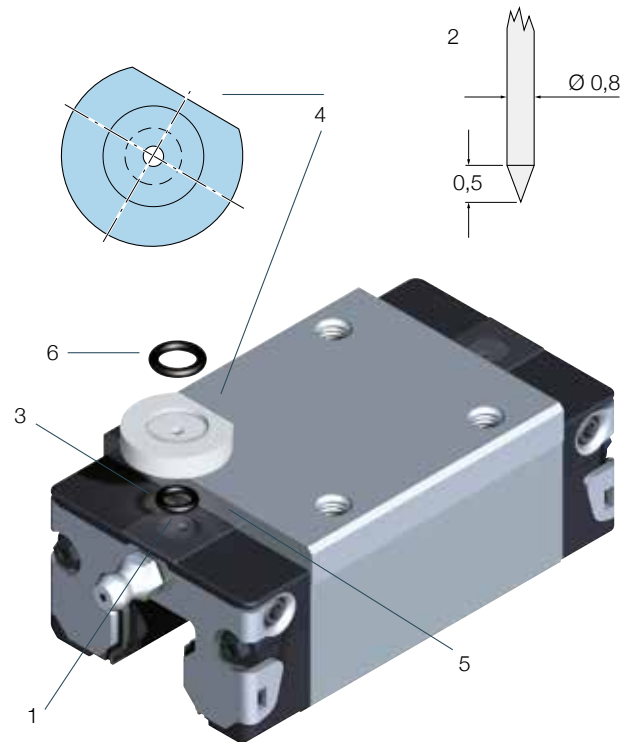

### Size

Top lubrication opening: maximum permissible depth for penetration  $T_{max}$  (mm)

### Dimensional drawing

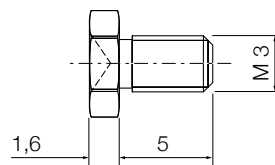
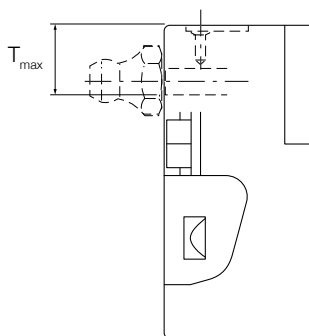

DIN 3405, funnel-type nipple for carriage size 15 and 20

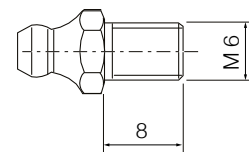

DIN 71412, cone-type nipple for carriage size 25, 30, 35 and 45

### Technical data

Size	Top lubrication opening: maximum permissible depth for penetration $T_{max}$ (mm)
15	3,6
20	3,9
25	3,3
30	6,6
35	7,5
45	8,8

## 4.1.9 Mounting bellow

The bellows are pre-mounted.  
The fixing screws are supplied.

On type 2 in each case one thread M4-10 deep, 2 x 45° countersunk, must be inserted in the end face of the rail.

Size 25 - 45:

The lubrication nipple on the carriage can be used.

Size 15 and 20:

A drive-type lubrication nipple is supplied.

### Calculation of the bellows

$$L_{min} = L_{max} - \text{Stroke}$$

$$L_{max} = (\text{Stroke} + 30) \cdot U$$

$$\text{Number of folds} = \frac{L_{max}}{W} + 2$$

$L_A$  = Carriage length  $L_1$  plus 2x12 mm for the fastening plates.

$L_{max}$  = Bellows stretched

$L_{min}$  = Bellows pushed together

Stroke = Stroke (mm)

U = Calculation factor

W = Maximum extension of folds

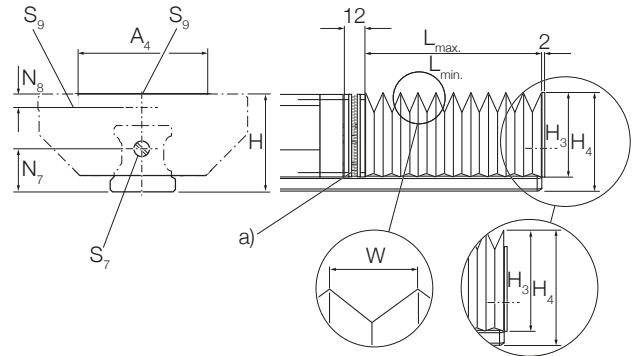

### Calculation of the rail length

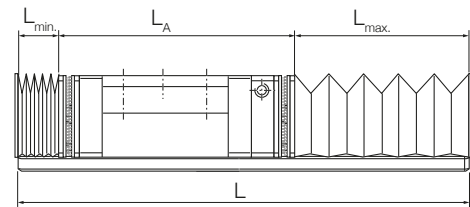

$$L = L_{min} + L_{max} + L_A$$

L = Rail length (mm)

### Technical data

Size	Dimensions (mm)											Factor	
	A <sub>4</sub>	B <sub>3</sub>	H	H <sub>3</sub>	H <sub>4</sub>	N <sub>7</sub>	N <sub>8</sub>	S <sub>7</sub>	S <sub>8</sub>	S <sub>9</sub>	W	U	
15	45	11	24	26,5	31,5	11	3,4	M4	∅3	M3	19,9	1,18	
20	42	12	30	24,0	29,2	13	3,5	M4	∅3	M3	10,3	1,33	
25	45	12	36	28,5	35,0	15	6,0	M4	M6	M3	12,9	1,32	
30	55	12	42	34,0	41,0	18	8,0	M4	M6	M6	15,4	1,25	
35	64	12	48	39,0	47,0	22	8,0	M4	M6	M6	19,9	1,18	
45	83	12	60	49,0	59,0	30	8,0	M4	M6	M6	26,9	1,13	

# 4.2 Maintenance and repairs

## As a function of the stroke length

### Stroke > 2 × length of the carriage

1 lube port needs to be provided per carriage (↳ fig. 1).

- Oil lubrication in accordance with ISO VG 220.

For lubrication quantities please refer to the next page.

### Stroke < 2 × length of the carriage

• 2 lube ports need to be provided per carriage (↳ fig. 2).

- Apply the prescribed lubricant quantity per lube port.
- Oil lubrication in accordance with ISO VG 220.

For lubrication quantities please refer to the next page.

## Installation in inclined or side position (wall mounting)

### Stroke > 2 × length of the carriage

• 1 lube port needs to be provided per carriage (↳ fig. 3).

- Apply the lubricant quantity stated in the table with an impulse.
- If the lubricant quantity cannot be applied with an impulse, please consult Ewellix.

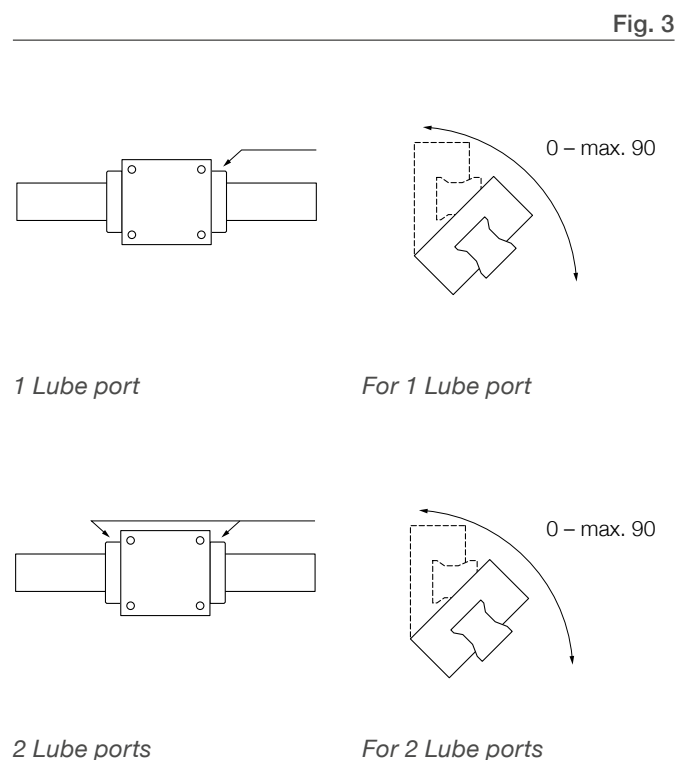
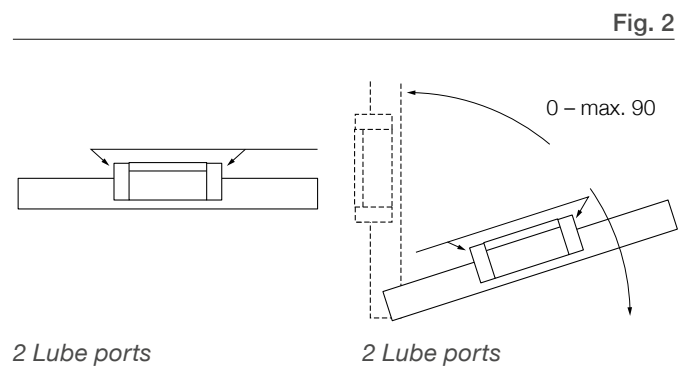
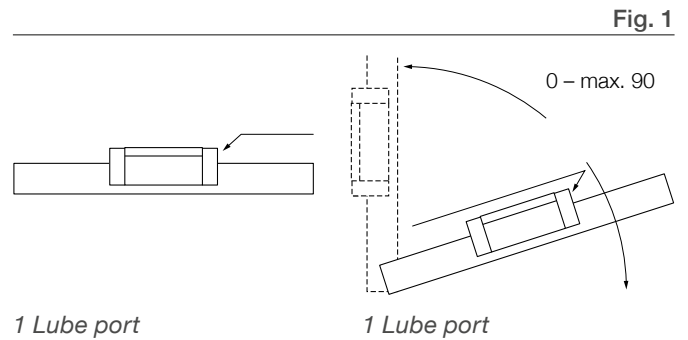

## Maintenance

Dirt can drop and settle on exposed rails in particular. To maintain the function of seals and cover strips, such dirt must be regularly removed.

For this purpose a “cleaning stroke” should be carried out over the entire length of travel at least twice a day, and at the latest after eight hours.

Carry out a cleaning stroke each time before switching off the machine.

## Lubrication

Grease lubrication

Initial lubrication of the carriage (basic lubrication)

No initial lubrication is required if the carriage has been greased at the factory.

The initial lubrication takes place with three times the part quantity stated in **Table 1**:

1. Grease the carriage with the first part quantity stated in **table 1**.
2. Move the carriage backwards and forwards with three double strokes along at least three times the carriage length.
3. Repeat step 1 and 2 twice.
4. Check whether a lubricating film is visible on the rail.

Ball rail guides are supplied in protected form. With basic greasing at the factory, both grease and oil lubrication is possible.

For lubrication we recommend lubricating grease to DIN 51825: – KP2K-20, consistency class NLGI 2 to DIN 51818. This can be obtained from Ewellix, see recommendation for lubricating greases.

Never start to use carriages without basic lubrication.

Observe the manufacturer’s instructions, in particular instructions concerning incompatibilities.

**⚠ Greases with a proportion of solid lubricant (such as graphite) should not be used!**

## Re-lubricating the carriage

When the re-lubrication interval according to **Table 2** has been reached, the carriage must be lubricated with the lubricant quantity as stated in **Table 1**. Where such environmental influences as dirt, the use of coolants, vibration, shock loads etc. are encountered, we recommend that the re-lubrication intervals be shortened accordingly.

Longer re-lubrication intervals apply in the case of smaller loads.

### Short stroke

#### Stroke < 2 × carriage length

- 2 lube ports need to be provided per carriage and lubricated in each case!

#### Stroke < 0,5 × carriage length

- 2 lube ports need to be provided per carriage and lubricated in each case!
- For each lubrication cycle move the carriage 2 × the carriage length. If this is not possible, please consult Ewellix.

Lubricant quantities as stated in **Table 1** (re-lubrication). Apply the stated quantity for each lube port.

\* NLGI 00 greases reduce the relubrication intervals to 75 % of the values stated in **Table 2**.

Table 1

Size	Grease lubrication Initial lubrication by customer Part quantity (cm <sup>3</sup> )	Re-lubrication Part quantity (cm <sup>3</sup> )
15	0,4 (x 3)	0,4 (x 2)
20	0,7 (x 3)	0,7 (x 2)
25	1,4 (x 3)	1,4 (x 2)
30	2,2 (x 3)	2,2 (x 2)
35	2,2 (x 3)	2,2 (x 2)
45	4,7 (x 3)	4,7 (x 2)

Table 2

Size	Grease lubrication Relubrication intervals under normal operating conditions, v ≤ 1 m/s	
	Travel (km) under load ≤ 0,15 C	≤ 0,3 C
15	5 000	1 200
20	5 000	1 200
25	10 000	2 400
30	10 000	2 400
35	10 000	2 400

## Oil lubrication

Oil quantities for initial lubrication and re-lubrication

**⚠ Apply the entire quantity of oil with a single lubrication impulse!**

Carriages initially greased at the factory can also be re-lubricated with oil.

In the case of carriages which have not been initially greased at the factory, carry out the initial lubrication in accordance with **Table 3**.

If environmental influences such as dirt, use of coolants, vibration, shock loads etc. are encountered, we recommend that the re-lubrication intervals be shortened accordingly.

Refer to **Table 4**.

### Central oil lubrication

#### Oil quantities and lubrication impulses for central oil lubrication

**NOTE:** Recommended waiting time between the impulses: 10 seconds.

#### For example size 45:

4 impulses with in each case 0,6 cm<sup>3</sup> in 30 seconds.

Refer to **Table 5**.

Table 3

Size	Oil lubrication Initial lubrication by customer Part quantity (cm <sup>3</sup> )	Re-lubrication Part quantity (cm <sup>3</sup> )
15	0,4 (x 2)	0,4
20	0,7 (x 2)	0,7
25	1,0 (x 2)	1,0
30	1,1 (x 2)	1,1
35	1,2 (x 2)	1,2
45	2,2 (x 2)	2,2

Table 4

Size	Oil lubrication Re-lubrication intervals under normal operating conditions, v ≤ 1 m/s	
	Travel (km) under load ≤ 0,15 C	≤ 0,3 C
15	2 500	600
20	2 500	600
25	5 000	1 200
30	5 000	1 200
35	5 000	1 200

Table 4

Size	Central oil lubrication	
	Oil quantities Impulse (cm <sup>3</sup> )	Impulses per lubrication cycle Number of impulses
15	0,6	1
20	0,6	1
25	0,6	2
30	0,6	2
35	0,6	2
45	0,6	4





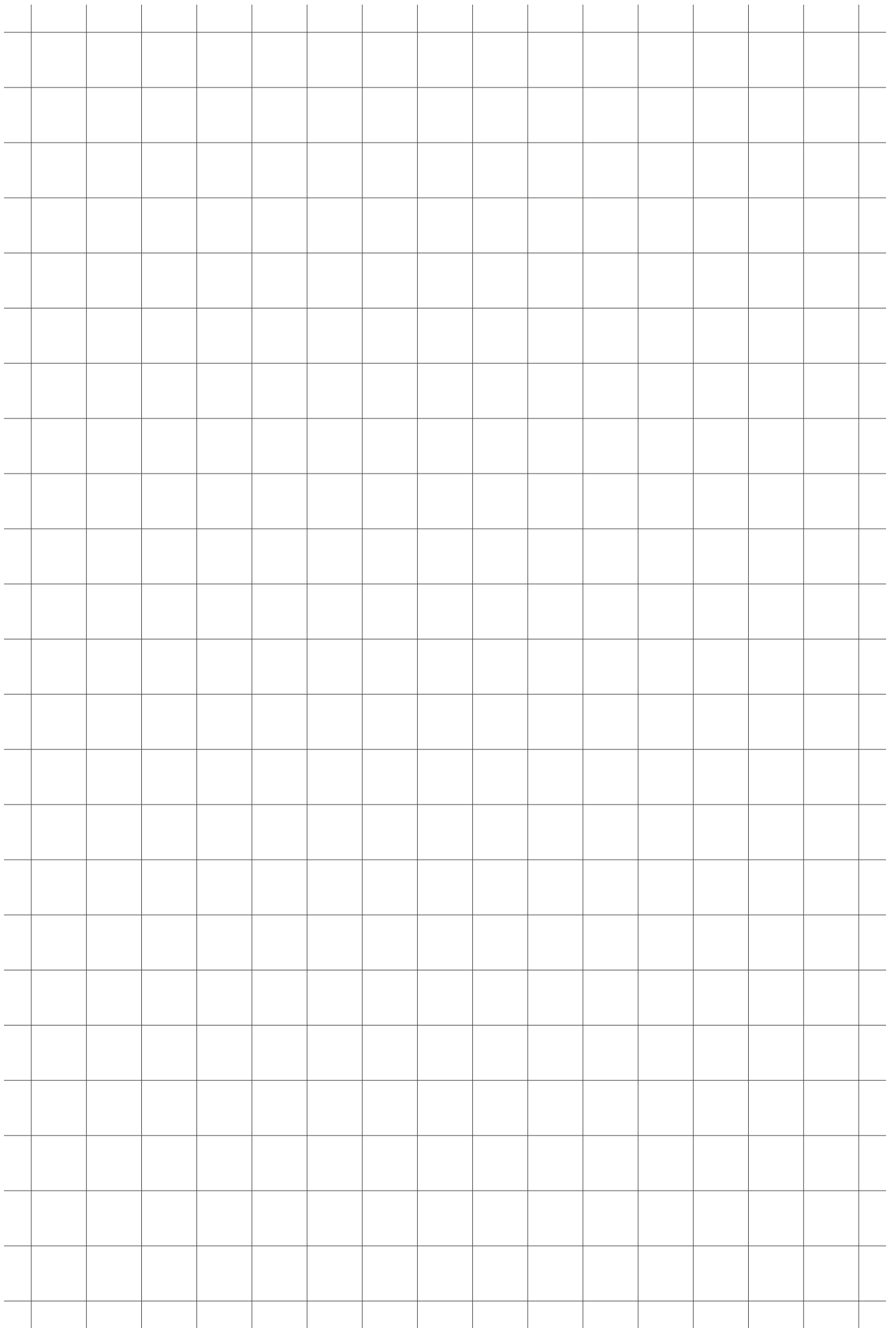







**ewellix.com**

© Ewellix

All contents of this publication are the property of Ewellix, and may not be reproduced or given to third parties (even extracts) without permission. Although great care has been taken in the production of this catalog, Ewellix does not take any responsibility for damage or other loss resulting from omissions or typographical errors. The photo may differ slightly in appearance from the actual product. Due to continuous improvements being made in our products, the product's appearance and specifications are subject to change without notice.

**PUB NUM IL-06016/2-EN-February 2023**

Certain image(s) used under license from Shutterstock.com.  
Schaeffler and the Schaeffler logo are trademarks of the Schaeffler Group.