

EWELLIX

A Schaeffler Company

Electric cylinder SRSA and SVSA

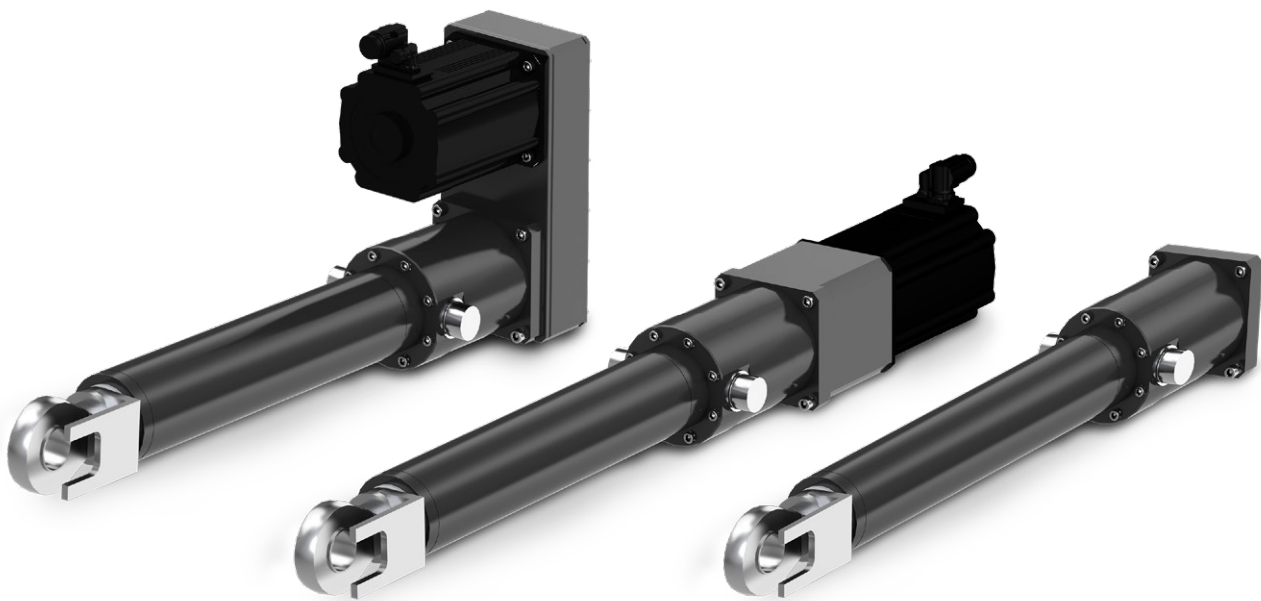

Electric cylinders SRSA and SVSA

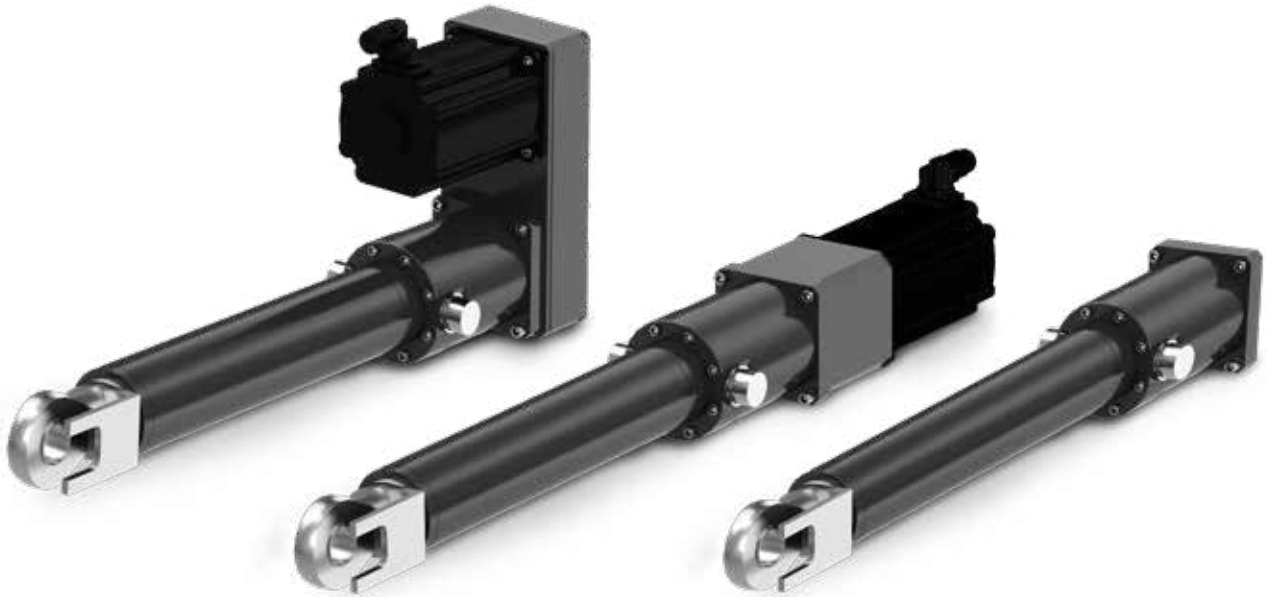

Features

- High performance roller screw
- Steel push tube and protection tube
- Modular concept
- Anti-rotation with profile rail guide
- Possibility to re-lubricate the roller screw nut with direct access
- Optional low lead roller screw or high-lead ball screw available.
- Brushless servo motors and customized motor adapters

Benefits

- High load with long life capacity as well as high acceleration and speed capabilities
- High stiffness and robustness
- Multiple combinations to fit a wide range of applications
- Extreme push tube torque resistance
- Low maintenance requirements
- Optimal solution for a wide range of applications where high load, high positioning accuracy or high speed is needed.

Product description

Electric cylinders SRSA are a straight forward combination of Ewellix's high quality planetary roller screws, SKF's angular contact ball bearings that will hold load and servomotors so they can perform highly efficient linear movements with full controllability. The SRSA housing is made of steel for high stiffness and robustness. The wide range consists of cylinders with screw sizes from 39 mm up to 75 mm. This enables the use of electric SRSA cylinders in applications with peak forces up to 500 kN, where – in the past – only hydraulic cylinders were an option.

For long strokes, the free end of the screw shaft is supported and guided inside the push-tube to prevent any vibration.

The optional anti-rotation device is made of profile rail guides. This pre-loaded design provides very high torsional stiffness and durability.

Two internal bumpers secure the mechanism during the adjustment phase, protecting the screw nut from damage due to impact with the mechanical end stops.

For very high positioning accuracy, Ewellix offers the slow moving SVSA range with high precision recirculating roller-screws. Thanks to the very short screw lead of 1 mm only, it is easier to control the actuator while doing fine positioning adjustments.

High speed applications are covered with SRSA with speeds up to 1 111 mm/s and accelerations up to 38,2 m/s².

The full range of SRSA and SVSA is available in inline configurations as well as in parallel configurations to fit most applications.

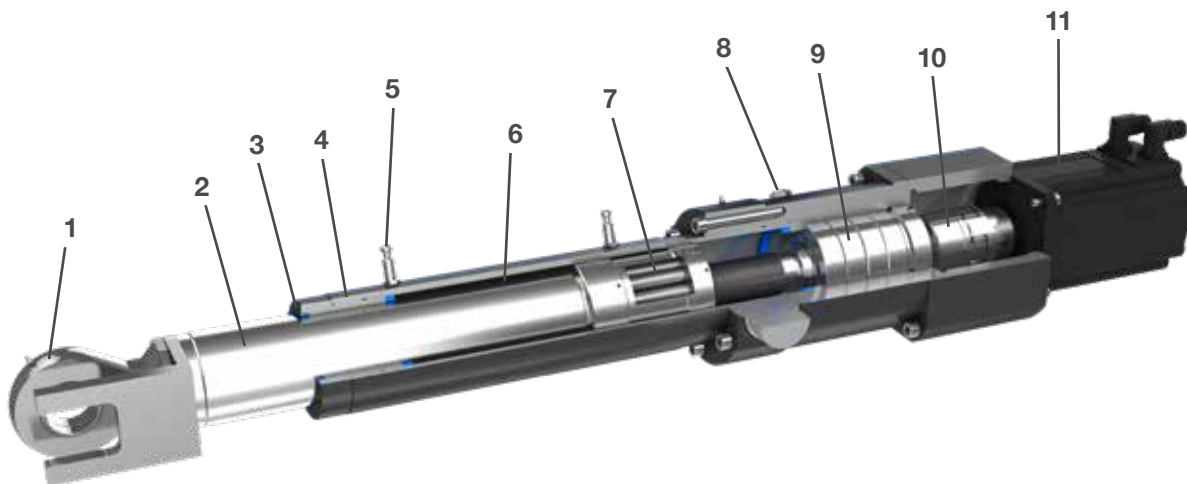

1. Rod end
2. Steel push tube
3. Scraper seal to protect against contaminants
4. Guiding bushing
5. Home and limit switches
6. Steel protection tube
7. High quality Ewellix planetary roller screw for highest axial loads with low play and high efficiency
8. Sinter filter for high airflow
9. High quality SKF angular contact ball bearings
10. Coupling
11. Servomotor

Motors and gearboxes

Servo motors

The SRSA can be ordered with a servo motor. In this case, Ewellix has selected a series of Lenze motors and drives that best matches the performance of the actuator to the end-user application. To complete the design, several options can be selected such as absolute encoder (EnDat, Hyperface), safety brake or associated servodrive. It is also possible to equip the SRSA with your preferred brand of servo motor so that it integrates best into your system. Please contact Ewellix to check the feasibility of your configuration. For more information, please visit the following sites:

Motors:

<http://www.lenze.com/en-us/products/motors/>

Drives:

<http://www.lenze.com/en-us/products/inverters/>

Drive options

The performance attributes shown in the table on the previous page are the result of specific Lenze servo motor and drive combinations. The SRSA can be offered with or without the servodrive. The servodrive can be in the recommended configuration or any other configuration that fits your installation.

In the case of a different combination, please contact Ewellix to determine what effect the different configuration will have on the performance of the actuator.

Performance overview of linear units

Linear unit	F_{max}	F_{max0}	V_{max}
SRSA-U-3905	150	150	342
SRSA-U-3910	150	150	683
SRSA-U-3915	150	150	1 025
SRSA-U-4805	260	260	278
SRSA-U-4810	260	260	556
SRSA-U-4815	260	260	833
SRSA-U-4820	260	260	1 111
SRSA-U-6010	370	370	444
SRSA-U-6015	370	370	667
SRSA-U-6020	370	370	889
SRSA-U-7510	500	500	356
SRSA-U-7515	500	500	533
SRSA-U-7520	500	500	711
SVSA-U-3201	60	60	10,4
SVSA-U-4001	80	80	8,3
SVSA-U-5001	175	175	6,7

Performance overview of actuators with servomotors

Linear unit	Interface and gear ratio	Motor	F _c	F _{co}	F _p	F _{pd}	V _{max}
–	–	–	kN	kN	kN	kN	mm/s
SRSA3905	L10/ P10	LC9	16,2	25,8 / 25	29,2	47,2 / 45,7	269
SRSA3905	L30/ P30	LA6	30,1	41,1 / 39,9	63,3	88,5 / 85,8	113
SRSA3905	L40/ P40	LA6	40,2	54,8 / 53,1	84,4	118 / 114,4	84
SRSA3910	L30/ P30	LC1	20,3	29,8 / 28,9	29,8	62,4 / 60,6	179
SRSA3910	L50/ P50	LC1	33,9	49,6 / 48,1	47,9	104,1 / 100,9	108
SRSA3910	L70/ P70	LC1	47,4	69,5 / 67,4	67,1	145,7 / 141,3	77
SRSA3915	L10/ P10	LB6	7,1	12 / 11,7	9,1	20,1 / 19,5	806
SRSA3915	L30/ P30	LD3	32,3	42,6 / 41,3	38,2	68,7 / 66,7	219
SRSA3915	L50/ P50	LD3	53,8	71 / 68,9	63,6	114,6 / 111,1	131
SRSA4805	L10/ P10	LD3	30,3	40 / 38,8	35,8	64,5 / 62,6	219
SRSA4805	L30/ P30	LD1	54,8	61,2 / 59,4	63,4	117,6 / 114,1	77
SRSA4805	L40/ P40	LD1	73,1	81,6 / 79,2	84,5	156,8 / 152,1	58
SRSA4810	L30/ P30	LD2	36,6	49,5 / 48	48,4	87 / 84,4	167
SRSA4810	L40/ P40	LD2	48,8	66 / 64,1	64,5	116 / 112,5	125
SRSA4810	L50/ P50	LD2	61	82,5 / 80,1	80,6	145 / 140,6	100
SRSA4815	L10/ P10	LD6	17,8	28,9 / 28,1	29,3	51,8 / 50,3	713
SRSA4815	L50/ P50	LD5	47,3	83,2 / 80,7	100,4	137,8 / 133,6	150
SRSA4815	L70/ P70	LD5	66,3	116,5 / 113	140,5	192,9 / 187,1	107
SRSA4820	L10/ P10	LD6	13,4	21,7 / 21,1	20,2	38,9 / 37,7	950
SRSA4820	L50/ P50	LD7	39,2	78,3 / 76	83,8	185,4 / 179,9	200
SRSA4820	L70/ P70	LD7	54,8	109,7 / 106,4	117,4	259,6 / 251,8	143
SRSA6010	L30/ P30	LD2	36,2	49 / 47,5	47,8	86 / 83,4	167
SRSA6010	L40/ P40	LD5	54,9	96,5 / 93,6	116,4	159,8 / 155	125
SRSA6010	L50/ P50	LD5	68,6	120,6 / 117	145,5	199,7 / 193,7	100
SRSA6015	L30/ P30	LD6	51,3	83,3 / 80,8	84,2	149,2 / 144,7	238
SRSA6015	L50/ P50	LD7	51,6	103,3 / 100,2	110,5	244,4 / 237,1	150
SRSA6015	L70/ P70	LD7	72,3	144,6 / 140,2	154,7	342,2 / 331,9	107
SRSA6020	L10/ P10	LD6	13,4	21,7 / 21,1	22	38,9 / 37,7	889
SRSA6020	L70/ P70	LD7	54,8	109,7 / 106,4	117,4	259,6 / 251,8	143
SRSA6020	L100/ P100	LD7	78,3	156,7 / 152	167,7	370,8 / 359,7	100
SRSA7510	L30/ P30	LD7	44,4	88,7 / 86,1	94,9	210 / 203,7	167
SRSA7510	L50/ P50	LD7	73,9	147,9 / 143,4	158,2	350 / 339,5	100
SRSA7510	L70/ P70	LD7	103,5	207 / 200,8	221,5	490 / 475,3	71
SRSA7515	L30/ P30	LD6	50,7	82,3 / 79,8	83,3	147,5 / 143,1	238
SRSA7515	L50/ P50	LD6	84,5	137,2 / 133,1	138,8	245,8 / 238,4	143
SRSA7515	L70/ P70	LD6	118,4	192,1 / 186,3	194,3	344,1 / 333,8	102
SRSA7520	L10/ P10	LD6	13,2	21,5 / 20,8	21,7	38,4 / 37,3	711
SRSA7520	L70/ P70	LD6	89,8	145,7 / 141,3	147,4	261,1 / 253,2	136
SRSA7520	L100/ P100	LD6	128,3	208,1 / 201,9	210,6	373 / 361,8	95
SVSA3201	L10/ P10	LC7	10,2	13,8 / 13,4	18,7	42,8 / 41,5	10
SVSA3201	L10/ P10	LD9	14,8	24,7 / 23,9	38,8	57,8 / 56,1	10
SVSA4001	L10/ P10	LA1	16,5	19,2 / 18,7	18,3	54,1 / 52,5	8
SVSA4001	L10/ P10	LA3	30,1	34,3 / 33,2	43,6	79,1 / 79,1	8
SVSA5001	L10/ P10	LA5	36	40 / 38,8	45,3	93 / 90,2	7
SVSA5001	L10/ P10	LE3	61,3	74,6 / 72,4	79,2	174,2 / 169,6	7

Standard motor types

Motor	Lenze servo motor	Lenze 9400 Highline servoamplifier
LA1	MCS12D20	E94ASHE0044
LA3	MCS12H15	E94ASHE0074
LA4	MCS12H35	E94ASHE0134
LA5	MCS12L20	E94ASHE0074
LA6	MCS12L41	E94ASHE0134
LB6	MCS14P32	E94ASHE0244
LC1	MCS14H32	E94ASHE0174
LC7	MCS09F38	E94ASHE0044
LC9	MCS14L32	E94ASHE0244
LD1	MCS14H28	E94ASHE0174
LD2	MCS14L30	E94ASHE0324
LD3	MCS14P26	E94ASHE0324
LD5	MCS19J30	E94ASHE0324
LD6	MCS19P29	E94ASHE0474
LD7	MCS19P30	E94ASHE0474
LD9	MCS09L41	E94ASHE0074
LE3	MCS14L15	E94ASHE0134

Manuals

Supporting documents are available for downloading on ewellix.com

3D Models

Product configurators for 3D models download are available on ewellix.com



SRSA, SVSA and SLSA operating manual

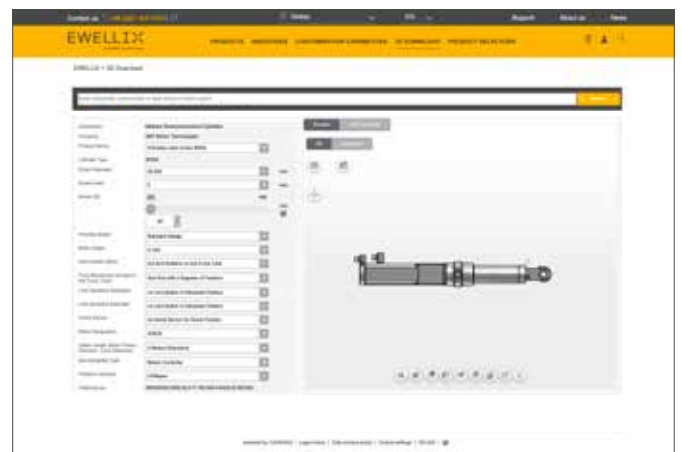

3D model configurator

SRSA-U-39xx

Linear unit



Technical data

Designation	Symbol	Unit	SRSA-U-3905	SRSA-U-3910	SRSA-U-3915
Performance Data					
Max. dynamic axial force	F_{max}	kN	150	150	150
Max. dynamic axial force L10 ¹⁾	F_{L10}	kN	90	90	90
Max. static axial force	F_{max0}	kN	150	150	150
Dynamic load capacity	C	kN	129	153	168
Maximum torque to reach F_{max}	M_{max}	Nm	159	301	446
Max. linear speed	v_{max}	mm/s	342	683	1 025
Max. rotational speed	n_{max}	1/min	4 100	4 100	4 100
Max. acceleration	a_{max}	m/s ²	9,5	19,1	28,6
Duty cycle	D_{unit}	%	100	100	100
Mechanical Data					
Screw type	–	–	Roller screw	Roller screw	Roller screw
Screw diameter	d_{screw}	mm	39	39	39
Screw lead	P_{screw}	mm	5	10	15
Lead accuracy	–	–	G5	G5	G5
Stroke ²⁾	s	mm	100...900	100...900	100...900
Internal overstroke each side	s_0	mm	5	5	5
Backlash ³⁾	$s_{backlash}$	mm	0	0	0
Efficiency	η_{lu}	%	75	79	80
Inertia @ 0 mm stroke	J_{lu}	10 ⁻⁴ kgm ²	21,3	21,3	21,3
Δ Inertia per 100 mm stroke	ΔJ	10 ⁻⁴ kgm ²	1,8	1,8	1,8
Weight @ 0 mm stroke	m_{lu}	kg	33,8	33,8	33,8
Δ weight per 100 mm stroke	Δm	kg	4,3	4,3	4,3
Weight of anti-rotation @ 0 mm stroke	m_{arot0}	kg	-0,3	-0,3	-0,3
Δ Weight of anti-rot. per 100 mm stroke	Δm_{arot}	kg	0,5	0,5	0,5
Environment					
Ambient temperature	$T_{ambient}$	°C	0...+40	0...+40	0...+40
Degree of protection ⁴⁾	IP	–	54	54	54

¹⁾ Maximum dynamic axial force usable to apply the theoretical lifetime calculation (L10)

²⁾ By 100 mm steps

³⁾ Backlash elimination up to stroke 600 mm. For longer strokes $s_{backlash} = 0,02$ mm for screw lead 5, 0,04 for lead 10, and 0,07 for lead 15

⁴⁾ With anti-rotation option IP44

Dimensional drawing

SRSA-U-39

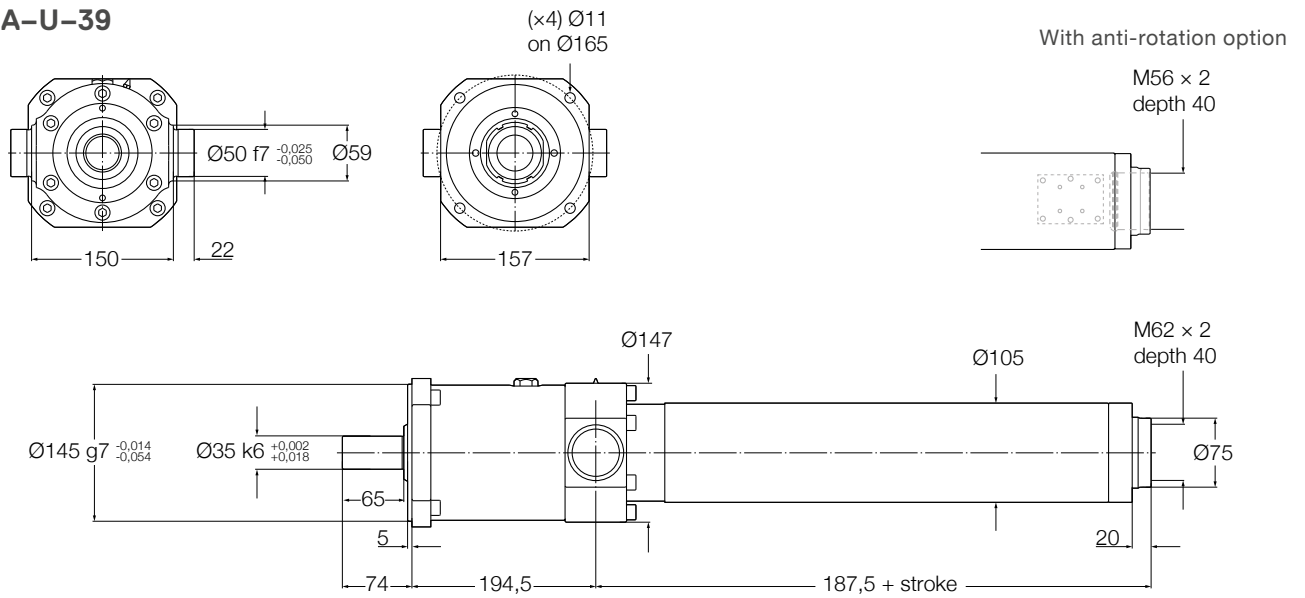

Performance diagrams

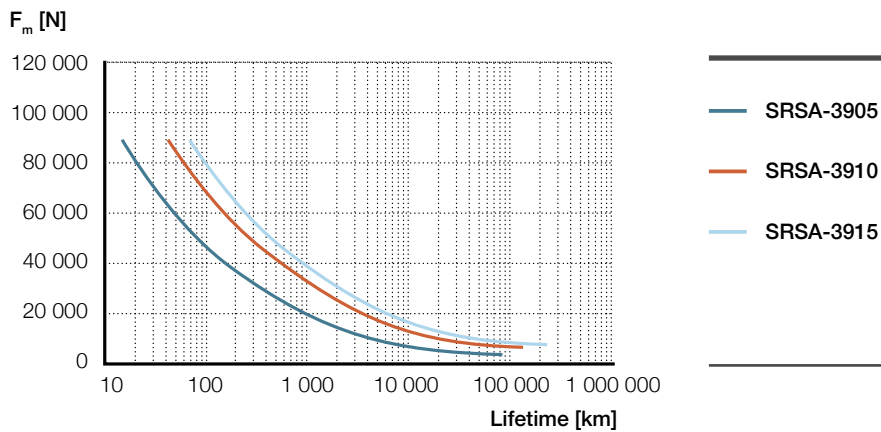

Ordering key

See page 18

SRSA-U-48xx

Linear unit



Technical data

Designation	Symbol	Unit	SRSA-U-4805	SRSA-U-4810	SRSA-U-4815	SRSA-U-4820
Performance Data						
Max. dynamic axial force	F_{max}	kN	260	260	260	260
Max. dynamic axial force L10 ¹⁾	F_{L10}	kN	140	140	140	140
Max. static axial force	F_{max0}	kN	260	260	260	260
Dynamic load capacity	C	kN	198	232	258	266
Maximum torque to reach F_{max}	M_{max}	Nm	283	527	773	1 031
Max. linear speed	v_{max}	mm/s	278	556	833	1 111
Max. rotational speed	n_{max}	1/min	3 333	3 333	3 333	3 333
Max. acceleration	a_{max}	m/s ²	9,5	19,1	28,6	38,2
Duty cycle	D_{unit}	%	100	100	100	100
Mechanical Data						
Screw type	–	–	Roller screw	Roller screw	Roller screw	Roller screw
Screw diameter	d_{screw}	mm	48	48	48	48
Screw lead	p_{screw}	mm	5	10	15	20
Lead accuracy	–	–	G5	G5	G5	G5
Stroke ²⁾	s	mm	100...1 200	100...1 200	100...1 200	100...1 200
Internal overstroke each side	s_0	mm	5	5	5	5
Backlash ³⁾	$s_{backlash}$	mm	0	0	0	0
Efficiency	η_{lu}	%	73%	79%	80%	80%
Inertia @ 0 mm stroke	J_{lu}	10 ⁻⁴ kgm ²	54,3	54,3	54,3	54,3
Δ Inertia per 100 mm stroke	ΔJ	10 ⁻⁴ kgm ²	4,1	4,1	4,1	4,1
Weight @ 0 mm stroke	m_{lu}	kg	53,2	53,2	53,2	53,2
Δ weight per 100 mm stroke	Δm	kg	5,7	5,7	5,7	5,7
Weight of anti-rotation @ 0 mm stroke	m_{arot0}	kg	3,6	3,6	3,6	3,6
Δ Weight of anti-rot. per 100 mm stroke	Δm_{arot}	kg	0,7	0,7	0,7	0,7
Environment						
Ambient temperature	$T_{ambient}$	°C	0...+40	0...+40	0...+40	0...+40
Degree of protection ⁴⁾	IP	–	54	54	54	54

¹⁾ Maximum dynamic axial force usable to apply the theoretical lifetime calculation (L10)

²⁾ By 100 mm steps

³⁾ Backlash elimination up to stroke 600 mm. For longer strokes $s_{backlash} = 0,02$ mm for screw lead 5, 0,04 for lead 10, and 0,07 for lead 15 & 20

⁴⁾ With anti-rotation option IP44

Dimensional drawing

SRSA-U-48

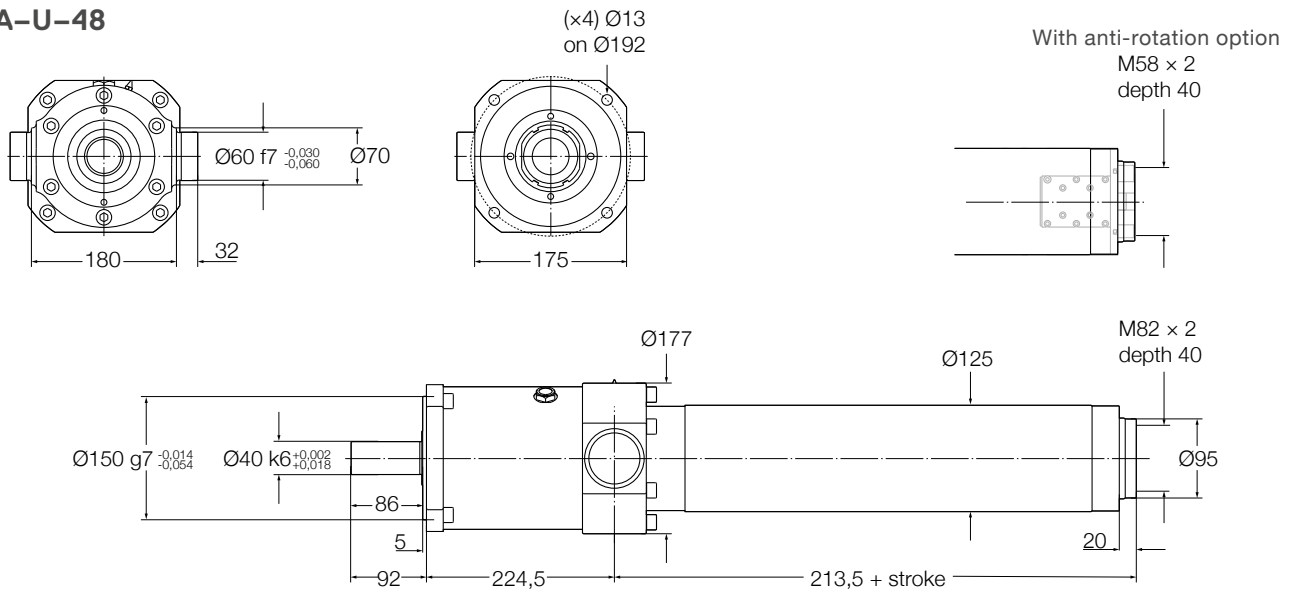

Performance diagrams

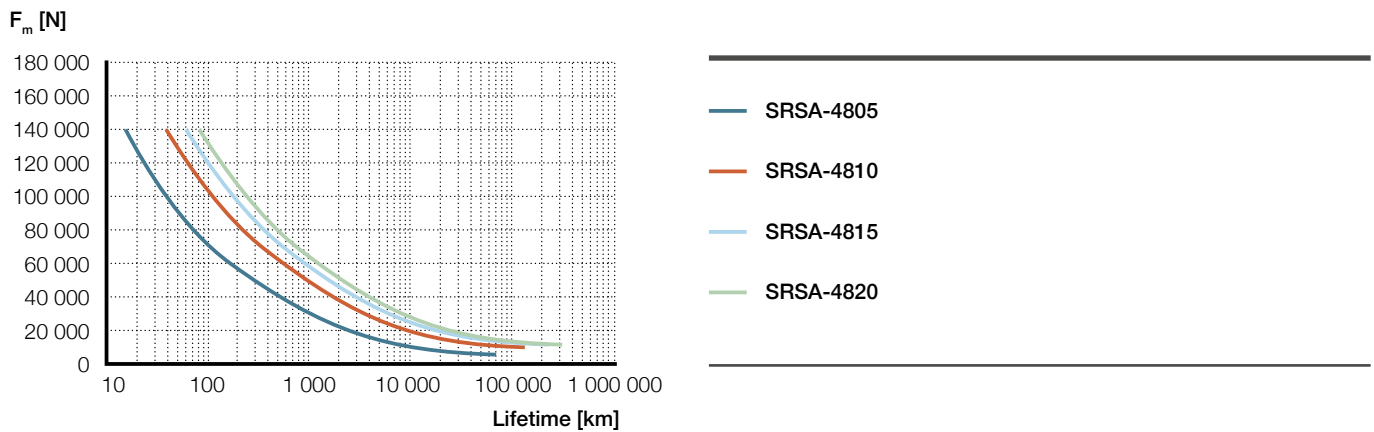

Ordering key

See page 18

SRSA-U-60xx

Linear unit



Technical data

Designation	Symbol	Unit	SRSA-U-6010	SRSA-U-6015	SRSA-U-6020
Performance Data					
Max. dynamic axial force	F_{max}	kN	370	370	370
Max. dynamic axial force L10 ¹⁾	F_{L10}	kN	250	250	250
Max. static axial force	F_{max0}	kN	370	370	370
Dynamic load capacity	C	kN	339	373	395
Maximum torque to reach F_{max}	M_{max}	Nm	759	1 112	1 467
Max. linear speed	v_{max}	mm/s	444	667	889
Max. rotational speed	n_{max}	1/min	2 667	2 667	2 667
Max. acceleration	a_{max}	m/s ²	19,1	28,6	38,2
Duty cycle	D_{unit}	%	100	100	100
Mechanical Data					
Screw type	–	–	Roller screw	Roller screw	Roller screw
Screw diameter	d_{screw}	mm	60	60	60
Screw lead	P_{screw}	mm	10	15	20
Lead accuracy	–	–	G5	G5	G5
Stroke ²⁾	s	mm	100...1 300	100...1 300	100...1 300
Internal overstroke each side	s_0	mm	10	10	10
Backlash ³⁾	$s_{backlash}$	mm	0	0	0
Efficiency	η_{lu}	%	78%	79%	80%
Inertia @ 0 mm stroke	J_{lu}	10 ⁻⁴ kgm ²	178	178	178
Δ Inertia per 100 mm stroke	ΔJ	10 ⁻⁴ kgm ²	10,1	10,1	10,1
Weight @ 0 mm stroke	m_{lu}	kg	83,6	83,6	83,6
Δ weight per 100 mm stroke	Δm	kg	8,9	8,9	8,9
Weight of anti-rotation @ 0 mm stroke	m_{arot0}	kg	5,2	5,2	5,2
Δ Weight of anti-rot. per 100 mm stroke	Δm_{arot}	kg	0,8	0,8	0,8
Environment					
Ambient temperature	$T_{ambient}$	°C	0...+40	0...+40	0...+40
Degree of protection ⁴⁾	IP	–	54	54	54

¹⁾ Maximum dynamic axial force usable to apply the theoretical lifetime calculation (L10)

²⁾ By 100 mm steps

³⁾ Backlash elimination up to stroke 800 mm. For longer strokes $s_{backlash} = 0,04$ mm for screw lead 10, and 0,07 for lead 15 & 20

⁴⁾ With anti-rotation option IP44

SRSA-U-75xx

Linear unit



Technical data

Designation	Symbol	Unit	SRSA-U-7510	SRSA-U-7515	SRSA-U-7520
Performance Data					
Max. dynamic axial force	F_{max}	kN	500	500	500
Max. dynamic axial force L10 ¹⁾	F_{L10}	kN	450	450	450
Max. static axial force	F_{max0}	kN	500	500	500
Dynamic load capacity	C	kN	505	561	572
Maximum torque to reach F_{max}	M_{max}	Nm	1 050	1 521	2 004
Max. linear speed	v_{max}	mm/s	356	533	711
Max. rotational speed	n_{max}	1/min	2 133	2 133	2 133
Max. acceleration	a_{max}	m/s ²	19,1	28,6	38,2
Duty cycle	D_{unit}	%	100	100	100
Mechanical Data					
Screw type	–	–	Roller screw	Roller screw	Roller screw
Screw diameter	d_{screw}	mm	75	75	75
Screw lead	P_{screw}	mm	10	15	20
Lead accuracy	–	–	G5	G5	G5
Stroke ²⁾	s	mm	100...1 500	100...1 500	100...1 500
Internal overstroke each side	s_0	mm	10	10	10
Backlash ³⁾	$s_{backlash}$	mm	0	0	0
Efficiency	η_{lu}	%	76%	79%	79%
Inertia @ 0 mm stroke	J_{lu}	10 ⁻⁴ kgm ²	625	625	625
Δ Inertia per 100 mm stroke	ΔJ	10 ⁻⁴ kgm ²	24,6	24,6	24,6
Weight @ 0 mm stroke	m_{lu}	kg	156,5	156,5	156,5
Δ weight per 100 mm stroke	Δm	kg	11,3	11,3	11,3
Weight of anti-rotation @ 0 mm stroke	m_{arot0}	kg	7,5	7,5	7,5
Δ Weight of anti-rot. per 100 mm stroke	Δm_{arot}	kg	2,7	2,7	2,7
Environment					
Ambient temperature	$T_{ambient}$	°C	0...+40	0...+40	0...+40
Degree of protection ⁴⁾	IP	–	54	54	54

¹⁾ Maximum dynamic axial force usable to apply the theoretical lifetime calculation (L10)

²⁾ By 100 mm steps

³⁾ Backlash elimination up to stroke 1 000 mm. For longer strokes $s_{backlash} = 0,04$ mm for screw lead 10, and 0,07 for lead 15 & 20

⁴⁾ With anti-rotation option IP44

Dimensional drawing

SRSA-U-75

With anti-rotation option

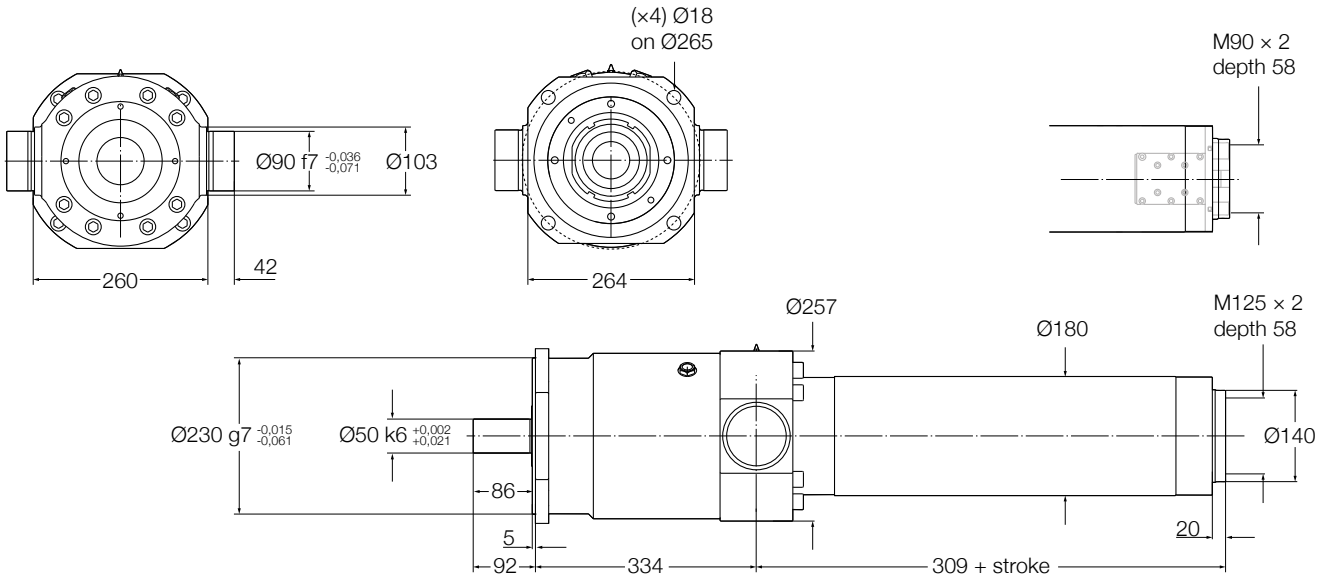

Performance diagrams

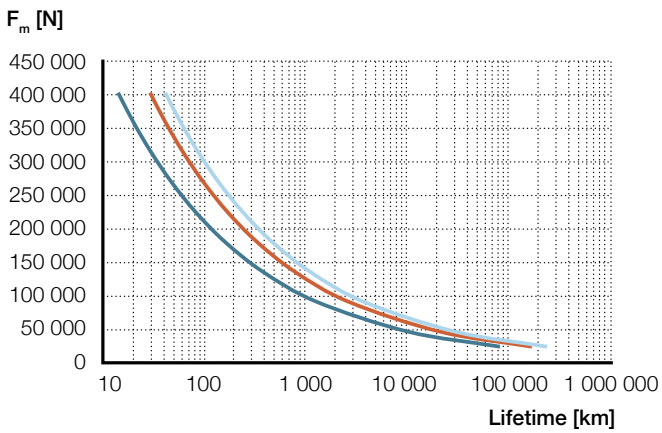

- SRSA-7510
- SRSA-7515
- SRSA-7520

Ordering key

See page 18

SVSA-U-xx01

Linear unit



Technical data

Designation	Symbol	Unit	SVSA-U-3201	SVSA-U-4001	SVSA-U-5001
Performance Data					
Max. dynamic axial force	F_{max}	kN	60	80	175
Max. dynamic axial force L10 ¹⁾	F_{L10}	kN	40	50	60
Max. static axial force	F_{max0}	kN	60	80	175
Dynamic load capacity	C	kN	64	79	174
Maximum torque to reach F_{max}	M_{max}	Nm	18,3	26,6	65,7
Max. linear speed	v_{max}	mm/s	10	8	7
Max. rotational speed	n_{max}	1/min	625	500	400
Max. acceleration	a_{max}	m/s ²	0,6	0,6	0,6
Duty cycle	D_{unit}	%	100	100	100
Mechanical Data					
Screw type	–	–	Roller screw	Roller screw	Roller screw
Screw diameter	d_{screw}	mm	32	40	50
Screw lead	p_{screw}	mm	1	1	1
Lead accuracy	–	–	G5	G5	G5
Stroke ²⁾	s	mm	100...600	100...800	100...900
Internal overstroke each side	s_0	mm	5	5	5
Backlash ³⁾	$s_{backlash}$	mm	0	0	0
Efficiency	η_{lu}	%	52	48	42
Inertia @ 0 mm stroke	J_{lu}	10 ⁻⁴ kgm ²	3,4	6,8	21,3
Δ Inertia per 100 mm stroke	ΔJ	10 ⁻⁴ kgm ²	0,31	0,64	1,8
Weight @ 0 mm stroke	m_{lu}	kg	10,8	17,4	34,2
Δ weight per 100 mm stroke	Δm	kg	2,4	3,2	4,8
Weight of anti-rotation @ 0 mm stroke	m_{arot0}	kg	2,6	-0,3	-0,3
Δ Weight of anti-rot. per 100 mm stroke	Δm_{arot}	kg	0,3	0,2	0,4
Environment					
Ambient temperature	$T_{ambient}$	°C	0...+40	0...+40	0...+40
Degree of protection ⁴⁾	IP	–	54	54	54

¹⁾ Maximum dynamic axial force usable to apply the theoretical lifetime calculation (L10)

²⁾ By 100 mm steps

³⁾ Backlash elimination up to stroke 600 mm. For longer strokes $s_{backlash} = 0,02$ mm

⁴⁾ With anti-rotation option IP44

Performance diagrams

F_m [N]

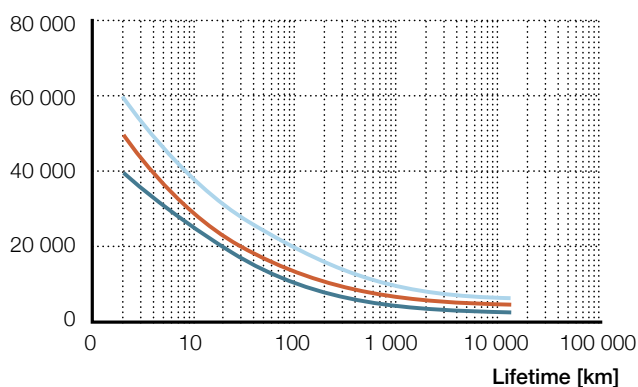

— SVSA-3201

— SVSA-4001

— SVSA-5001

Dimensional drawing

SVSA-U-3201

With anti-rotation option

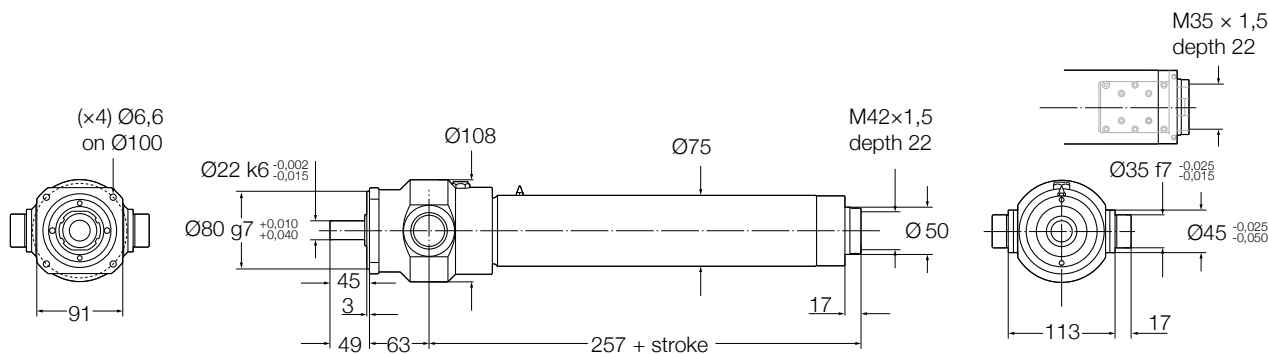

SVSA-U-4001

With anti-rotation option

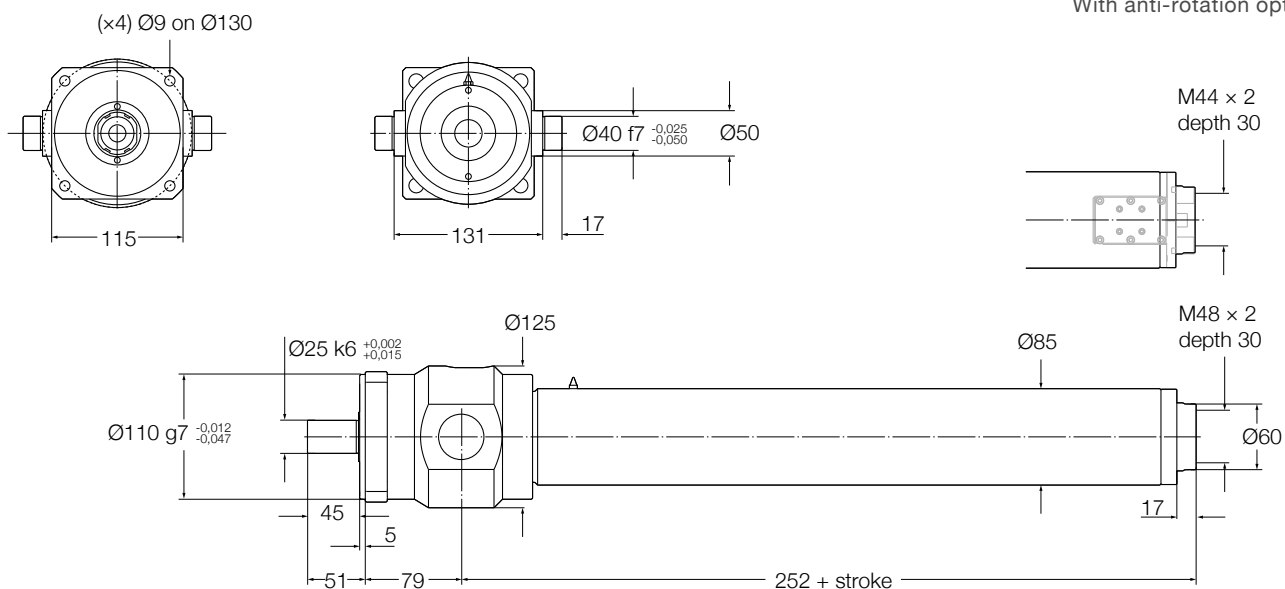

SVSA-U-5001

With anti-rotation option

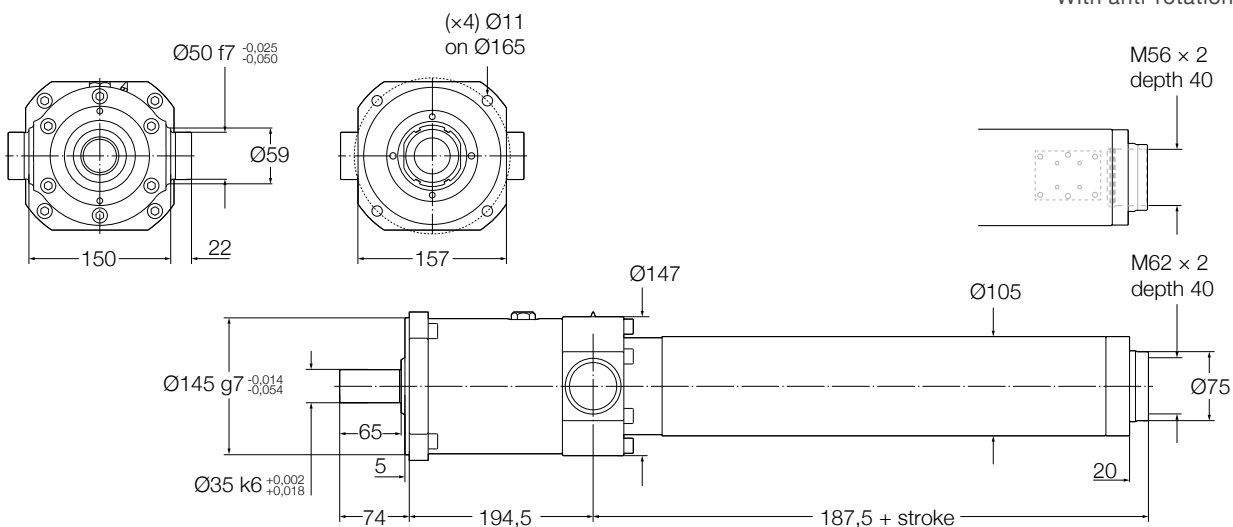

Ordering key

See page 18

Ordering key

Linear unit

S R S A - U - 4 8 1 0 - 0 2 0 0 - T R A F - N

Type

- R Planetary roller screw
- V Recirculating roller screw

Linear unit only

Screw diameter

- 39 Planetary roller screw
- 48 Planetary roller screw
- 60 Planetary roller screw
- 75 Planetary roller screw
- 32 Recirculating roller screw
- 40 Recirculating roller screw
- 50 Recirculating roller screw

Screw lead

- 5 only for Planetary roller screw
- 10 only for Planetary roller screw
- 15 only for Planetary roller screw
- 20 only for Planetary roller screw diameter 48, 60, 75
- 1 only for Recirculating roller screw

Stroke

Rear attachment

- T Trunnions
- Z Special
- N No attachment

Front attachment

- R Rod end
- F Rod end with fork
- Z Non standard
- N No attachment (female thread)

Anti-rotation

- A Anti-rotation
- N No anti-rotation

Limit switches

- F 2 limit switches and 1 home switch
- S 2 limit switches only
- M 1 limit switch and 1 home switch
- L 1 limit switch only
- H 1 home switch only
- N No switch

Motor interface

- N No interface
- L Inline interface (on request)
- P Parallel interface (on request)

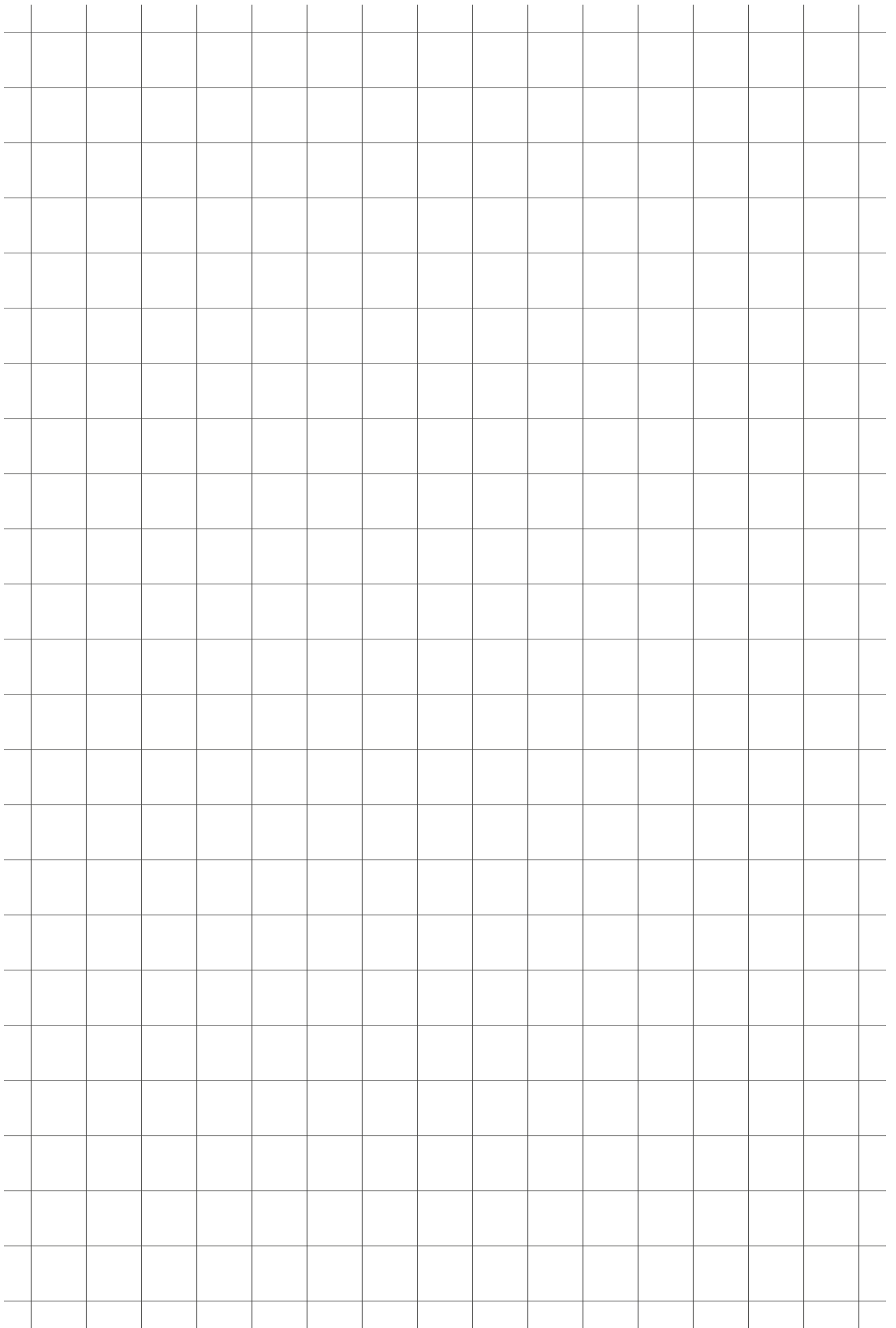

SRSA-S-39xx

Electric cylinder servo motor,
inline configuration



Technical data

Designation	Symbol	Unit	Servo motor and inline adapter		
			L30 LA6	L70 LC1	L30 LD3
Performance Data					
Continuous force @ zero speed	F_{c0}	kN	41,1	69,5	42,6
Continuous force @ max. speed	F_c	kN	30,1	47,4	32,3
Peak force @ zero speed	F_{p0}	kN	88,5	145,7	68,7
Peak force @ max. speed	F_p	kN	63,3	67,1	38,2
Dynamic load capacity	C	kN	129	153	168
Holding force (motorbrake option)	F_{Hold}	kN	58	115	32
Max. linear speed	v_{max}	mm/s	113	77	219
Max. acceleration	a_{max}	m/s ²	5,5	4,2	7,7
Duty cycle	D	%	100	100	100
Mechanical Data					
Screw type	–	–	Roller screw	Roller screw	Roller screw
Screw diameter	d_{screw}	mm	39	39	39
Screw lead	p_{screw}	mm	5	10	15
Lead accuracy	–	–	G5	G5	G5
Stroke ¹⁾	s	mm	100...900	100...900	100...900
Internal overstroke each side	s_0	mm	5	5	5
Backlash ²⁾	$s_{backlash}$	mm	0	0	0
Gear reduction	i		3	7	3
Inertia @ 0 mm stroke	J	10 ⁻⁴ kgm ²	15,36	23,05	72,65
Δ Inertia per 100 mm stroke	ΔJ	10 ⁻⁴ kgm ²	0,2	0,04	0,20
Inertia of optional brake	J_{brake}	10 ⁻⁴ kgm ²	1,07	3,20	3,20
Weight @ 0 mm stroke	m	kg	66,1	88,4	101,9
Δ weight per 100 mm stroke	Δm	kg	4,3	4,3	4,3
Weight of optional brake	m_{brake}	kg	0,9	1,9	1,9
Weight of anti-rotation @ 0 mm stroke	m_{arot0}	kg	-0,3	-0,3	-0,3
Δ Weight of anti-rot. per 100 mm stroke	Δm _{arot}	kg	0,5	0,5	0,5
Electrical Data					
Motor type	–	–	Servo	Servo	Servo
Nominal voltage	U	V AC	400	400	400
Nominal current	I	A	12,4	16,5	28,3
Peak current	I_{peak}	A	31,2	39,6	56
Nominal power	P	kW	4,67	4,73	9,07
Environment and Standards					
Ambient temperature	$T_{ambient}$	°C	0...+40	0...+40	0...+40
Degree of protection ³⁾	IP	–	54	54	54

¹⁾ By 100 mm steps

²⁾ Backlash elimination up to stroke 500 mm. For longer strokes $s_{backlash} = 0,02$ mm for screw lead 5, 0,04 for lead 10, and 0,07 for lead 15

³⁾ With anti-rotation option IP44

Dimensional drawing

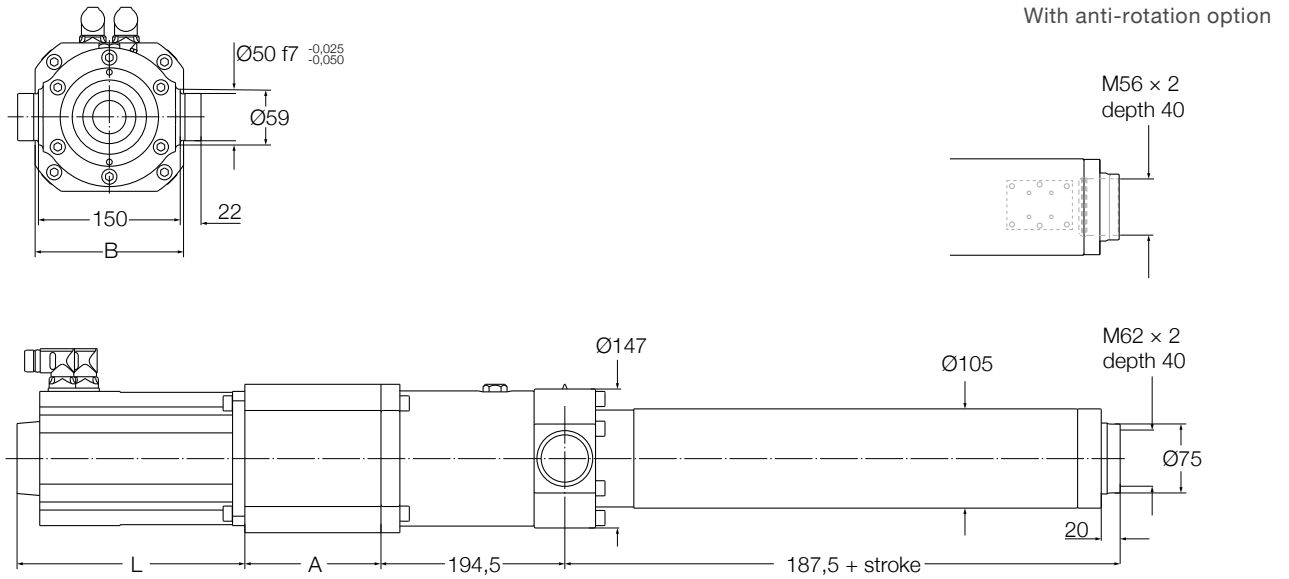

Reference	A	L	B	Added length for brake option	Added length for encoder option
-	mm				
L30LA6	186	415	185	20	49
L70LC1	216	455	185	28	50
L30LD3	216	584	185	28	50

Performance diagrams

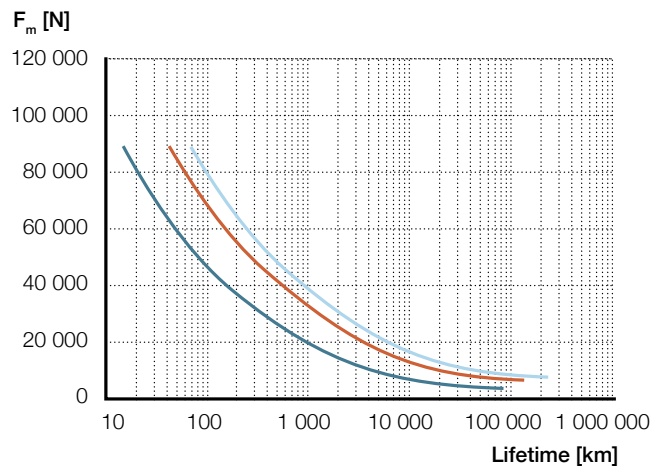
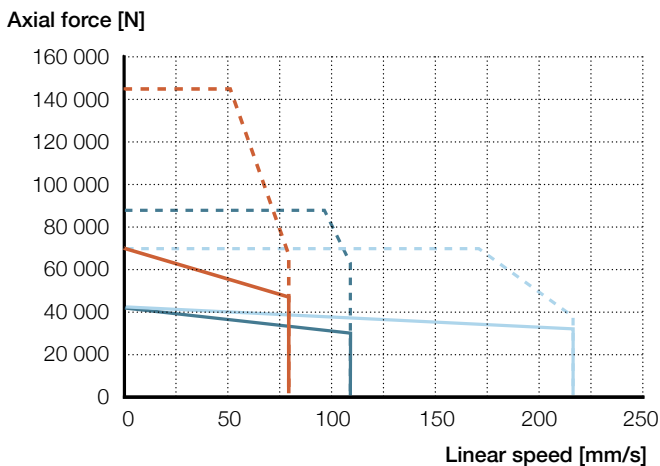

L30LA6	— F _{cont}	L70LC1	— F _{cont}	L30LD3	— F _{cont}
	- - - F _{peak}		- - - F _{peak}		- - - F _{peak}

— SRSA-3905	— SRSA-3910	— SRSA-3915
-------------	-------------	-------------

Ordering key

See page 42

SRSA-S-39xx

Electric cylinder servo motor,
parallel configuration



Technical data

Designation	Symbol	Unit	Servo motor and parallel adapter		
			P30 LA6	P70 LC1	P30 LD3
Performance Data					
Continuous force @ zero speed	F_{c0}	kN	39,9	67,4	41,3
Continuous force @ max. speed	F_c	kN	29,2	46	31,3
Peak force @ zero speed	F_{p0}	kN	85,8	141,3	66,7
Peak force @ max. speed	F_p	kN	61,4	65,1	37
Dynamic load capacity	C	kN	129	153	168
Holding force (motorbrake option)	F_{Hold}	kN	60	118	33
Max. linear speed	v_{max}	mm/s	113	77	219
Max. acceleration	a_{max}	m/s ²	1,6	0,5	4,3
Duty cycle	D	%	100	100	100
Mechanical Data					
Screw type	–	–	Roller screw	Roller screw	Roller screw
Screw diameter	d_{screw}	mm	39	39	39
Screw lead	p_{screw}	mm	5	10	15
Lead accuracy	–	–	G5	G5	G5
Stroke ¹⁾	s	mm	100...900	100...900	100...900
Internal overstroke each side	s_0	mm	5	5	5
Backlash ²⁾	$s_{backlash}$	mm	0	0	0
Gear reduction	i	–	3	7	3
Inertia @ 0 mm stroke	J	10 ⁻⁴ kgm ²	54,85	213,66	72,65
Δ Inertia per 100 mm stroke	ΔJ	10 ⁻⁴ kgm ²	0,2	0,04	0,20
Inertia of optional brake	J_{brake}	10 ⁻⁴ kgm ²	1,07	3,20	3,20
Weight @ 0 mm stroke	m	kg	76,3	97,6	101,9
Δ weight per 100 mm stroke	Δm	kg	4,3	4,3	4,3
Weight of optional brake	m_{brake}	kg	0,9	1,9	1,9
Weight of anti-rotation @ 0 mm stroke	m_{arot0}	kg	-0,3	-0,3	-0,3
Δ Weight of anti-rot. per 100 mm stroke	Δ m_{arot}	kg	0,5	0,5	0,5
Electrical Data					
Motor type	–	–	Servo	Servo	Servo
Nominal voltage	U	V AC	400	400	400
Nominal current	I	A	12,4	16,5	28,3
Peak current	I_{peak}	A	31,2	39,6	56
Nominal power	P	kW	4,67	4,73	9,07
Environment and Standards					
Ambient temperature	$T_{ambient}$	°C	0...+40	0...+40	0...+40
Degree of protection ³⁾	IP	–	54	54	54

¹⁾ By 100 mm steps

²⁾ Backlash elimination up to stroke 500 mm. For longer strokes $s_{backlash} = 0,02$ mm for screw lead 5, 0,04 for lead 10, and 0,07 for lead 15

³⁾ With anti-rotation option IP44

Dimensional drawing

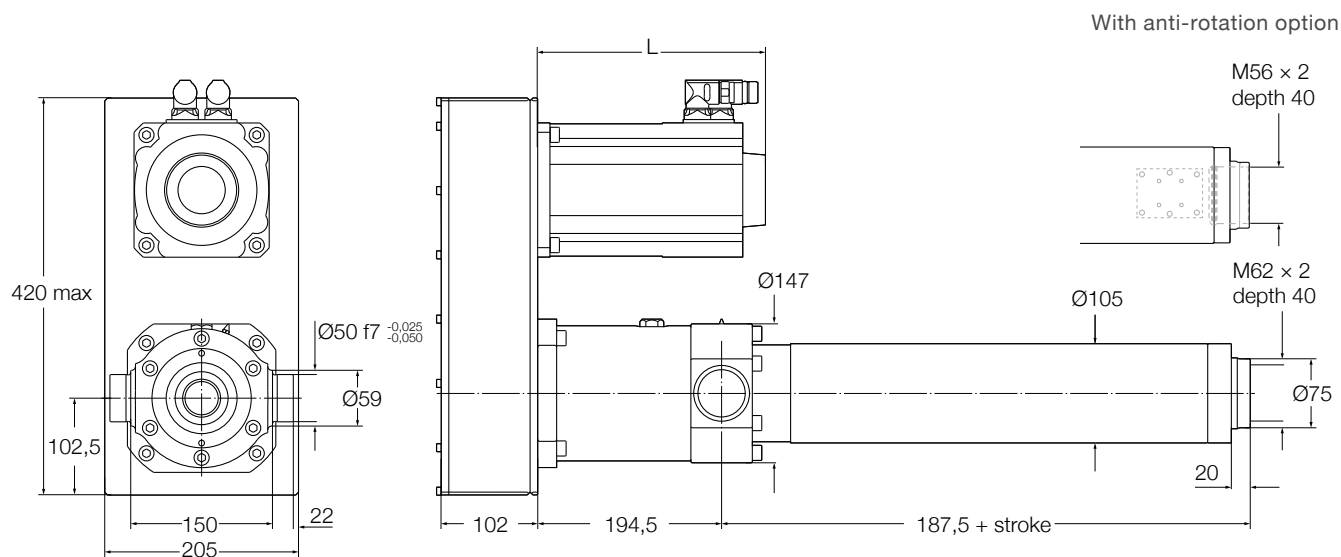

Reference	L mm	Added length for brake option	Added length for encoder option
-			
P30LA6	403	20	49
P70LC1	483	28	50
P30LD3	584	28	50

Performance diagrams

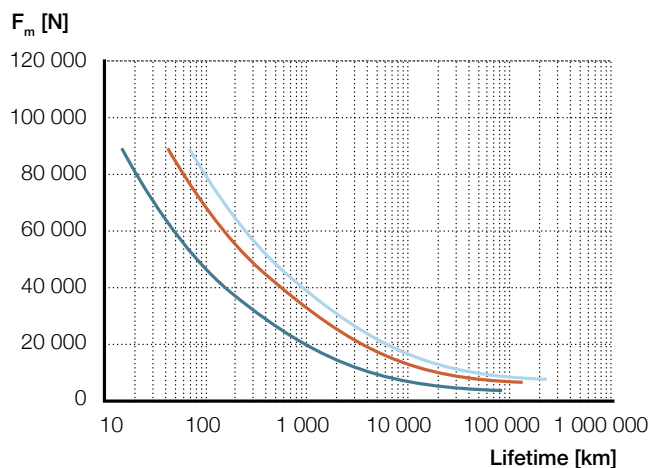
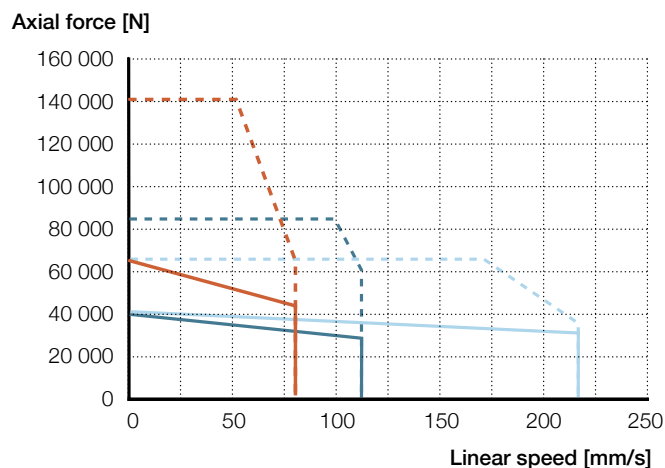

P30LA6	— F _{cont}	P70LC1	— F _{cont}	P30LD3	— F _{cont}
	- - - F _{peak}		- - - F _{peak}		- - - F _{peak}

— SRSA-3905	— SRSA-3910	— SRSA-3915
-------------	-------------	-------------

Ordering key

See page 42

SRSA-S-48xx

Electric cylinder
servo motor, inline configuration



Technical data

Designation	Symbol	Unit	Servo motor and inline adapter			
			L40 LD1	L50 LD2	L10 LD6	L70 LD7
Performance Data						
Continuous force @ zero speed	F_{c0}	kN	81,6	82,5	28,9	109,7
Continuous force @ max. speed	F_c	kN	73,1	61	17,8	54,8
Peak force @ zero speed	F_{p0}	kN	156,8	145	51,8	259,6
Peak force @ max. speed	F_p	kN	84,5	80,6	29,3	117,4
Dynamic load capacity	C	kN	198	232	258	261
Holding force (motorbrake option)	F_{Hold}	kN	150	84	18	95
Max. linear speed	v_{max}	mm/s	58	100	713	143
Max. acceleration	a_{max}	m/s ²	3,5	4,1	13	3,6
Duty cycle	D	%	100	100	100	100
Mechanical Data						
Screw type	–	–	Roller screw	Roller screw	Roller screw	Roller screw
Screw diameter	d_{screw}	mm	48	48	48	48
Screw lead	p_{screw}	mm	5	10	15	20
Lead accuracy	–	–	G5	G5	G5	G5
Stroke ¹⁾	s	mm	100...1 200	100...1 200	100...1 200	100...1 200
Internal overstroke each side	s_0	mm	5	5	5	5
Backlash ²⁾	$s_{backlash}$	mm	0	0	0	0
Gear reduction	i		4	5	1	7
Inertia @ 0 mm stroke	J	10 ⁻⁴ kgm ²	24,98	46,45	279,8	191,98
Δ Inertia per 100 mm stroke	ΔJ	10 ⁻⁴ kgm ²	0,26	0,16	4,12	0,08
Inertia of optional brake	J_{brake}	10 ⁻⁴ kgm ²	3,20	3,20	12,40	12,40
Weight @ 0 mm stroke	m	kg	109,1	126,6	128,8	168,2
Δ weight per 100 mm stroke	Δm	kg	5,7	5,7	5,7	5,7
Weight of optional brake	m_{brake}	kg	1,9	1,9	3,1	3,1
Weight of anti-rotation @ 0 mm stroke	m_{arot0}	kg	3,6	3,6	3,6	3,6
Δ Weight of anti-rot. per 100 mm stroke	Δ m_{arot}	kg	0,7	0,7	0,7	0,7
Electrical Data						
Motor type	–	–	Servo	Servo	Servo	Servo
Nominal voltage	U	V AC	400	400	400	400
Nominal current	I	A	16,5	26,7	44,7	34,9
Peak current	I_{peak}	A	39,6	56	94	94
Nominal power	P	kW	5,96	8,01	15,82	10,05
Environment and Standards						
Ambient temperature	$T_{ambient}$	°C	0...+40	0...+40	0...+40	0...+40
Degree of protection ³⁾	IP	–	54	54	54	54

¹⁾ By 100 mm steps

²⁾ Backlash elimination up to stroke 600 mm. For longer strokes $s_{backlash} = 0,02$ mm for screw lead 5, 0,04 mm for lead 10, and 0,07 for lead 15 & 20

³⁾ With anti-rotation option IP44

Dimensional drawing

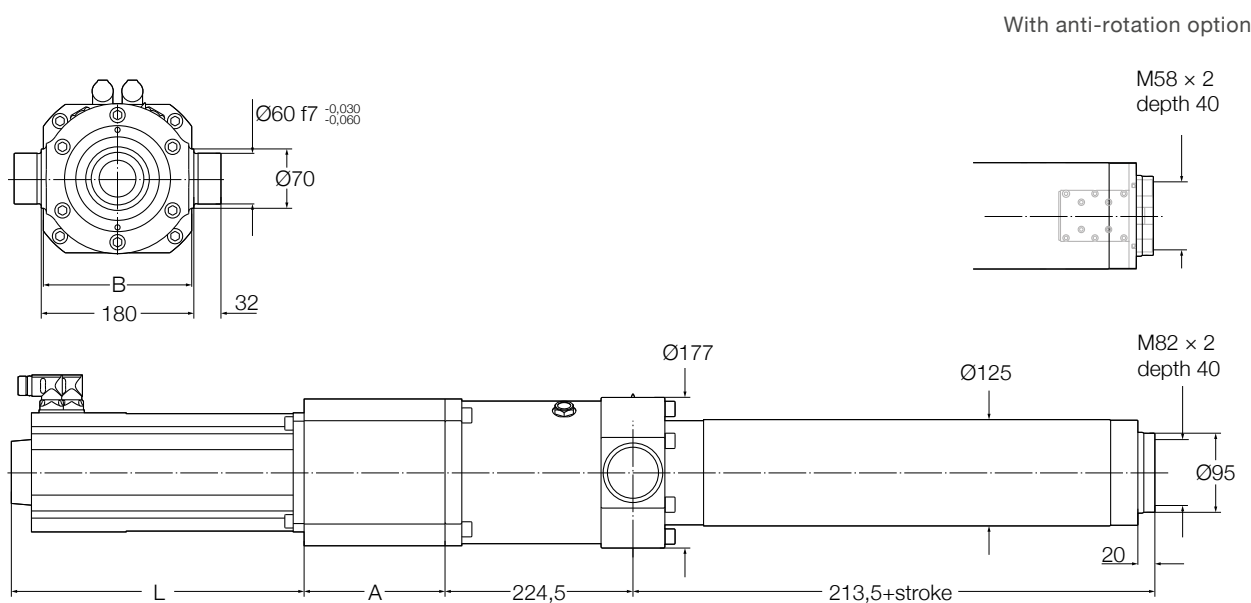

Reference	A	L	B	Added length for brake option	Added length for encoder option
-	mm				
L40LD1	206	476	192	28	50
L50LD2	239	544	192	28	50
L10LD6	178	427	192	44	49
L70LD7	247	529	192	44	49

Performance diagrams

Axial force [N]

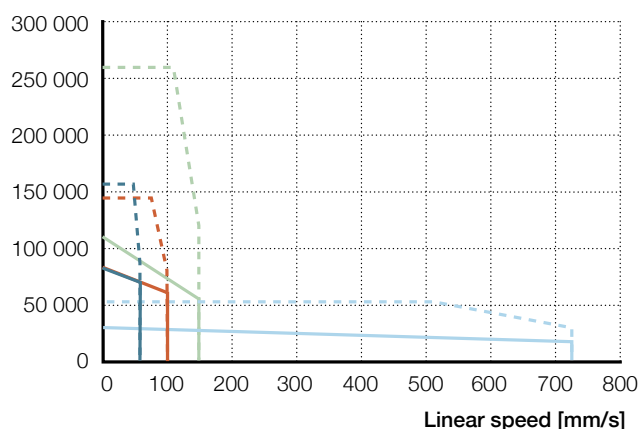

F_m [N]

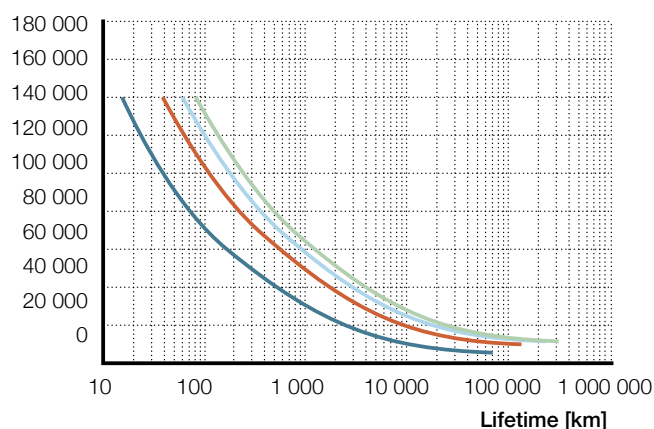

- | | | | | | |
|--------|-------|------------|--------|-------|------------|
| L40LD1 | — | F_{cont} | L50LD2 | — | F_{cont} |
| | - - - | F_{peak} | | - - - | F_{peak} |
| L10LD6 | — | F_{cont} | L70LD7 | — | F_{cont} |
| | - - - | F_{peak} | | - - - | F_{peak} |

- | | | | |
|---|-----------|---|-----------|
| — | SRSA-4805 | — | SRSA-4810 |
| — | SRSA-4815 | — | SRSA-4820 |

Ordering key

See page 42

SRSA-S-48xx

Electric cylinder servo motor,
parallel configuration



Technical data

Designation	Symbol	Unit	Servo motor and parallel adapter			
			P40 LD1	P50 LD2	P10 LD6	P70 LD7
Performance Data						
Continuous force @ zero speed	F_{c0}	kN	79,2	80,1	28,1	106,4
Continuous force @ max. speed	F_c	kN	70,9	59,2	17,3	53,2
Peak force @ zero speed	F_{p0}	kN	152,1	140,6	50,3	251,8
Peak force @ max. speed	F_p	kN	81,9	78,2	28,4	113,8
Dynamic load capacity	C	kN	198	232	258	261
Holding force (motorbrake option)	F_{Hold}	kN	155	86	18	98
Max. linear speed	v_{max}	mm/s	58	100	713	143
Max. acceleration	a_{max}	m/s ²	0,9	1,4	10,1	1
Duty cycle	D	%	100	100	100	100
Mechanical Data						
Screw type	–	–	Roller screw	Roller screw	Roller screw	Roller screw
Screw diameter	d_{screw}	mm	48	48	48	48
Screw lead	p_{screw}	mm	5	10	15	20
Lead accuracy	–	–	G5	G5	G5	G5
Stroke ¹⁾	s	mm	100...1 200	100...1 200	100...1 200	100...1 200
Internal overstroke each side	s_0	mm	5	5	5	5
Backlash ²⁾	$s_{backlash}$	mm	0	0	0	0
Gear reduction	i		4	5	1	7
Inertia @ 0 mm stroke	J	10 ⁻⁴ kgm ²	98,33	137,82	360,05	711,85
Δ Inertia per 100 mm stroke	ΔJ	10 ⁻⁴ kgm ²	0,26	0,16	4,12	0,08
Inertia of optional brake	J_{brake}	10 ⁻⁴ kgm ²	3,20	3,20	12,40	12,40
Weight @ 0 mm stroke	m	kg	114,6	126,3	134,6	174,6
Δ weight per 100 mm stroke	Δm	kg	5,7	5,7	5,7	5,7
Weight of optional brake	m_{brake}	kg	1,9	1,9	3,1	3,1
Weight of anti-rotation @ 0 mm stroke	m_{arot0}	kg	3,6	3,6	3,6	3,6
Δ Weight of anti-rot. per 100 mm stroke	Δ m_{arot}	kg	0,7	0,7	0,7	0,7
Electrical Data						
Motor type	–	–	Servo	Servo	Servo	Servo
Nominal voltage	U	V AC	400	400	400	400
Nominal current	I	A	16,5	26,7	44,7	34,9
Peak current	I_{peak}	A	39,6	56	94	94
Nominal power	P	kW	5,96	8,01	15,82	10,05
Environment and Standards						
Ambient temperature	$T_{ambient}$	°C	0...+40	0...+40	0...+40	0...+40
Degree of protection ³⁾	IP	–	54	54	54	54

¹⁾ By 100 mm steps

²⁾ Backlash elimination up to stroke 600 mm. For longer strokes $s_{backlash} = 0,02$ mm for screw lead 5, 0,04 mm for lead 10, and 0,07 for lead 15 & 20

³⁾ With anti-rotation option IP44

Dimensional drawing

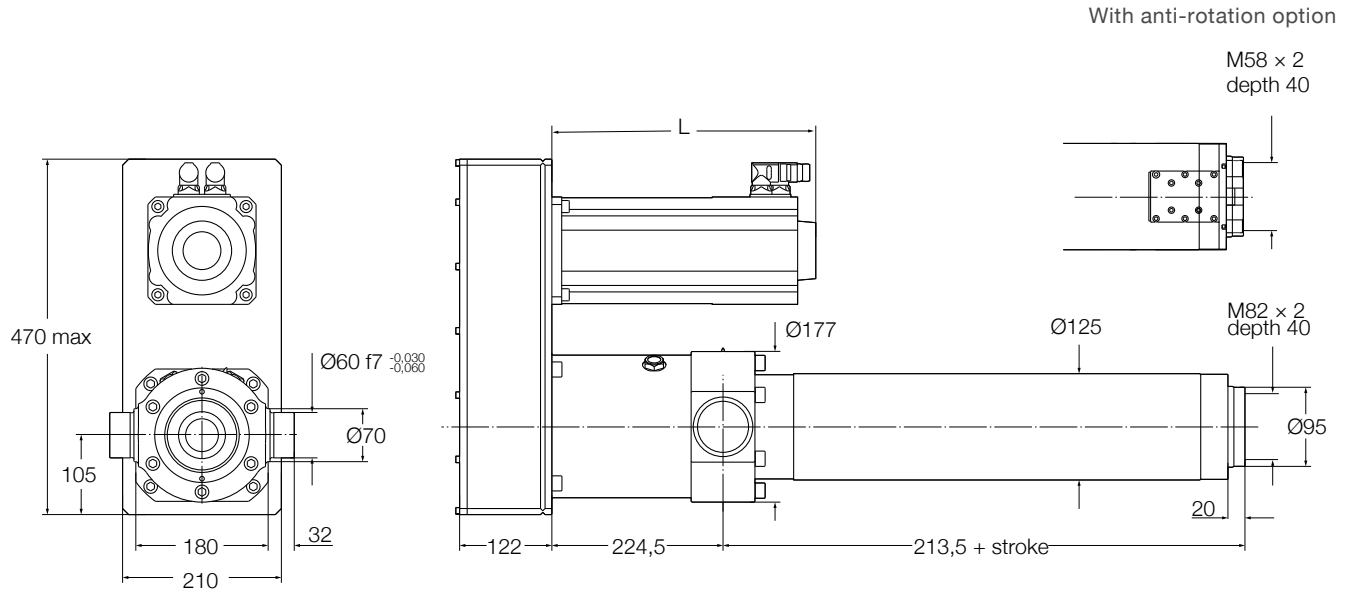

Reference	L mm	Added length for brake option	Added length for encoder option
-	-	-	-
P40LD1	476	28	50
P50LD2	544	28	50
P10LD6	427	44	49
P70LD7	529	44	49

Performance diagrams

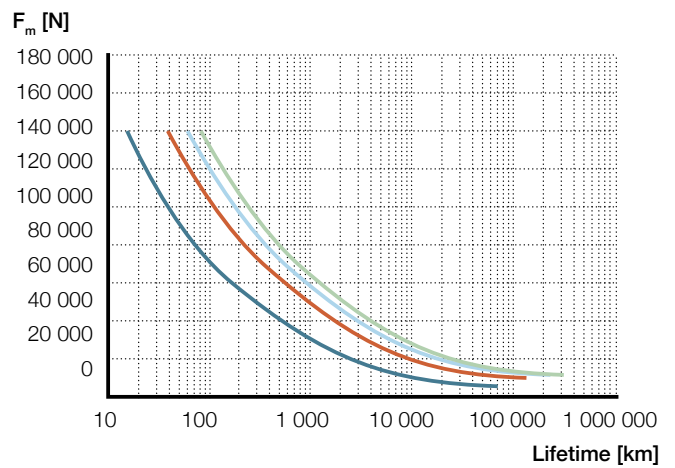
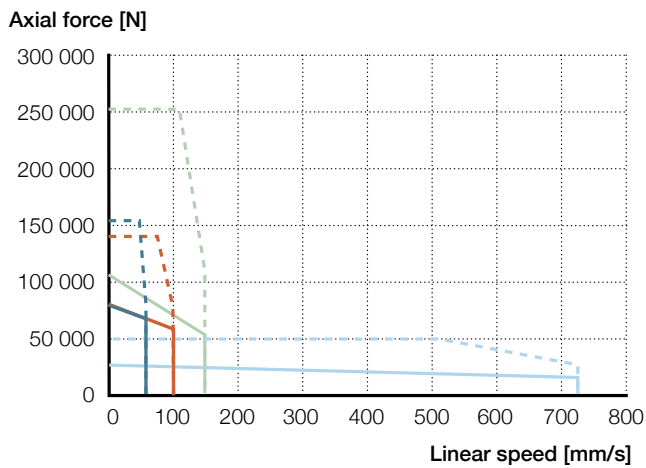

P40LD1 — F_{cont} (solid blue), F_{peak} (dashed blue)
P50LD2 — F_{cont} (solid orange), F_{peak} (dashed orange)
P10LD6 — F_{cont} (solid light blue), F_{peak} (dashed light blue)
P70LD7 — F_{cont} (solid green), F_{peak} (dashed green)

SRSA-4805 (solid dark blue), **SRSA-4810** (solid orange)
SRSA-4815 (solid light blue), **SRSA-4820** (solid green)

Ordering key

See page 42

SRSA-S-60xx

Electric cylinder servo motor,
inline configuration



Technical data

Designation	Symbol	Unit	Servo motor and inline adapter		
			L50	L30	L70
			LD5	LD6	LD7
Performance Data					
Continuous force @ zero speed	F_{c0}	kN	120,6	83,3	109,7
Continuous force @ max. speed	F_c	kN	68,6	51,3	54,8
Peak force @ zero speed	F_{p0}	kN	199,7	149,2	259,6
Peak force @ max. speed	F_p	kN	145,5	84,2	117,4
Dynamic load capacity	C	kN	339	373	395
Holding force (motorbrake option)	F_{Hold}	kN	144	55	95
Max. linear speed	v_{max}	mm/s	100	238	143
Max. acceleration	a_{max}	m/s ²	2	5,2	3,5
Duty cycle	D	%	100	100	100
Mechanical Data					
Screw type	–	–	Roller screw	Roller screw	Roller screw
Screw diameter	d_{screw}	mm	60	60	60
Screw lead	p_{screw}	mm	10	15	20
Lead accuracy	–	–	G5	G5	G5
Stroke ¹⁾	s	mm	100...1 300	100...1 300	100...1 300
Internal overstroke each side	s_0	mm	10	10	10
Backlash ²⁾	$s_{backlash}$	mm	0	0	0
Gear reduction	i		5	3	7
Inertia @ 0 mm stroke	J	10 ⁻⁴ kgm ²	134,01	236,18	194,51
Δ Inertia per 100 mm stroke	ΔJ	10 ⁻⁴ kgm ²	0,40	1,12	0,21
Inertia of optional brake	J_{brake}	10 ⁻⁴ kgm ²	12,40	12,40	12,40
Weight @ 0 mm stroke	m	kg	165,1	181,1	197,2
Δ weight per 100 mm stroke	Δm	kg	8,9	8,9	8,9
Weight of optional brake	m_{brake}	kg	3,1	3,1	3,1
Weight of anti-rotation @ 0 mm stroke	m_{arot0}	kg	5,2	5,2	5,2
Δ Weight of anti-rot. per 100 mm stroke	Δm _{arot}	kg	0,8	0,8	0,8
Electrical Data					
Motor type	–	–	Servo	Servo	Servo
Nominal voltage	U	V AC	400	400	400
Nominal current	I	A	30,5	44,7	34,9
Peak current	I_{peak}	A	56	94	94
Nominal power	P	kW	9,11	15,82	10,05
Environment and Standards					
Ambient temperature	$T_{ambient}$	°C	0...+40	0...+40	0...+40
Degree of protection ³⁾	IP	–	54	54	54

¹⁾ By 100 mm steps

²⁾ Backlash elimination up to stroke 800 mm. For longer strokes $s_{backlash} = 0,04$ mm for screw lead 10, and 0,07 for lead 15 & 20

³⁾ With anti-rotation option IP44

Dimensional drawing

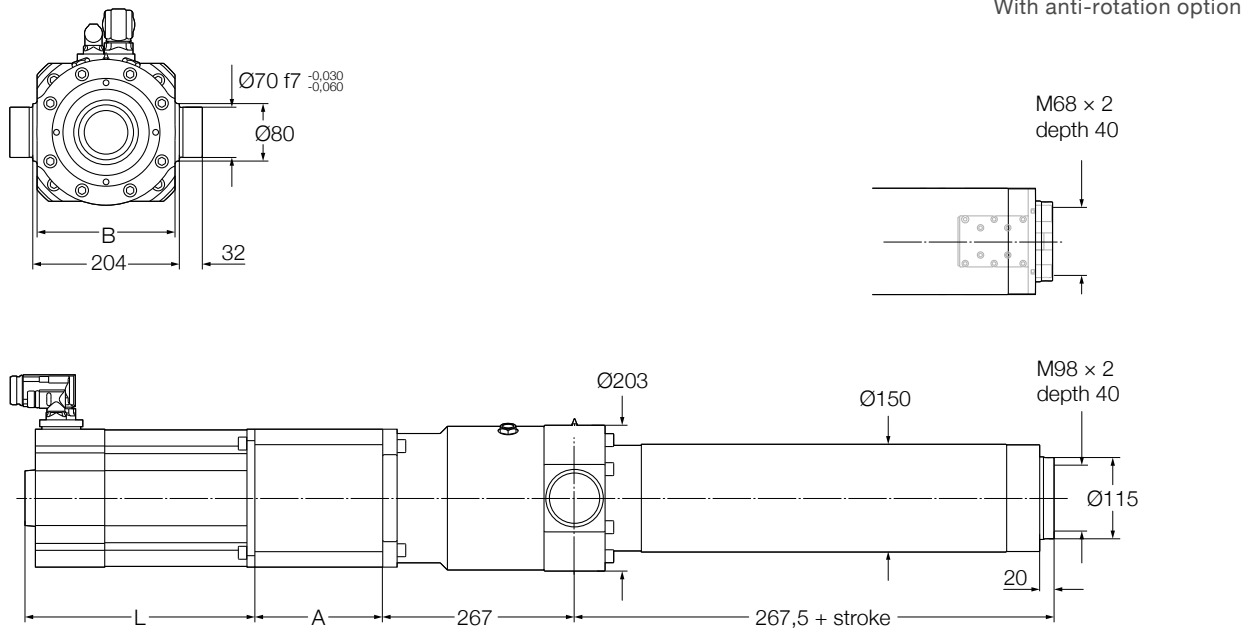

Reference	A	L	B	Added length for brake option	Added length for encoder option
-	mm				
L50LD5	240	435	192	44	49
L30LD6	240	602	192	44	49
L70LD7	248	529	192	44	49

Performance diagrams

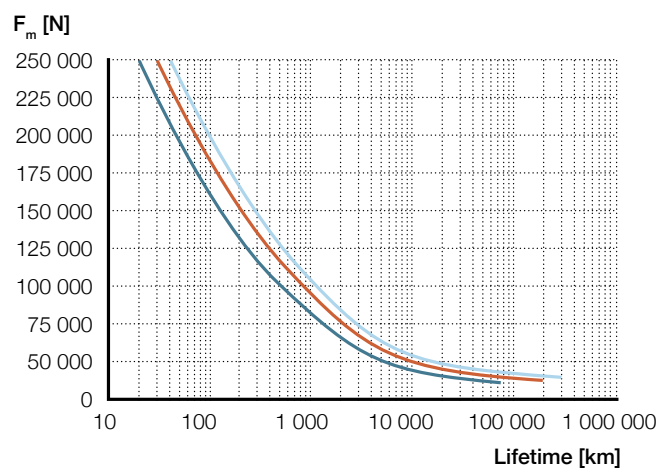
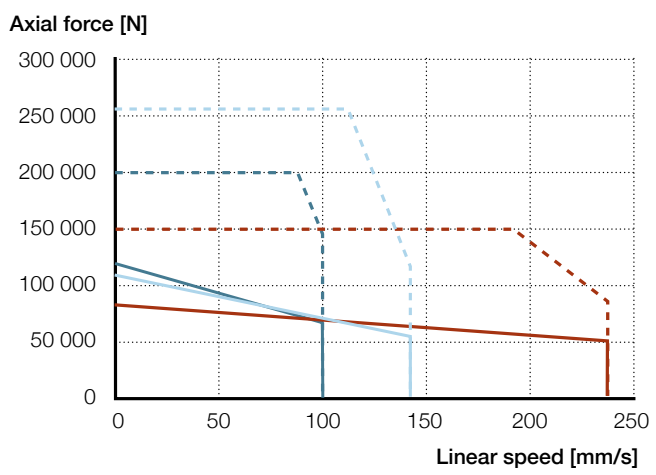

L50LD5 — F_{cont} **L30LD6** — F_{cont} **L70LD7** — F_{cont}
 - - - F_{peak} - - - F_{peak} - - - F_{peak}

— SRSA-6010 - - - SRSA-6015 - - - SRSA-6020

Ordering key

See page 42

SRSA-S-60xx

Electric cylinder servo motor,
parallel configuration



Technical data

Designation	Symbol	Unit	Servo motor and parallel adapter		
			P50 LD5	P30 LD6	P70 LD7
Performance Data					
Continuous force @ zero speed	F_{c0}	kN	117	80,8	106,4
Continuous force @ max. speed	F_c	kN	66,5	49,8	53,2
Peak force @ zero speed	F_{p0}	kN	193,7	144,7	251,8
Peak force @ max. speed	F_p	kN	141,1	81,7	113,8
Dynamic load capacity	C	kN	339	373	395
Holding force (motorbrake option)	F_{Hold}	kN	149	57	98
Max. linear speed	v_{max}	mm/s	100	238	143
Max. acceleration	a_{max}	m/s ²	0,6	2,2	1
Duty cycle	D	%	100	100	100
Mechanical Data					
Screw type	–	–	Roller screw	Roller screw	Roller screw
Screw diameter	d_{screw}	mm	60	60	60
Screw lead	p_{screw}	mm	10	15	20
Lead accuracy	–	–	G5	G5	G5
Stroke ¹⁾	s	mm	100...1 300	100...1 300	100...1 300
Internal overstroke each side	s_0	mm	10	10	10
Backlash ²⁾	$s_{backlash}$	mm	0	0	0
Gear reduction	i		5	3	7
Inertia @ 0 mm stroke	J	10 ⁻⁴ kgm ²	463,12	557,95	714,38
Δ Inertia per 100 mm stroke	ΔJ	10 ⁻⁴ kgm ²	0,40	1,12	0,21
Inertia of optional brake	J_{brake}	10 ⁻⁴ kgm ²	12,40	12,40	12,40
Weight @ 0 mm stroke	m	kg	173,3	187	206
Δ weight per 100 mm stroke	Δm	kg	8,9	8,9	8,9
Weight of optional brake	m_{brake}	kg	3,1	3,1	3,1
Weight of anti-rotation @ 0 mm stroke	m_{arot0}	kg	5,2	5,2	5,2
Δ Weight of anti-rot. per 100 mm stroke	Δ m_{arot}	kg	0,8	0,8	0,8
Electrical Data					
Motor type	–	–	Servo	Servo	Servo
Nominal voltage	U	V AC	400	400	400
Nominal current	I	A	30,5	44,7	34,9
Peak current	I_{peak}	A	56	94	94
Nominal power	P	kW	9,11	15,82	10,05
Environment and Standards					
Ambient temperature	$T_{ambient}$	°C	0...+40	0...+40	0...+40
Degree of protection ³⁾	IP	–	54	54	54

¹⁾ By 100 mm steps

²⁾ Backlash elimination up to stroke 800 mm. For longer strokes $s_{backlash} = 0,04$ mm for screw lead 10, and 0,07 for lead 15 & 20

³⁾ With anti-rotation option IP44

Dimensional drawing

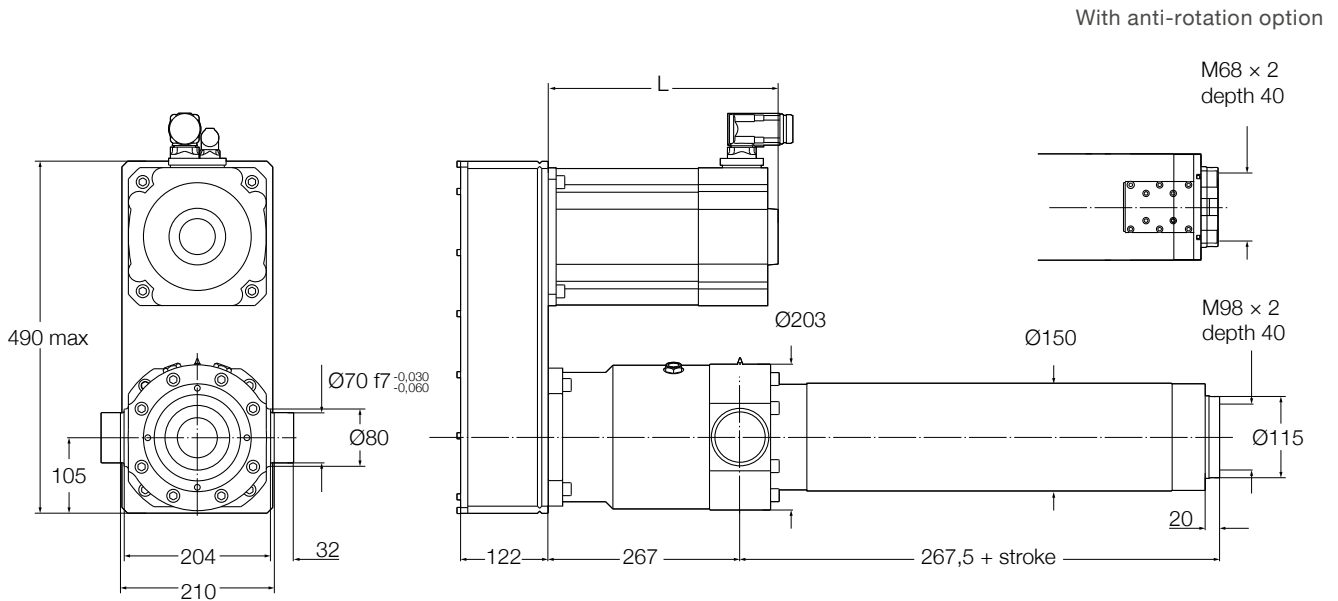

Reference	L mm	Added length for brake option	Added length for encoder option
-	-	-	-
P50LD5	435	44	49
P30LD6	602	44	49
P70LD7	529	44	49

Performance diagrams

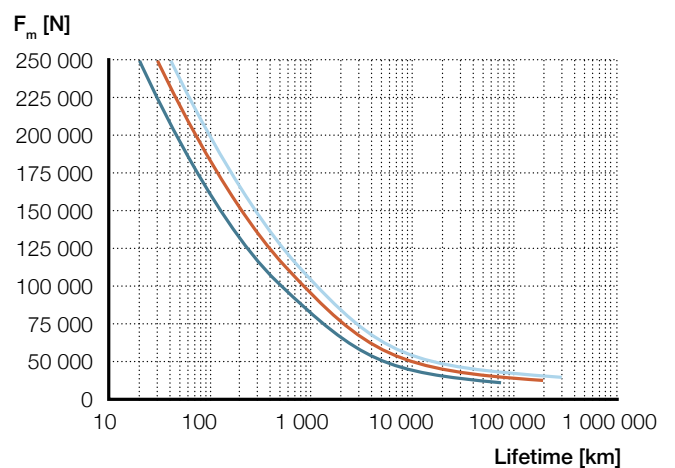
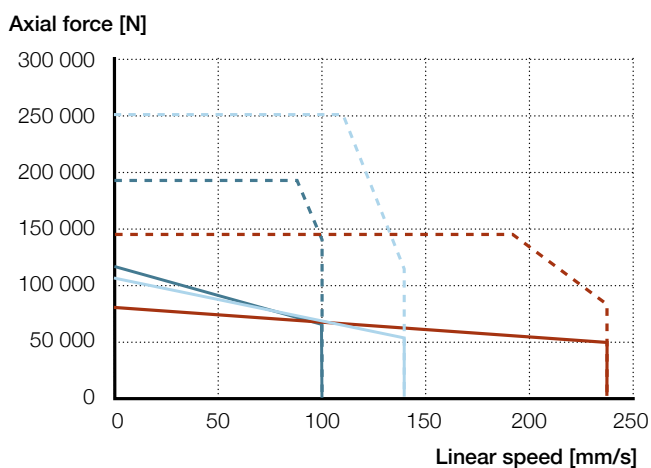

P50LD5	F_{cont}	P30LD6	F_{cont}	P70LD7	F_{cont}
	F_{peak}		F_{peak}		F_{peak}

SRSA-6010	SRSA-6015	SRSA-6020
-----------	-----------	-----------

Ordering key

See page 42

SRSA-S-75xx

Electric cylinder servo motor,
inline configuration



Technical data

Designation	Symbol	Unit	Servo motor and inline adapter		
			L70	L30	L70
			LD7	LD6	LD6
Performance Data					
Continuous force @ zero speed	F_{c0}	kN	207	82,3	145,7
Continuous force @ max. speed	F_c	kN	103,5	50,7	89,8
Peak force @ zero speed	F_{p0}	kN	490	147,5	261,1
Peak force @ max. speed	F_p	kN	221,5	83,3	147,4
Dynamic load capacity	C	kN	505	561	572
Holding force (motorbrake option)	F_{Hold}	kN	210	56	96
Max. linear speed	v_{max}	mm/s	71	238	136
Max. acceleration	a_{max}	m/s ²	1,7	4,3	3,4
Duty cycle	D	%	100	100	100
Mechanical Data					
Screw type	–	–	Roller screw	Roller screw	Roller screw
Screw diameter	d_{screw}	mm	75	75	75
Screw lead	p_{screw}	mm	10	15	20
Lead accuracy	–	–	G5	G5	G5
Stroke ¹⁾	s	mm	100...1 500	100...1 500	100...1 500
Internal overstroke each side	s_0	mm	10	10	10
Backlash ²⁾	$s_{backlash}$	mm	0	0	0
Gear reduction	i		7	3	7
Inertia @ 0 mm stroke	J	10 ⁻⁴ kgm ²	263,61	285,71	203,61
Δ Inertia per 100 mm stroke	ΔJ	10 ⁻⁴ kgm ²	0,50	2,73	0,44
Inertia of optional brake	J_{brake}	10 ⁻⁴ kgm ²	12,40	12,40	12,40
Weight @ 0 mm stroke	m	kg	292,1	277,8	298,1
Δ weight per 100 mm stroke	Δm	kg	11,3	11,3	11,3
Weight of optional brake	m_{brake}	kg	3,1	3,1	3,1
Weight of anti-rotation @ 0 mm stroke	m_{arot0}	kg	7,5	7,5	7,5
Δ Weight of anti-rot. per 100 mm stroke	Δ m_{arot}	kg	2,7	2,7	2,7
Electrical Data					
Motor type	–	–	Servo	Servo	Servo
Nominal voltage	U	V AC	400	400	400
Nominal current	I	A	34,9	44,7	44,7
Peak current	I_{peak}	A	94	94	94
Nominal power	P	kW	10,05	15,82	15,82
Environment and Standards					
Ambient temperature	$T_{ambient}$	°C	0...+40	0...+40	0...+40
Degree of protection ³⁾	IP	–	54	54	54

¹⁾ By 100 mm steps

²⁾ Backlash elimination up to stroke 1 000 mm. For longer strokes $s_{backlash} = 0,04$ mm for screw lead 10, and 0,07 for lead 15 & 20

³⁾ With anti-rotation option IP44

Dimensional drawing

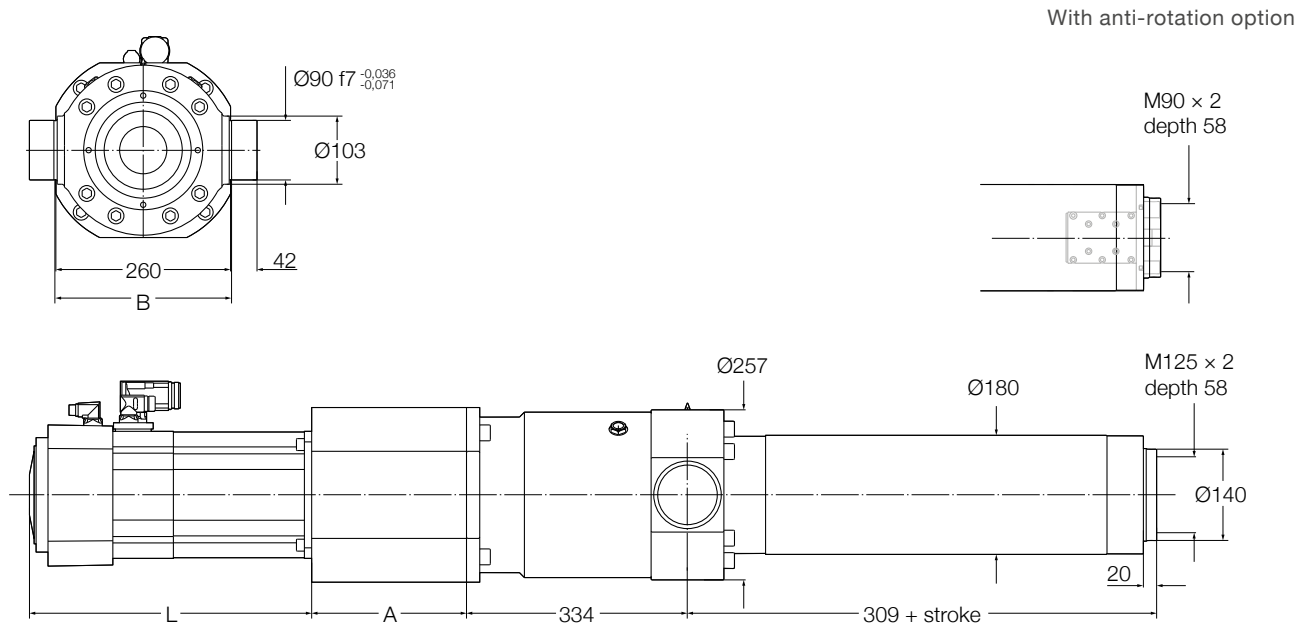

Reference	A	L	B	Added length for brake option	Added length for encoder option
-	mm				
L70LD7	247	529	264	44	49
L30LD6	239	602	264	44	49
L70LD6	247	636	264	44	49

Performance diagrams

Axial force [N]

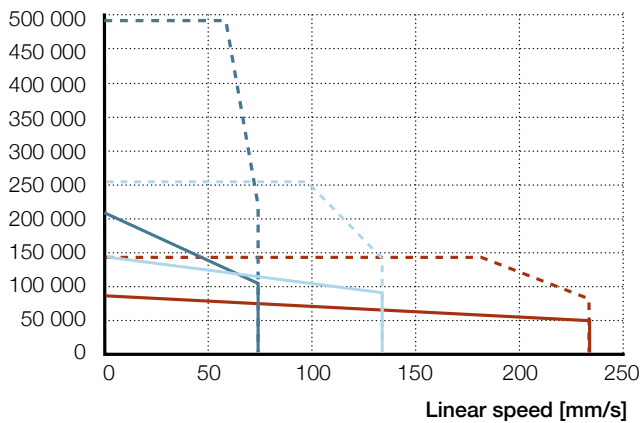

F_m [N]

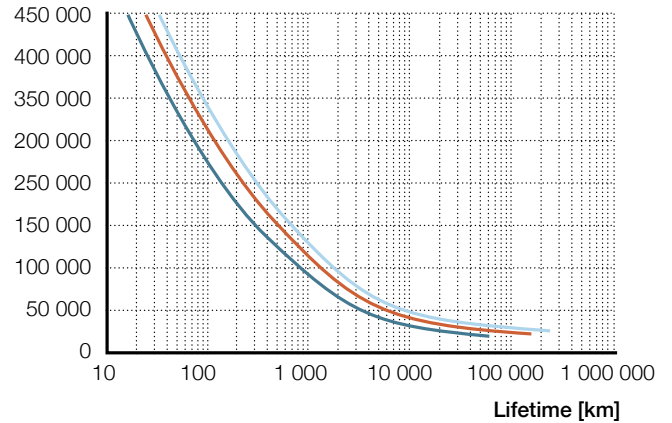

L70LD7	— F _{cont}	L30LD6	— F _{cont}	L70LD6	— F _{cont}
	- - - F _{peak}		- - - F _{peak}		- - - F _{peak}

— SRSA-7510	— SRSA-7515	— SRSA-7520
-------------	-------------	-------------

Ordering key

See page 42

SRSA-S-75xx

Electric cylinder servo motor,
parallel configuration



Technical data

Designation	Symbol	Unit	Servo motor and parallel adapter		
			P70 LD7	P30 LD6	P70 LD6
Performance Data					
Continuous force @ zero speed	F_{c0}	kN	200,8	79,8	141,3
Continuous force @ max. speed	F_c	kN	100,4	49,2	87,1
Peak force @ zero speed	F_{p0}	kN	475,3	143,1	253,2
Peak force @ max. speed	F_p	kN	214,9	80,8	143
Dynamic load capacity	C	kN	505	561	572
Holding force (motorbrake option)	F_{Hold}	kN	216	58	99
Max. linear speed	v_{max}	mm/s	71	238	136
Max. acceleration	a_{max}	m/s ²	0,5	2	1
Duty cycle	D	%	100	100	100
Mechanical Data					
Screw type	–	–	Roller screw	Roller screw	Roller screw
Screw diameter	d_{screw}	mm	75	75	75
Screw lead	p_{screw}	mm	10	15	20
Lead accuracy	–	–	G5	G5	G5
Stroke ¹⁾	s	mm	100...1 500	100...1 500	100...1 500
Internal overstroke each side	s_0	mm	10	10	10
Backlash ²⁾	$s_{backlash}$	mm	0	0	0
Gear reduction	i		7	3	7
Inertia @ 0 mm stroke	J	10 ⁻⁴ kgm ²	723,5	607,59	723,5
Δ Inertia per 100 mm stroke	ΔJ	10 ⁻⁴ kgm ²	0,50	2,73	0,44
Inertia of optional brake	J_{brake}	10 ⁻⁴ kgm ²	12,40	12,40	12,40
Weight @ 0 mm stroke	m	kg	303,5	284,6	309,5
Δ weight per 100 mm stroke	Δm	kg	11,3	11,3	11,3
Weight of optional brake	m_{brake}	kg	3,1	3,1	3,1
Weight of anti-rotation @ 0 mm stroke	m_{arot0}	kg	7,5	7,5	7,5
Δ Weight of anti-rot. per 100 mm stroke	Δ m_{arot}	kg	2,7	2,7	2,7
Electrical Data					
Motor type	–	–	Servo	Servo	Servo
Nominal voltage	U	V AC	400	400	400
Nominal current	I	A	34,9	44,7	44,7
Peak current	I_{peak}	A	94	94	94
Nominal power	P	kW	10,05	15,82	15,82
Environment and Standards					
Ambient temperature	$T_{ambient}$	°C	0...+40	0...+40	0...+40
Degree of protection ³⁾	IP	–	54	54	54

¹⁾ By 100 mm steps

²⁾ Backlash elimination up to stroke 1 000 mm. For longer strokes $s_{backlash} = 0,04$ mm for screw lead 10, and 0,07 for lead 15 & 20

³⁾ With anti-rotation option IP44

Dimensional drawing

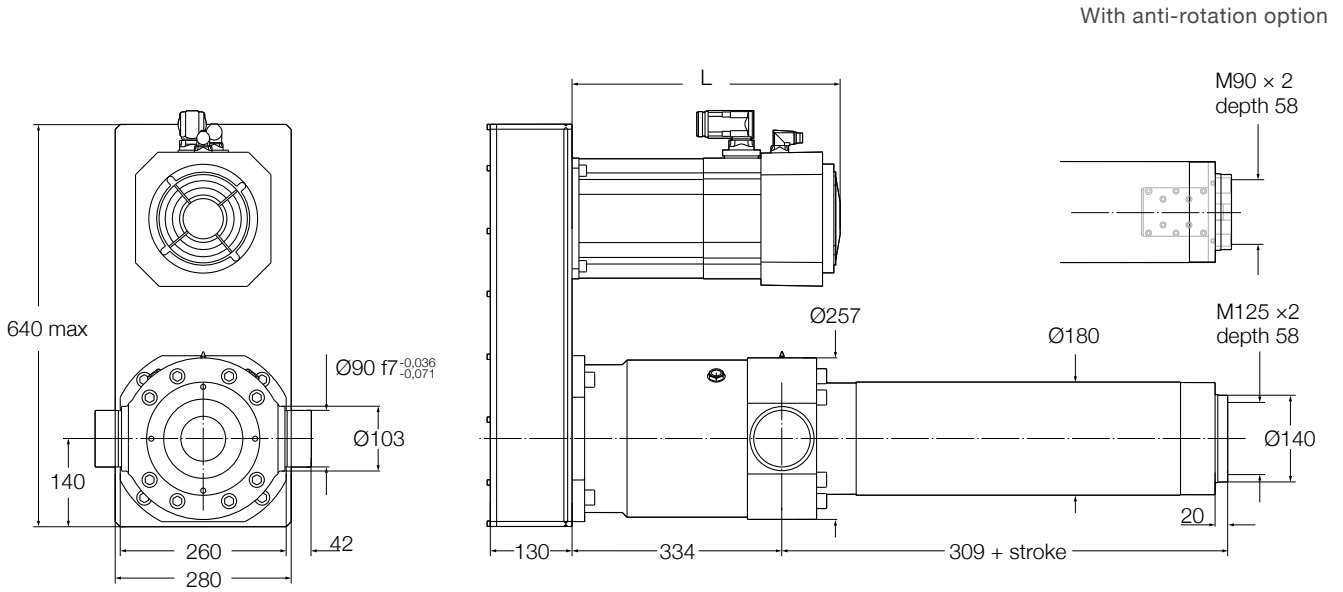

Reference	L mm	Added length for brake option	Added length for encoder option
-			
P70LD7	529	44	49
P30LD6	602	44	49
P70LD6	636	44	49

Performance diagrams

Axial force [N]

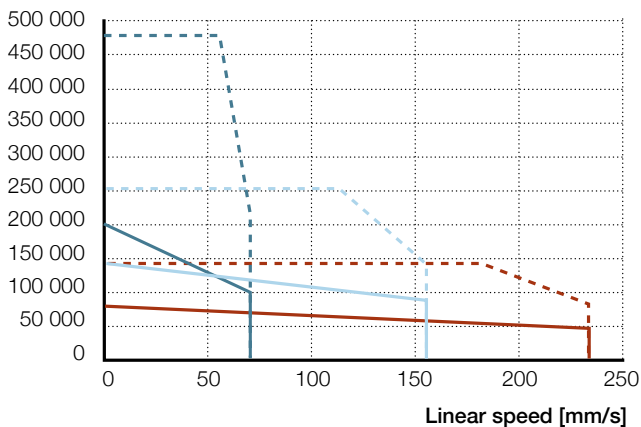

F_m [N]

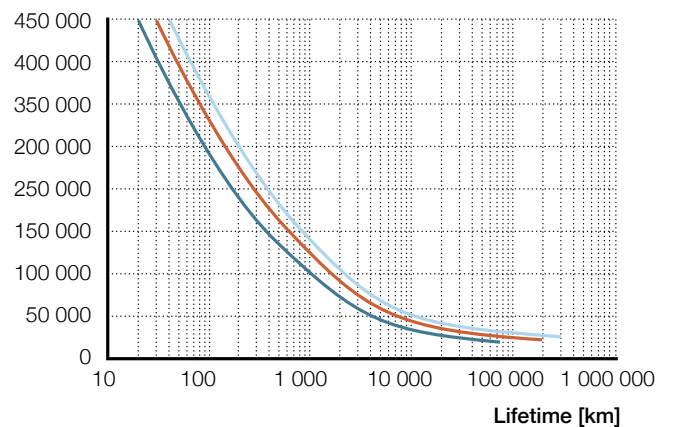

P70LD7	— F _{cont}	P30LD6	— F _{cont}	P70LD6	— F _{cont}
	- - - F _{peak}		- - - F _{peak}		- - - F _{peak}

— SRSA-7510	— SRSA-7515	— SRSA-7520
-------------	-------------	-------------

Ordering key

See page 42

SVSA-S-xx01

Electric cylinder servo motor,
inline configuration



Technical data

Designation	Symbol	Unit	Servo motor and inline adapter		
			L10 LC7	L10 LA1	L10 LA5
Performance Data					
Continuous force @ zero speed	F_{c0}	kN	13,8	19,2	40
Continuous force @ max. speed	F_c	kN	10,2	16,5	36
Peak force @ zero speed	F_{p0}	kN	42,8	54,1	93
Peak force @ max. speed	F_p	kN	18,7	18,3	45,3
Dynamic load capacity	C	kN	64	79	174
Holding force (motorbrake option)	F_{Hold}	kN	64	79,0	174
Max. linear speed	v_{max}	mm/s	10,4	8,3	6,7
Max. acceleration	a_{max}	m/s ²	0,6	0,6	0,6
Duty cycle	D	%	100	100	100
Mechanical Data					
Screw type	–	–	Roller screw	Roller screw	Roller screw
Screw diameter	d_{screw}	mm	32	40	50
Screw lead	p_{screw}	mm	1	1	1
Lead accuracy	–	–	G5	G5	G5
Stroke ¹⁾	s	mm	100...600	100...800	100...900
Internal overstroke each side	s_0	mm	5	5	5
Backlash ³⁾	$s_{backlash}$	mm	0	0	0
Gear reduction	i		1	1	1
Inertia @ 0 mm stroke	J	10 ⁻⁴ kgm ²	8,88	19,95	40,82
Δ Inertia per 100 mm stroke	ΔJ	10 ⁻⁴ kgm ²	0,31	0,64	1,8
Inertia of optional brake	J_{brake}	10 ⁻⁴ kgm ²	1,07	1,07	1,07
Weight @ 0 mm stroke	m	kg	19,1	30,1	62,4
Δ weight per 100 mm stroke	Δm	kg	2,4	3,2	4,8
Weight of optional brake	m_{brake}	kg	0,8	0,9	0,9
Weight of anti-rotation @ 0 mm stroke	m_{arot0}	kg	2,6	-0,3	-0,3
Δ Weight of anti-rot. per 100 mm stroke	Δ m_{arot}	kg	0,3	0,2	0,4
Electrical Data					
Motor type	–	–	Servo	Servo	Servo
Nominal voltage	U	V AC	400	400	400
Nominal current	I	A	3	2,7	6,2
Peak current	I_{peak}	A	12,8	10	26,8
Nominal power	P	kW	1,22	1,12	2,76
Environment and Standards					
Ambient temperature	$T_{ambient}$	°C	0...+40	0...+40	0...+40
Degree of protection ²⁾	IP	–	54	54	54

¹⁾ By 100 mm steps

²⁾ With anti-rotation option IP44

³⁾ Backlash elimination up to stroke 600 mm. For longer strokes $s_{backlash} = 0,02$ mm

Dimensional drawing

SVSA-S-3201

With anti-rotation option

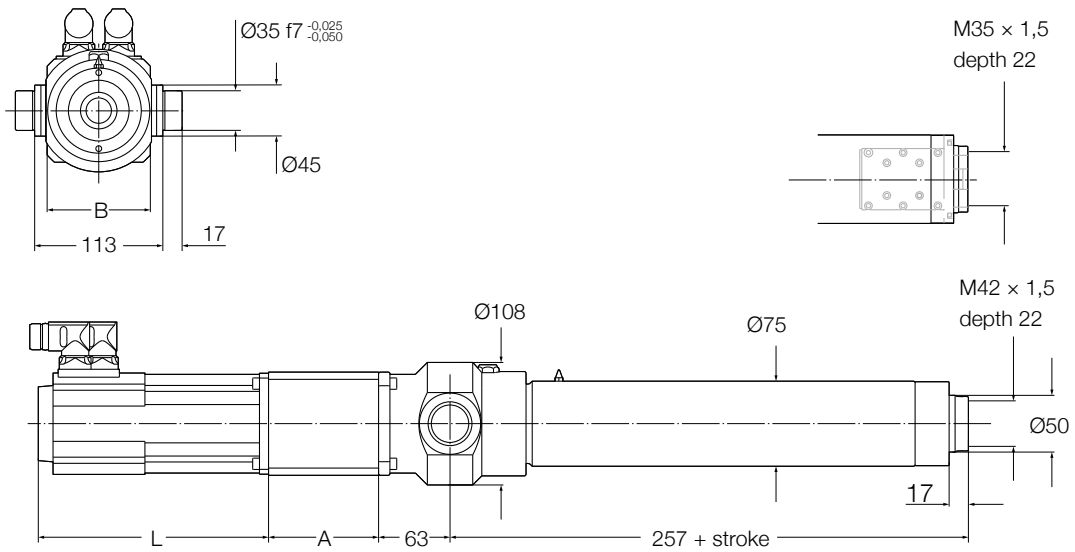

Reference	A	L	B	Added length for brake option	Added length for encoder option
-	mm				
L10LC7	97	203	91	20	51

SVSA-S-4001

With anti-rotation option

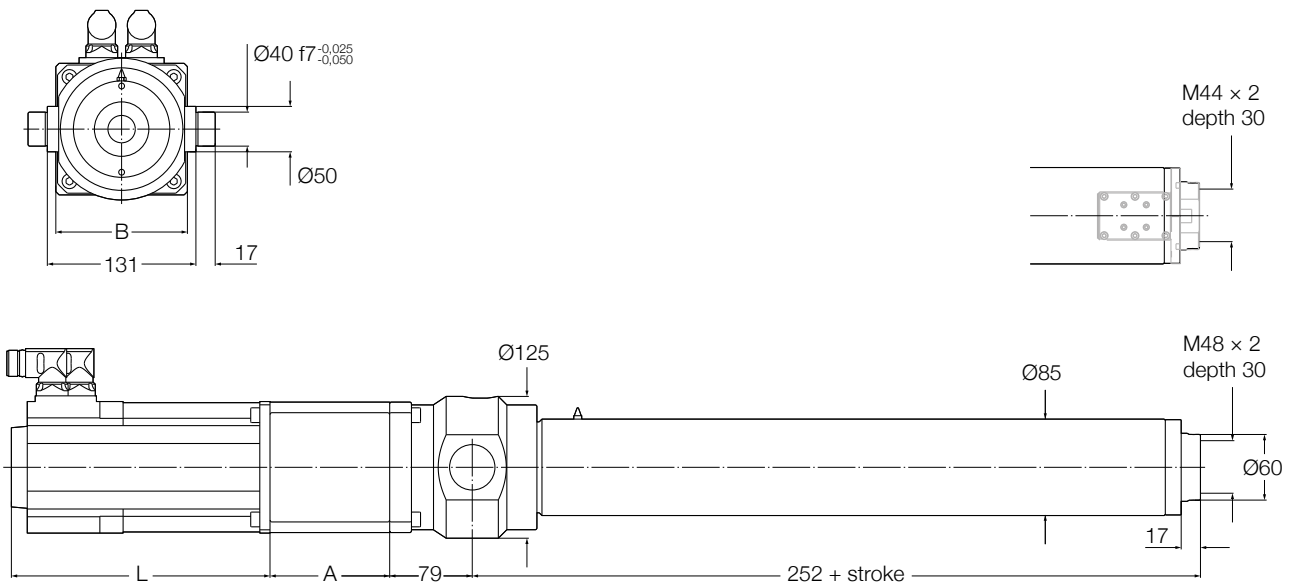

Reference	A	L	B	Added length for brake option	Added length for encoder option
-	mm				
L10LA1	111	188	116	20	49

SVSA-S-5001

With anti-rotation option

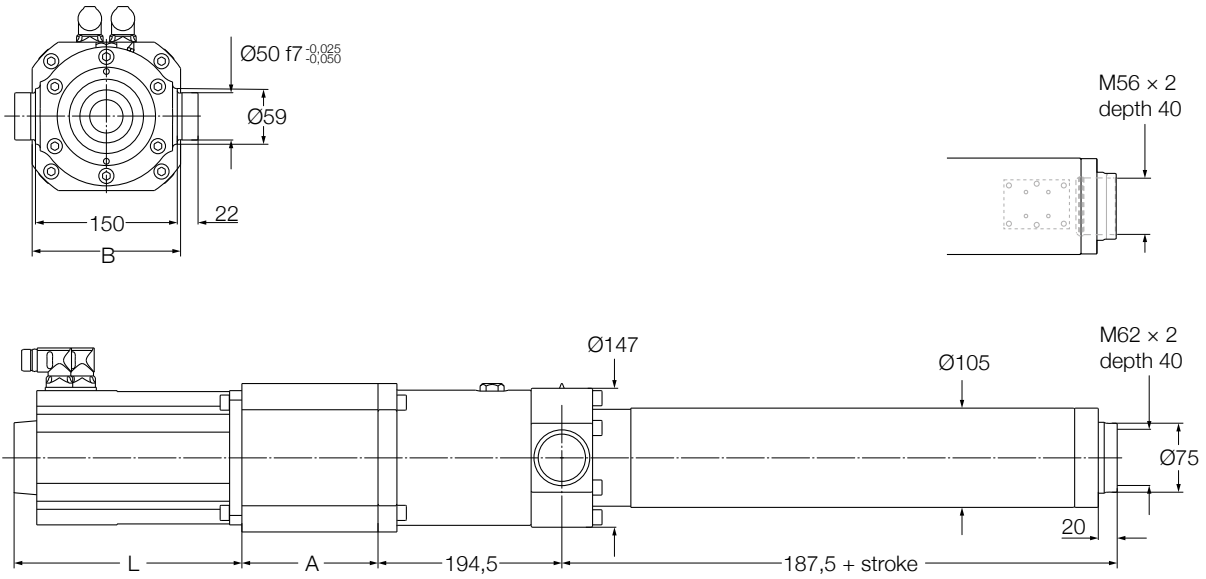

Reference	A	L	B	Added length for brake option	Added length for encoder option
-	mm				
L10LA5	134	268	185	20	49

Performance diagrams

Axial force [N]

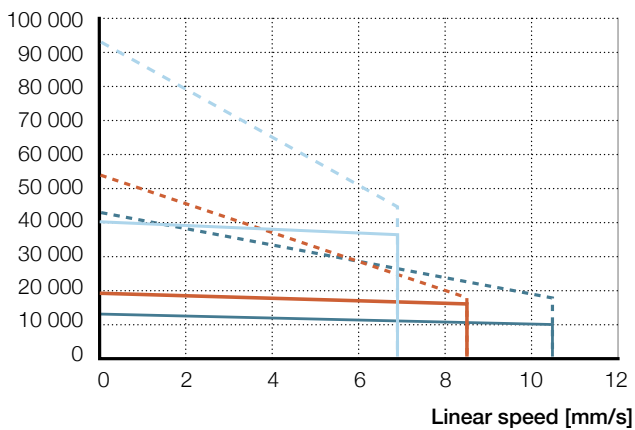

F_m [N]

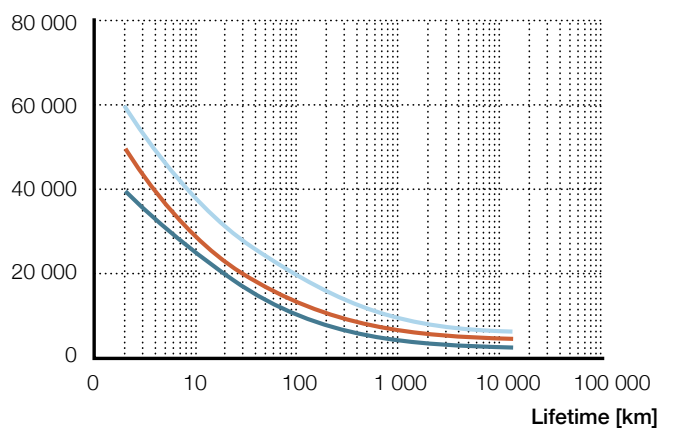

L10LC7	— F _{cont}	L10LA1	— F _{cont}	L10LA5	— F _{cont}
	- - - F _{peak}		- - - F _{peak}		- - - F _{peak}

— SVSA-3201	— SVSA-4001	— SVSA-5001
-------------	-------------	-------------

Ordering key

See page 42

SVSA-S-xx01

Electric cylinder servo motor,
parallel configuration



Technical data

Designation	Symbol	Unit	Servo motor and inline adapter		
			P10 LC7	P10 LA1	P10 LA5
Performance Data					
Continuous force @ zero speed	F_{c0}	kN	13,4	18,7	38,8
Continuous force @ max. speed	F_c	kN	9,9	16	34,9
Peak force @ zero speed	F_{p0}	kN	41,5	52,5	90,2
Peak force @ max. speed	F_p	kN	18,2	17,8	43,9
Dynamic load capacity	C	kN	64	79	174
Holding force (motorbrake option)	F_{Hold}	kN	64	79	174
Max. linear speed	v_{max}	mm/s	10,4	8,3	6,7
Max. acceleration	a_{max}	m/s ²	0,6	0,6	0,6
Duty cycle	D	%	100	100	100
Mechanical Data					
Screw type	–	–	Roller screw	Roller screw	Roller screw
Screw diameter	d_{screw}	mm	32	40	50
Screw lead	p_{screw}	mm	1	1	1
Lead accuracy	–	–	G5	G5	G5
Stroke ¹⁾	s	mm	100...600	100...800	100...900
Internal overstroke each side	s_0	mm	5	5	5
Backlash ³⁾	$s_{backlash}$	mm	0	0	0
Gear reduction	i		1	1	1
Inertia @ 0 mm stroke	J	10 ⁻⁴ kgm ²	7,70	17,25	47,65
Δ Inertia per 100 mm stroke	ΔJ	10 ⁻⁴ kgm ²	0,31	0,64	1,80
Inertia of optional brake	J_{brake}	10 ⁻⁴ kgm ²	1,07	1,07	1,07
Weight @ 0 mm stroke	m	kg	24	34,9	70,3
Δ weight per 100 mm stroke	Δm	kg	2,4	3,2	4,8
Weight of optional brake	m_{brake}	kg	0,8	0,9	0,9
Weight of anti-rotation @ 0 mm stroke	m_{arot0}	kg	2,6	-0,3	-0,3
Δ Weight of anti-rot. per 100 mm stroke	Δ m_{arot}	kg	0,3	0,2	0,4
Electrical Data					
Motor type	–	–	Servo	Servo	Servo
Nominal voltage	U	V AC	400	400	400
Nominal current	I	A	3	2,7	6,2
Peak current	I_{peak}	A	12,8	10	26,8
Nominal power	P	kW	1,220	1,120	2,760
Environment and Standards					
Ambient temperature	$T_{ambient}$	°C	0...+40	0...+40	0...+40
Degree of protection ²⁾	IP	–	54	54	54

¹⁾ By 100 mm steps

²⁾ With anti-rotation option IP44

³⁾ Backlash elimination up to stroke 600 mm. For longer strokes $s_{backlash} = 0,02$ mm

Dimensional drawing

SVSA-S-3201

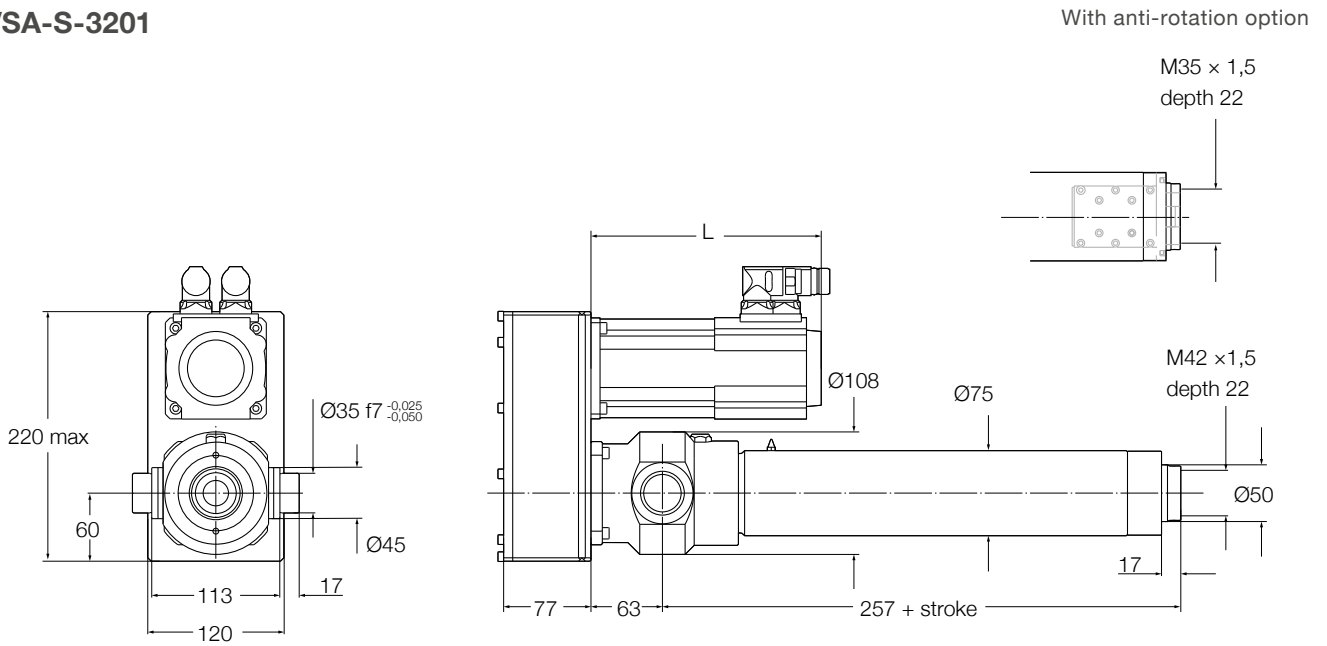

Reference	L	Added length for brake option	Added length for encoder option
-	mm		
P10LC7	203	20	51

SVSA-S-4001

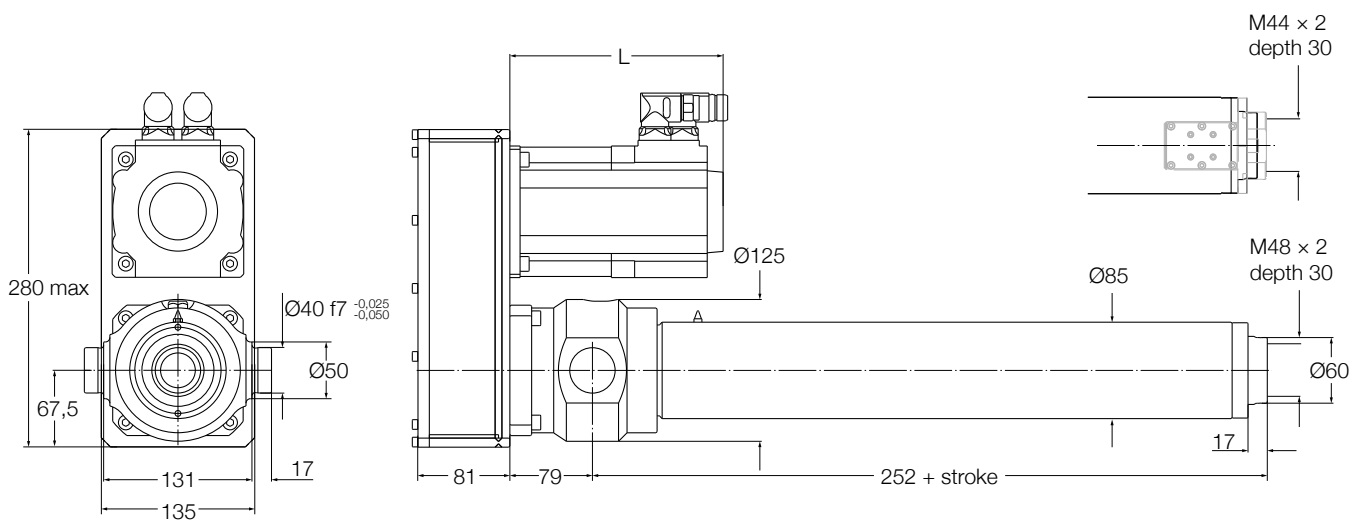

Reference	L	Added length for brake option	Added length for encoder option
-	mm		
P10LA1	188	20	49

SVSA-S-5001

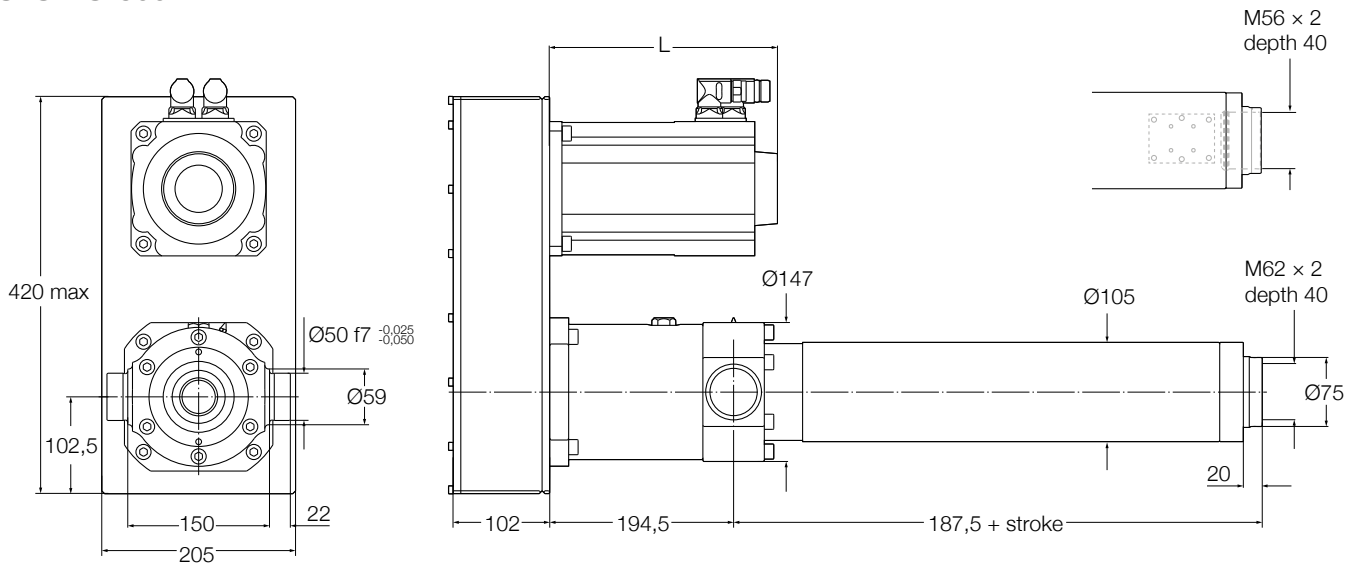

Reference	L mm	Added length for brake option	Added length for encoder option
-			
P10LA5	268	20	49

Performance diagrams

Axial force [N]

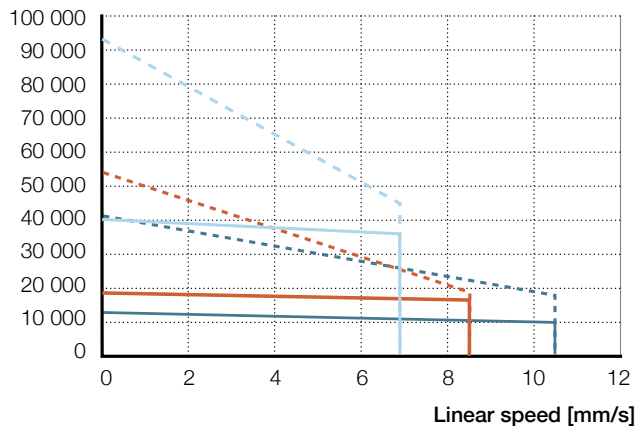

F_m [N]

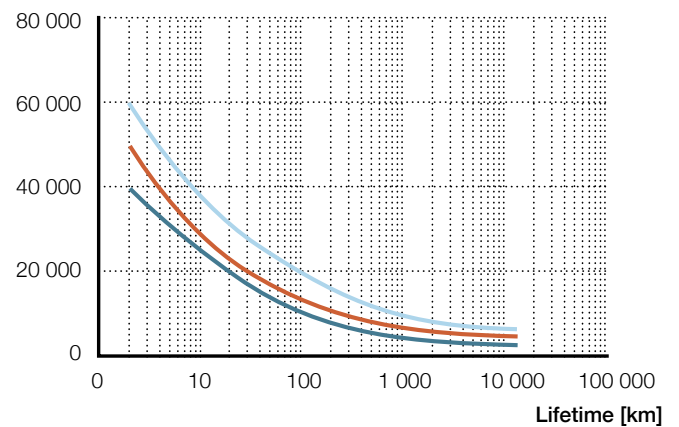

Ordering key

See page 42

Ordering key

Actuator with servo motors

S R S A - S - 4 8 1 0 - 0 2 0 0 - T R A F - L 0 1 0 L A 2 1 B Y A 1

Type

- R Planetary roller screw
- V Recirculating roller screw

Servomotor

Screw diameter

- 39 Planetary roller screw
- 48 Planetary roller screw
- 60 Planetary roller screw
- 75 Planetary roller screw
- 32 Recirculating roller screw
- 40 Recirculating roller screw
- 50 Recirculating roller screw

Screw lead

- 5 only for Planetary roller screw
- 10 only for Planetary roller screw
- 15 only for Planetary roller screw
- 20 only for Planetary roller screw diameter 48, 60, 75
- 1 only for Recirculating roller screw

Stroke

Rear attachment

- T Trunnions
- Z Non standard
- N No attachment

Front attachment

- R Rod end
- F Rod end with fork
- Z Non standard
- N No attachment (female thread)

Anti-rotation

- A Anti-rotation
- N No anti-rotation

Limit switches

- F 2 limit switches and 1 home switch
- S 2 limit switches only
- M 1 limit switch and 1 home switch
- L 1 limit switch only
- H 1 home switch only
- N No switch

S R S A - S - 4 8 1 0 - 0 2 0 0 - T R A F - L 0 1 0 L A 2 1 B Y A 1

Interface and gear ratio
See pages 5 and 6

Motor
See pages 5 and 6

Feedback
1 Resolver
2 Absolute encoder Hiperface
3 Absolute encoder Endat

EM brake
B Brake 24 V DC
N No brake

Motor drive
Y Drive included
N No drive

Drive fieldbus
A CanOpen
B DeviceNet
C EtherCAT
D Ethernet
E Powerlink MN/CN
F Powerlink CN
G Profibus
H Profinet
N No fieldbus

Power and signal cables
1 5 m
2 10 m
3 15 m
4 20 m
N No cable

Front attachment

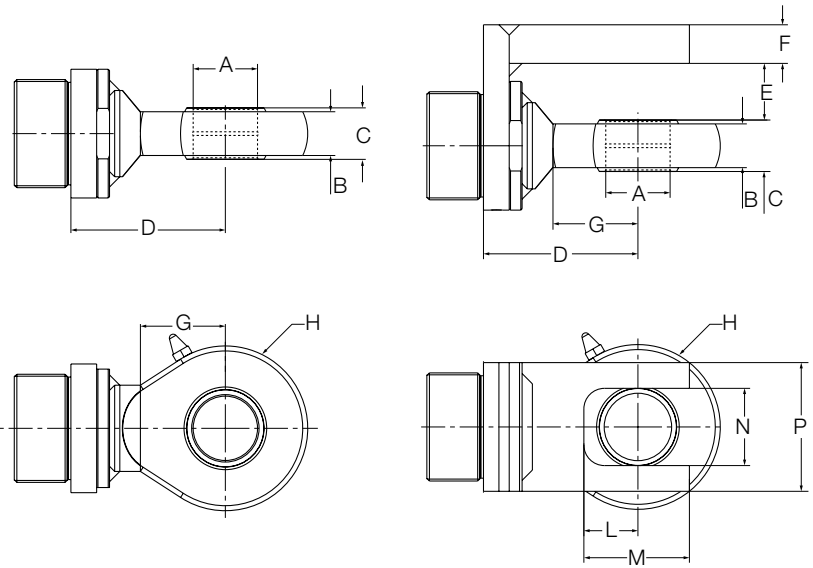

Type	F _{max} kN	A ¹⁾ mm	B	C	D	E	F	G	H	L	M	N	P
SVSA-x-32xx	25	Ø25	17	20 ⁰ _{-0,12}	60	22	15	33	Ø64	21	41	30 H9	50
SVSA-x-40xx	33	Ø30	19	22 ⁰ _{-0,12}	71	24	15	37,5	Ø73	23	45	35 H9	60
SRSA-x-39xx/SVSA-x-50xx	46	Ø40	23	28 ⁰ _{-0,12}	89	30	15	48	Ø92	29	58	45 H9	75
SRSA-x-48xx	77	Ø50	30	35 ⁰ _{-0,12}	110	38	15	59	Ø112	36	71	55 H9	95
SRSA-x-60xx	117	Ø60	38	44 ⁰ _{-0,12}	122	46	15	72,5	Ø135	43	83	65 H9	115
SRSA-x-75xx	192	Ø80	47	55 ⁰ _{-0,12}	168	50	15	98	Ø180	50	95	85 H9	140

¹⁾ Rod-end inner diameter A tolerance: m6.

Tolerance of axis which will be inserted in rod-end has to be in accordance with recommendations given in SKF spherical plain bearings and rod-end catalogue - publication PUB BU/P1 06116/1 EN.



ewellix.com

© Ewellix

All contents of this publication are the property of Ewellix, and may not be reproduced or given to third parties (even extracts) without permission. Although great care has been taken in the production of this catalog, Ewellix does not take any responsibility for damage or other loss resulting from omissions or typographical errors. The photo may differ slightly in appearance from the actual product. Due to continuous improvements being made in our products, the product's appearance and specifications are subject to change without notice.

PUB NUM IL-06011/2-EN-December 2021

Schaeffler and the Schaeffler logo are trademarks of the Schaeffler Group.